



CONTENT

Preservation

Cryo Freezer 07

-86°C ULT Freezer 11

- TwinCool ULT Freezer
- Frequency Conversion ULT Freezer
- Water-Cooled ULT Freezer
- Standard Low Energy ULT Freezer with LCD Touchscreen
- Standard Low Energy ULT Freezer with LED Display
- Under Counter ULT freezer
- Backup System
- Consumables for ULT Freezer

Biomedical Freezer 69

- 60°C Biomedical Freezer
- 40°C Biomedical Freezer
- 30°C Biomedical Freezer
- 25°C Biomedical Freezer

Spark Free Refrigerator/Freezer 85

- Spark Free Refrigerator
- Spark Free Freezer

Laboratory Refrigerator 95

Blood/Fluid Warming Cabinet 99

Pharmacy Refrigerator 101

- Combined Refrigerator and Freezer
- RFID Refrigerator
- Pharmacy Refrigerator with TEC
- Advanced Pharmacy Refrigerator with LCD Touchscreen
- Advanced Pharmacy Refrigerator with LED Display
- Standard Pharmacy Refrigerator
- Under-counter Pharmacy Refrigerator

Blood Bank Refrigerator 125

- Automated Blood Management Refrigerator
- Unattended Self-Service Blood Distribution Refrigerator
- Advanced Blood Bank Refrigerator with LCD Touchscreen
- Advanced Blood Bank Refrigerator with LED Display
- Standard Blood Bank Refrigerator
- Plasma Freezer

Transport Cooler 149

- Transport Cooler for Biological Products
- Transport Cooler for Infectious Materials
- Transport Cooler for Logistics

Vaccine Storage Solution

Smart Vaccine Refrigerator 159

Solar Direct Drive Series 166

- Solar Direct Drive Combined Refrigerator/Freezer
- Solar Direct Drive Vaccine Refrigerator
- Solar Direct Drive Vaccine Freezer
- Solar Direct Drive Blood Refrigerator

Ice-Lined Refrigerator 177

Vaccine & Icepack Freezer 183

Walk-in Cold/Freezer Room 185

30-Day Electronic Temperature Logger 189

Laboratory Equipment

Biological Safety Cabinet and Clean Bench 195

CO₂ Incubator 215

Liquid Nitrogen Storage Solutions 221

Vertical Automatic High-pressure Steam Sterilizer 257

Constant Climate Chamber 241

Health Care Products

Air Purification Sterilizer 249

Medical Infrared Thermometer 259

Infrared Thermometer 258

Blood Pressure Monitor 257

Portable Oxygen Concentrator 258

Models Line-up



-150°C Cryo freezer, developed by Haier Biomedical, provides a safe, convenient and economical alternative long term storage method for customers. By providing a storage environment about 20°C colder than the water recrystallization temperature, the freezer is suitable for storage of a varieties of biological samples such as viruses, erythrocytes, leukocytes, cutis, skeleton, sperms, oceanic products, special test materials and even electronic products for testing. It can be installed in institutions including blood banks, hospitals, epidemic prevention services, research institutes, and research laboratories.

Temperature Control

- Microprocessor control: Large LED display features a clear cabinet temperature display at an easy viewing angle and allows an adjustable range of -126°C to -150°C

Refrigeration System

- Optimized single stage refrigeration system
- Hermetically sealed system
- Environmentally safe refrigerants
- Permanently lubricated fan systems

Other Features

- Large LED display for easy viewing
- Ambient range of 10°C to 30°C
- LN₂ back up system compatible
- Remote monitoring
- Smart condenser fans for energy saving

Safety Control System

- Alarm system: User programmable high and low temperature alarm set points, power failure, sensor error, extreme voltage, hot condenser, and extremely high ambient
- Alarm types: audible buzzer and visible flashing
- Protection functions: Settable pass codes for control panel, start-up delay, voltage compensation system
- Properly grounded

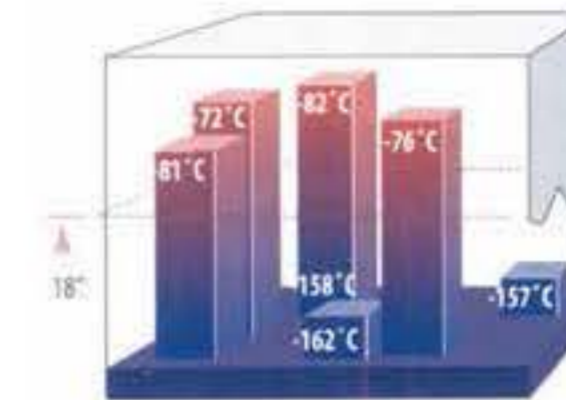

LN₂ Freezer System (-196 °C)

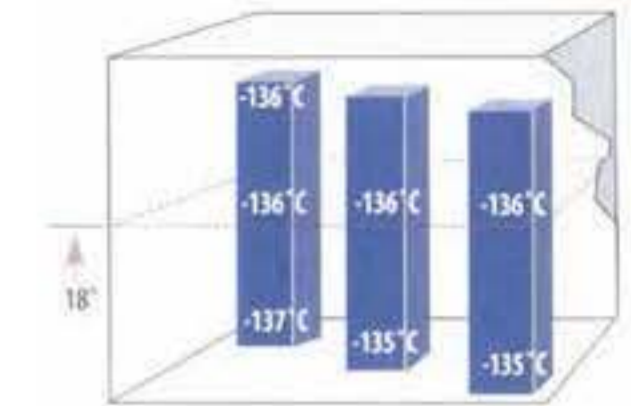

Cryo Freezer (-140°C)

Specifications

Model		DW-150W200	
Technical Data	Cabinet Type	Chest	
	Climate Class	N	
	Cooling Type	Direct Cooling	
	Defrost Mode	Manual	
	Refrigerant	HFC	
	Sound Level [dB(A)]	67	
	Performance	Cooling Performance [°C]	-150
Temperature Range [°C]		-126 ~ -150	
Control	Controller	Microprocessor	
	Display	LED	
Electrical Data	Power Supply [V/Hz]	380/50	
	Electrical Current [A]	11	
	Capacity [L/Cu.Ft]	200/7.1	
Dimensions	Net/Gross Weight [approx]	kg	315/385
		lbs	694.4/848.8
	Interior Dimension [W*D*H]	mm	667*462*650
		in	26.3*18.2*25.6
	Exterior Dimension [W*D*H]	mm	1670*850*1060
		in	65.7*33.5*41.7
	Packing Dimension [W*D*H]	mm	1810*940*1240
		in	71.3*37.0*48.8
Container load [20"/40"/40"H]	6/13/13		
Alarms	High/Low Temperature	Y	
	Hot Condenser	Y	
	Power Failure	Y	
	High/Low Voltage	Y	
	Sensor Error	Y	
	Low Battery	Y	
	High Ambient Temperature	Y	
	Door Ajar	N/A	
Accessories	Caster	Y	
	Foot	Y	
	Porthole	Y/1	
	Shelves/Innershelves	-/2	
	USB Interface	N/A	
	Remote Alarm [Dry contacts]	Y	
	SV Power Supply Port	N/A	
	Temperature Recorder	Optional	
	RS485 Port	Y	
	CO ₂ Backup System	N/A	
LN ₂ Backup System	Optional		
Others	Certification	N/A	

Product appearance and specifications are subject to change without notice.



**TwinCool
ULT Freezer**

Scope of Application

The TwinCool ULT freezer can be used for the storage and protection of valuable samples which require strict and continuous storage conditions such as viruses, pathogens, red blood cells, white blood cells, skin, bones, bacteria, semens and other biological products and special materials. Designed to operate even in the event of a compressor failure. Applicable to many storage requirements found within blood storage facilities, hospitals, disease control and prevention centres, scientific research institutions, biomedical engineering institutes and electronics and chemical industry.

Advanced Hardware System



Smart Full-size Touch Screen

10-inch touch screen with state-of-art user interface design, coupled with sample management system provides optimal user experience and better interaction

A Dual independent refrigeration systems for maximum sample safety

The dual refrigeration systems run independently and alternately, and both of them can reach up to -80°C through independent refrigeration. In case that failure occurs to one system, the sample storage safety can still be guaranteed.

B High speed refrigeration system for faster pull down and temperature recovery after door opening

It uses auto-cascade hydrocarbon refrigeration technology for faster pulldown; it takes just 180 minutes to reduce the temperature from ambient 25°C to -80°C. Typically, the temperature in the freezer can quickly recover to -75°C in 1 minute after the door being opened and closed so that the sample safety can be guaranteed.

C World-leading energy saving refrigeration technology

It adopts auto-cascade hydrocarbon refrigeration technology, three-layer energy saving and superinsulation design, which can increase the insulation efficiency by 30%, and reduce the energy by 50%. Power consumption is only 11kWh/day and the unit is certified by The National Quality Certification Center for energy saving and environmental protection.

IoT Software System



Simplified Sample Management Experience

Barcode scanner for simple, effortless and precise identification. Input and retrieve your samples with higher precision and efficiency



Wireless Monitoring Connectivity

Check the real-time operating status via mobile phones or palmtop, simple and reliable

Friendly Design



Safe and secure

Standard equipped with key lock, padlock and electromagnetic lock with optional fingerprint lock, providing multiple safeguards for sample safety



Low noise design, reducing the noise down to 53dB

Special noise-reduction design plus super silent compressor technology and energy-saving fan, considerably lowers noise level



Cloud data storage available

Store hundreds of millions of scientific research and sample information in the cloud server



Optimized insulation

Double foaming for both inner and outdoors and five-layer sealing design and optimized super-thick VIP thermal insulation technology, extends temperature holdover time during power failure and increases insulation efficiency by 20%

Specifications

Model	DW-86L578ST		DW-86L728ST
Technical Data	Cabinet Type	Upright	
	Climate Class	N	
	Cooling Type	Direct Cooling	
	Defrost Mode	Manual	
	Refrigerant	HC	
Performance	Sound Level (dB(A))	53	52
	Cooling Performance (°C)	-86	
	Temperature Range (°C)	-40--86	
Control	Controller	Microprocessor	
	LCD Touch Screen	LCD Touch Screen	
Electrical Data	Power Supply (V/Hz)	208~230/50	120/60
	Power (W)	1400	
	Electrical Current (A)	10	14
Dimensions	Capacity (L/Cu. Ft.)	578/20.4	
	Net/Gross Weight (approx)	kg	325/355
		lbs	716.5/782.6
	Interior Dimension (W*D*H)	mm	620*716*1310
		in	24.4*28.2*51.6
	Exterior Dimension (W*D*H)	mm	895*998*1980
in		35.2*39.3*78.0	
Packing Dimension (W*D*H)	mm	950*1055*2150	
	in	37.4*41.5*84.6	
Alarms	Container Load (20'/40'/40'H)	12/24/24	
	High/Low Temperature	Y	
	Hot Condenser	Y	
	Power Failure	Y	
	High/Low Voltage	Y	
	Sensor Error	Y	
	Low Battery	Y	
	High Ambient Temperature	Y	
	Door Ajar	Y	
	Caster	Y	
	Foot	Y	
	Porthole	Y/2	
Accessories	Shelves/Inner Doors	3/4	
	USB Interface	Y	
	Remote Alarm (Dry contacts)	Y	
	5V Power Supply Port	Y	
	Temperature Recorder	Optional	
	RS485 Port	Y	
Others	CO ₂ Backup System	Optional	
	LN ₂ Backup System	Optional	
	Certification	CE	ULENERGYSTAR

Product appearance and specifications are subject to change without notice

The TwinCool ultra-low temperature freezer of Haier Biomedical provides the highest level of protection for your valuable samples.



DW-86L578S

Safer by Design

Biomedical's ultra low temperature freezers with intelligent TwinCool technology are designed to provide optimal cabinet reliability, longevity, efficiency and sample protection. This super efficient technology also improves the energy efficiency of our third generation ULT freezers and leads the way in terms of product innovation.

Intelligent TwinCool Refrigeration System

Two independent refrigeration systems are designed to ensure optimal reliability, longevity and efficiency. Depending on the load demands and ambient conditions, one or both refrigeration systems will operate on demand, ensuring the samples are fully protected under the worst possible condition.



Maximum Sample Security

TwinCool system means extra insurance for temperature. Each independent refrigeration system can maintain -80°C separately.



Fast Cabinet Pull Down

Fast and efficient cabinet pulldown, it usually takes an average of three hours to reach -80°C at 25°C ambient. This means the temperature recovery after door opening is excellent ensuring the stored samples are not exposed to undesirable temperatures.



Maximum Energy Efficiency

The TwinCool ultra-low temperature system operates with 12 kWh/day.



World-leading Energy Saving Refrigeration Technology

The Haier hydrocarbon refrigeration technology uses less than 50% energy compared to traditional CFC refrigerants to reduce the operating cost. The refrigerants do not contain fluorine or chlorine giving it a GWP value of just three, which is better for the environment.



Reduced Running Costs

VIP thermal insulation system is designed to significantly reduce heat gain and operating cost.



Energy Saving Refrigeration
High efficiency cooling fans and compressors, combined with hydrocarbon refrigerants, ensure energy savings and long-term sample security



Pressure Equalisation Port
Heated Pressure Equalization Port allows users to re-open the main door quickly when entering. Adopts chromium plating, rust-proof



USB Interface
Enables users to download historical temperature data for compliance/auditing purposes



Multi-layer Sealing Structure
Triple gaskets provide a tight seal between the inner doors and outer door, reducing heat gain and retaining the temperature better in the event of a power failure



Improved Handle Design
Lockable handle safeguards your precious samples. A padlock can also be added for extra sample safety



Multi-level Alarms
Alarm functions include high, low temperature, sensor error, power failure, high ambient, clean filter and door ajar



DW-86L578S

DW-86L578S | TYPICAL PERFORMANCE CHARACTERISTICS AT 25°C AMBIENT

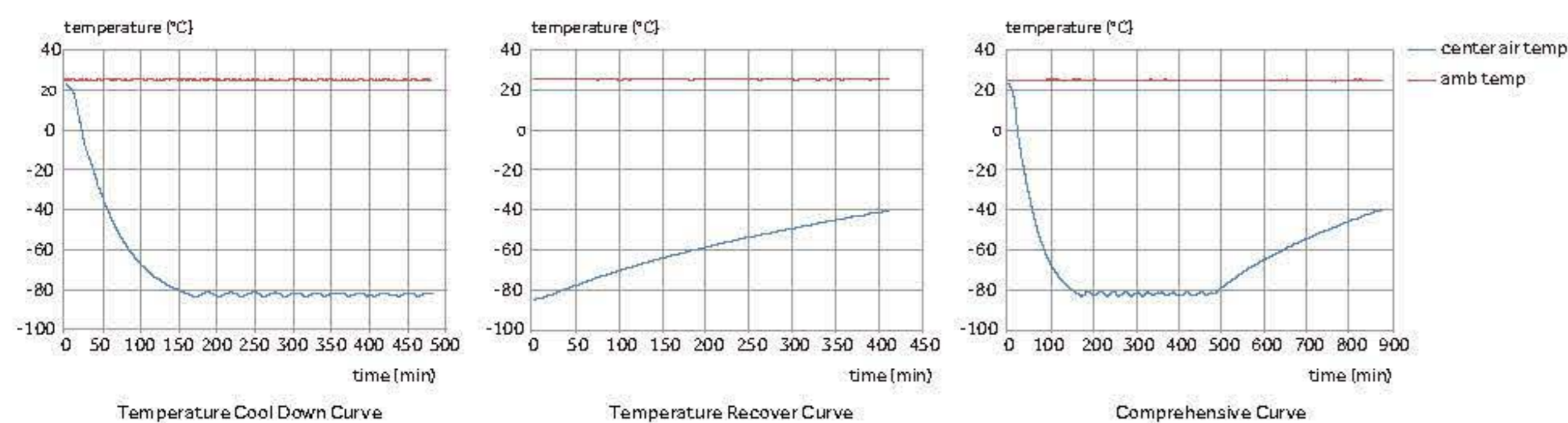

Specifications

Model		DW-86L578S	DW-86L728S	
Technical Data	Cabinet Type	Upright	Upright	
	Climate Class	N	N	
	Cooling Type	Direct Cooling	Direct Cooling	
	Defrost Mode	Manual	Manual	
	Refrigerant	HC	HC	
	Sound Level (dB(A))	53	50	
Performance	Cooling Performance (°C)	-86	-86	
	Temperature Range (°C)	-40~-86	-40~-86	
Control	Controller	Microprocessor	Microprocessor	
	Display	LED	LED	
Electrical Data	Power Supply (V/Hz)	208~230/50	208~230/50	
	Power (W)	1400	1400	
	Electrical Current (A)	10	10	
Dimensions	Capacity (L/Cu.Ft)	578/20.4	728/25.7	
	Net/Gross Weight (approx)	kg	325/355	350/385
		lbs	716.5/782.6	771.6/848.8
	Interior Dimension (W*D*H)	mm	620*716*1310	766*716*1310
		in	24.4*28.2*51.6	30.2*28.2*51.6
	Exterior Dimension (W*D*H)	mm	895*998*1980	1046*998*1980
		in	35.2*39.3*78.0	41.2*39.3*78.0
	Packing Dimension (W*D*H)	mm	950*1055*2150	1100*1105*2150
		in	37.4*41.5*84.6	43.3*43.5*84.6
	Container load (20'/40'/40'H)		12/24/24	10/20/20
Alarms	High/Low Temperature	Y	Y	
	Hot Condenser	Y	Y	
	Power Failure	Y	Y	
	High/Low Voltage	N/A	N/A	
	Sensor Error	Y	Y	
	Low Battery	Y	Y	
	High Ambient Temperature	Y	Y	
	Door Ajar	Y	Y	
	Accessories	Caster	Y	Y
		Foot	Y	Y
Porthole		Y/2	Y/2	
Shelves/Inner doors		3/4	3/4	
USB Interface		Y	Y	
Remote Alarm (Dry contacts)		Y	Y	
5V Power Supply Port		Y	Y	
Others	Temperature Recorder	Optional	Optional	
	RS485	Y	Y	
	CO ₂ Backup System	Optional	Optional	
	LN ₂ Backup System	Optional	Optional	
	Certification	CE	CE	

S suffix - Dual independent refrigeration systems
Product appearance and specifications are subject to change without notice



Smart Frequency
Conversion
ULT Freezer



Scope of Application

It can be used for products which require strict storage conditions such as viruses, pathogens, red blood cells, white blood cells, skin, bones, bacteria, semen, biological products, ocean products, electronic devices and special materials. Suitable for long term storage, meeting the cold storage requirements found in hospitals, disease control and prevention centres, scientific research institutions biomedical engineering institutes, agriculture/ fishery companies as well as the electronics and chemical industry.

Advanced Hardware System



Smart Full-size Touch Screen

10 inch capacitive touch screen, state-of-art UI design coupled with sample management system, optimal user experience

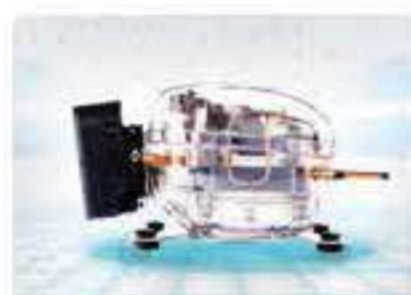

HC& Variable Frequency Drive Refrigeration System for Additional Energy Saving

Advanced innovative design delivers excellent energy saving performance. Energy consumption is down to a single digit.

IoT Software System



Simplified Sample Management Experience

Barcode scanner for simple, effortless and precise identification. Input and retrieve your samples with higher precision and efficiency



Wireless Monitoring Connectivity

Check the real-time operating status via mobile phones or palmtop, simple and reliable

A Quicker product access, identification and retrieval

Instead of a manual system, the one-gun, one-code and one-key operation plus touch screen synchronization means you can access and retrieve your samples within seconds

B 24-hour sample protection

Using Haier's app and IoT technology the unit can be monitored and can self-diagnose faults, ensuring you are always aware of your unit's status and able to make real-time and informed choices to protect your samples

C Super energy efficient with three environmentally friendly innovations

Ultra-low power consumption, down to less than 10KWh/day, ensuring a world leading energy saving performance

Friendly Design



Safe and secure

Standard equipped with key lock, padlock and electromagnetic lock with optional fingerprint lock, providing multiple safeguards for sample safety



Low noise design, reducing the noise down to 53dB

Special noise-reduction design plus super silent compressor technology and energy-saving fan, considerably lowers noise level



Cloud data storage available

Store hundreds of millions of scientific research and sample information in the cloud server



Optimized insulation

Double foaming for both inner and outdoors and five-layer sealing design and optimized super-thick VIP thermal insulation technology, extends temperature holdover time during power failure and increases insulation efficiency by 20%

Specifications

Model	DW-86L579BPT	DW-86L729BPT	DW-86L829BPT	DW-86L959BPT		
Technical Data	Cabinet Type	Upright	Upright	Upright	Upright	
	Climate Class	N	N	N	N	
	Cooling Type	Direct Cooling	Direct Cooling	Direct Cooling	Direct Cooling	
	Defrost Mode	Manual	Manual	Manual	Manual	
	Refrigerant	HC	HC	HC	HC	
	Sound Level [dB(A)]	43.5	43.5	43.5	47	
Performance	Cooling Performance [°C]	-86	-86	-86	-86	
	Temperature Range [°C]	-40~-86	-40~-86	-40~-86	-40~-86	
Control	Controller	Microprocessor	Microprocessor	Microprocessor	Microprocessor	
	LCD Touch Screen	LCD Touch Screen	LCD Touch Screen	LCD Touch Screen	LCD Touch Screen	
Electrical Data	Power Supply [V/Hz]	100~230/50/60	100~230/50/60	208~230/50/60	208~230/50/60	
	Power [W]	1100	1100	1100	1300	
	Electrical Current [A]	6	6	6	7	
Dimensions	Capacity [L/Cu.Ft.]	579/20.4	729/25.7	829/29.2	959/33.9	
	Net/Gross Weight [approx]	kg	325/355	350/385	380/415	450/485
		lbs	716.5/782.6	771.6/848.8	837.7/914.9	992.1/1069.2
	Interior Dimension [W*D*H]	mm	620*716*1310	766*716*1310	870*716*1310	1016*716*1310
		in	24.4*28.2*51.6	30.2*28.2*51.6	34.3*28.2*51.6	40.0*28.2*51.6
	Exterior Dimension [W*D*H]	mm	895*998*1980	1046*998*1980	1145*998*1980	1296*998*1980
		in	35.2*39.3*78.0	41.2*39.3*78.0	45.1*39.3*78.0	51.0*39.3*78.0
Packing Dimension [W*D*H]	mm	950*1055*2150	1100*1105*2150	1190*1045*2150	1365*1105*2150	
	in	37.4*41.5*84.6	43.3*43.5*84.6	46.9*41.1*84.6	53.7*43.5*84.6	
Container load [20'/40'/40'H]		12/24/24	10/20/20	8/20/20	8/16/16	
Alarms	High/Low Temperature	Y	Y	Y	Y	
	Hot Condenser	Y	Y	Y	Y	
	Power Failure	Y	Y	Y	Y	
	High/Low Voltage	Y	Y	Y	Y	
	Sensor Error	Y	Y	Y	Y	
	Low Battery	Y	Y	Y	Y	
	High Ambient Temperature	Y	Y	Y	Y	
	Door Ajar	Y	Y	Y	Y	
	Caster	Y	Y	Y	Y	
	Foot	Y	Y	Y	Y	
Accessories	Porthole	Y/2	Y/2	Y/2	Y/2	
	Shelves/Inner Doors	3/4	3/4	3/4	3/4	
	USB Interface	Y	Y	Y	Y	
	Remote Alarm [Dry contacts]	Y	Y	Y	Y	
	SV Power Supply Port	Y	Y	Y	Y	
	Temperature Recorder	Optional	Optional	Optional	Optional	
	RS485 Port	Y	Y	Y	Y	
	CO ₂ Backup System	Optional	Optional	Optional	Optional	
	LN ₂ Backup System	Optional	Optional	Optional	Optional	
	Others	Certification	CE,UL,ENERGY STAR	CE,UL,ENERGY STAR	CE,UL,ENERGY STAR	CE,UL,ENERGY STAR

BP suffix - Variable frequency inverter compressor

T suffix - Advanced with touchscreen

Product appearance and specifications are subject to change without notice

bitstrong Biomedical's SmartFrequency technology manages the compressor speeds on demand. The ultra-low temperature freezers can thus achieve the world-leading energy efficiency in ultra-low temperature.



DW-86L829BP

Smarter by Design

The SmartFrequency Conversion range of ultra low temperature freezers have been designed and developed at the bitstrong Biomedical R&D Institute. They are certified by one of the world's leading energy conservation and environmental protection organisations.



Intelligent frequency Conversion technology

Two variable speed compressors are controlled for optimal freezer performance. Low energy consumption is achieved.



Maximum energy efficiency

Our SmartFrequency Technology, coupled with our environmentally safe and friendly hydrocarbon refrigeration system, allows the Haier freezers to operate at a low level of energy of 8.2 kWh/day.



Precise temperature control

The innovative control algorithm balances the effects of temperature loss with the unique frequency conversion refrigeration system, ensuring the cabinet temperature stability of $\pm 3^{\circ}\text{C}$.



Frequency conversion Adaptive technology

Variable speed compressors in Haier Biomedical freezers are operated to produce the capacity that matches the demand of the load. The control system automatically tunes the speed of the compressors to optimize the operation.



World-leading energy saving Refrigeration technology

Our hydrocarbon refrigeration technology can save energy by 50%, significantly reducing operator's cost. The refrigerants do not contain fluoride and chloride. The global warming potential is extremely low at 3. Thus they are very friendly to the environment.



Minimal sound level output

Adaptive control technology controls the fans and compressors to reduce the sound level to 43.5 dB(A).



Energy Saving Refrigeration

High efficiency cooling fans and compressors, combined with hydrocarbon refrigerants, ensure energy savings and long-term sample security



Pressure Equalisation Port

Heated port with spring assisted mechanism to prevent icing on the vent allows users to reopen the main door soon after entering. Adopts chromium plating, rust-proof



USB Interface

Enables users to download historical temperature data for compliance/auditing purposes



Multilayered Sealing Structure

Triple layer of gaskets split between main and inner doors decreases heat loss and guarantee excellent warm up times in the event of a power failure



Improved Handle Design

Lockable handle with unique key prevents other Haier freezer owner's access to your precious samples, also comes with space for a padlock for that extra security



Multilevel Alarms

Alarming functions that include high and low temperature, sensor error, power failure, high ambient, clean filter and door ajar



DW-86L829BP

DW-86L829BP | TYPICAL PERFORMANCE CHARACTERISTICS AT 25°C AMBIENT

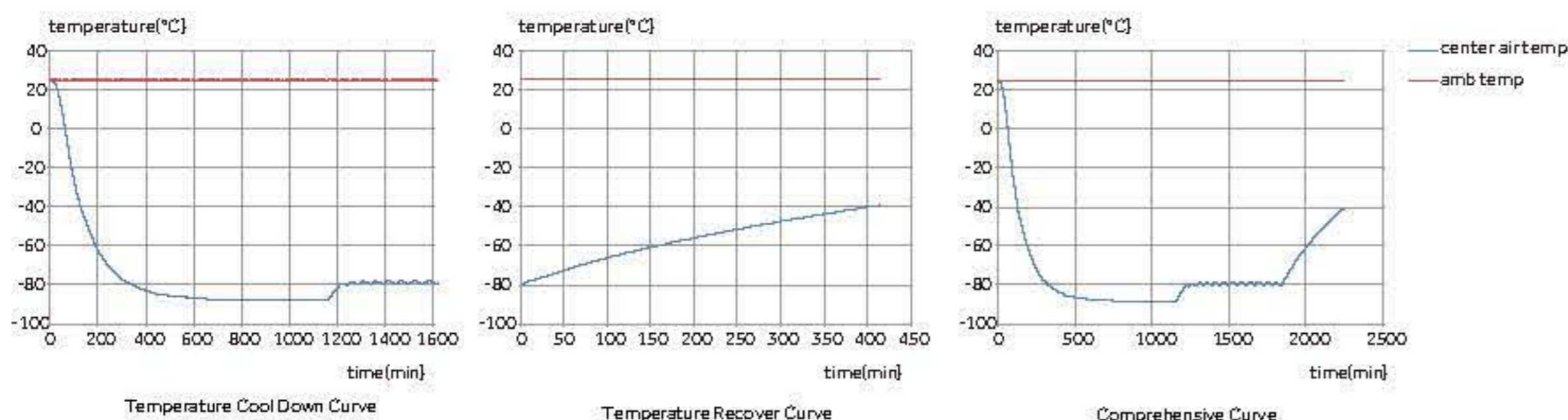

Specifications

Model	DW-86L579BP	DW-86L729BP	DW-86L829BP	DW-86L959BP		
Technical Data	Cabinet Type	Upright	Upright	Upright	Upright	
	Climate Class	N	N	N	N	
	Cooling Type	Direct Cooling	Direct Cooling	Direct Cooling	Direct Cooling	
	Defrost Mode	Manual	Manual	Manual	Manual	
	Refrigerant	HC	HC	HC	HC	
Performance	Sound Level (dB(A))	43.5	43.5	43.5	47	
	Cooling Performance (°C)	-86	-86	-86	-86	
Control	Temp Range (°C)	-40~-86	-40~-86	-40~-86	-40~-86	
	Controller	Microprocessor	Microprocessor	Microprocessor	Microprocessor	
Electrical Data	Display	LED	LED	LED	LED	
	Power Supply (V/Hz)	100~230/50/60	100~230/50/60	208~230/50/60	208~230/50/60	
Dimensions	Power (W)	1100	1100	1100	1300	
	Electrical Current (A)	6	6	6	7	
Dimensions	Capacity (L/Cu.Ft)	579/20.4	729/25.7	829/29.2	959/33.9	
	Net/Gross Weight (approx)	kg	325/355	350/385	380/415	450/485
		lbs	716.5/782.6	771.6/848.8	837.7/914.9	992.1/1069.2
	Interior Dimensions (W*D*H)	mm	620*716*1310	766*716*1310	870*716*1310	1016*716*1310
		in	24.4*28.2*51.6	30.2*28.2*51.6	34.3*28.2*51.6	40.0*28.2*51.6
	Exterior Dimensions (W*D*H)	mm	895*998*1980	1046*998*1980	1145*998*1980	1296*998*1980
in		35.2*39.3*78.0	41.2*39.3*78.0	45.1*39.3*78.0	51.0*39.3*78.0	
Packing Dimension (W*D*H)	mm	950*1055*2150	1100*1105*2150	1190*1045*2150	1365*1105*2150	
	in	37.4*41.5*84.6	43.3*43.5*84.6	46.9*41.1*84.6	53.7*43.5*84.6	
Alarms	Container Load (20'/40'/40'H)	12/24/24	10/20/20	8/20/20	8/16/16	
	Remote Alarm (Dry contacts)	Y	Y	Y	Y	
	High/Low Temp	Y	Y	Y	Y	
	Hot Condenser	Y	Y	Y	Y	
	Power Failure	Y	Y	Y	Y	
	Sensor Error	Y	Y	Y	Y	
	Low Battery	Y	Y	Y	Y	
	High Ambient Temp	Y	Y	Y	Y	
	Door Ajar	Y	Y	Y	Y	
Accessories	Caster	Y	Y	Y	Y	
	Foot	Y	Y	Y	Y	
	Porthole	Y/2	Y/2	Y/2	Y/2	
	Shelves/ Inner Doors	3/4	3/4	3/4	3/4	
	USB Interface	Y	Y	Y	Y	
	5V Power Supply Port	Y	Y	Y	Y	
	Temp Recorder	Optional	Optional	Optional	Optional	
	RS485 Port	Y	Y	Y	Y	
	CO ₂ Backup System	Optional	Optional	Optional	Optional	
	LN ₂ Backup System	Optional	Optional	Optional	Optional	
Other	Certification	CE,UL,ENERGY STAR	CE,UL,ENERGY STAR	CE,UL,ENERGY STAR	CE,UL,ENERGY STAR	

BP suffix - Variable frequency inverter compressor
Product appearance and specifications are subject to change without notice

bitstrong water-cooled ULT freezers are designed to meet strict requirements for storage of plasma, biological materials, vaccines, reagents, specimens, and other valuable samples. They are ideal for installations in hospitals, clinics, blood banks and medical research facilities where freezer heat must be removed by cooling water.



Advantages

- Intelligent frequency conversion technology
- Advanced control Touchscreen
- Higher efficiency to yield more energy savings of up to 20%
- Approximately 90% of the compressor heat generated during operation is removed by the cooling water, thus posing little impact to a laboratory's ambient.
- Use less air-conditioning power for a comfortable laboratory condition
- Advanced control
- Low sound level
- Smart coolant control
- High quality industry grade hermetically sealed compressors
- Pressure protection system due to lack of water flow



Specifications

Model		DW-86L828W	DW-86L959W	
Technical Data	Cabinet Type	Upright	Upright	
	Climate Class	N	N	
	Cooling Type	Direct cooling	Direct cooling	
	Defrost Mode	Manual	Manual	
	Refrigerant	HC	HC	
	Sound Level [dB(A)]	43.5	47	
Performance	Cooling Performance [°C]	-86	-86	
	Temperature Range [°C]	-40~-86	-40~-86	
Control	Controller	Microprocessor	Microprocessor	
	LCD Touch Screen	LCD Touch Screen	LCD Touch Screen	
Electrical Data	Power Supply [V/Hz]	208 ~ 230/50/60	208 ~ 230/50/60	
	Power [W]	1100	1300	
	Electrical Current [A]	6	7	
	Capacity [L/Cu.Ft]	828/29.2	959/33.9	
Dimensions	Net/Gross Weight [approx]	kg	380/415	450/485
		lbs	837.7/914.9	992.1/1069.2
	Interior Dimension [W*D*H]	mm	870*716*1310	1016*716*1310
		in	34.3*28.2*51.6	40.0*28.2*51.6
	Exterior Dimension [W*D*H]	mm	1145*998*1980	1296*998*1980
		in	45.1*39.3*78.0	51.0*39.3*78.0
	Packing Dimension [W*D*H]	mm	1190*1045*2150	1365*1105*2150
		in	46.9*41.1*84.6	53.7*43.5*84.6
Container Load [20'/40'/40'H]		8/20/20	8/16/16	
Alarms	High/Low Temperature	Y	Y	
	Hot Condenser	Y	Y	
	Power Failure	Y	Y	
	High/Low Voltage	Y	Y	
	Sensor Error	Y	Y	
	Low Battery	Y	Y	
	High Ambient Temperature	Y	Y	
	Door Ajar	Y	Y	
	Caster	Y	Y	
	Foot	Y	Y	
Accessories	Porthole	Y/2	Y/2	
	Shelves/Inner doors	3/4	3/4	
	USB Interface	Y	Y	
	Remote Alarm [Dry contacts]	Y	Y	
	SV Power Supply Port	Y	Y	
	Temperature Recorder	Optional	Optional	
	Rs485 Port	Y	Y	
	CO ₂ Backup System	Optional	Optional	
	LN ₂ Backup System	Optional	Optional	
	Others	Certification	CE	CE

Product appearance and specifications are subject to change without notice

Haier Biomedical Salvum brand of ULT freezers has been designed to deliver energy savings and reduced carbon footprint. This range uses environmentally safe hydrocarbon refrigerants and high efficiency fan motors to maximize the cooling ability of the system and reduce energy consumption. While providing sample safety, the freezer design makes energy savings possible for laboratories.



DW-86L829



DW-86LS79



Large Intelligent LCD Screen Visual Management

10-inch high-performance LCD capacitive screen, sensitive touch operation; intuitive display of inside temperature, ambient temperature, input voltage and other data and temperature curves.

Inventory Management System

The single version of the inventory management allows users who do not have a racking system within the freezer to easily record item locations, entry and exit records.

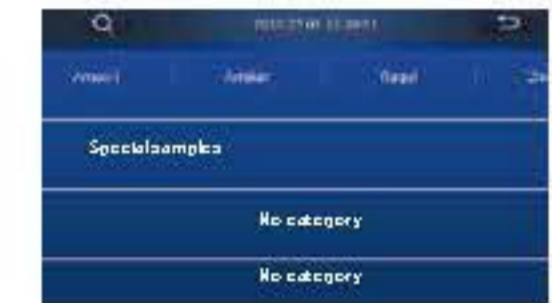

Single version (standard)



Professional version (optional)

In instances where customers use racking systems, the optional professional version of the inventory management is available. Freezer racks, boxes, and vials can easily record item locations and entry and exit records, facilitate item inventory and statistics, realize multi-screen interaction and reduce errors through secondary verification.

The freezer comes with the single version as standard.

Equipped with Multiple Interfaces

- Standard USB interface, capable of storing data for 10 years
- Standard remote alarm terminal RS485 port



Multiple Options for Safe Management and Control Systems

Standard password lock, optional fingerprint module, punch card module, face recognition, realizing safe and secure multi-user management.

Optional IoT System Realizes Real-time Monitoring

The IoT APP can monitor the operating status of the equipment anytime and anywhere. Equipped with multiple alarm functions and able to self-diagnose system faults to ensure sample safety. (Contact your local area representative to check local availability.)



Safe and Secure with Multiple Alarms

Multiple alarm functions include high temperature alarm, low temperature alarm, sensor failure alarm, power failure alarm, low battery alarm, door ajar alarm and high ambient temperature alarm.



Precise Temperature Control Ensures Safe Storage

Adjustable temperature set-point between -40°C - -86°C and the ability to monitor temperature curves in real time, equipped with sophisticated temperature safety alarm system to ensure product safety.

Ergonomic Design



Narrow Door Design

The freezer can pass through an 750mm wide door when the door is open.



New Handle Design

Adopting exclusive slide design, easy to open and close the door.



Pressure Equalization Port

Equipped with pressure equalization port, realize easy opening. Adopts chromium plating, rust-proof.



Porthole

Two portholes as standard, allows for independent testing of cabinet temperature.



Filter Design

Tool-free removable filter design, easy and quick to clean the filter.



Detachable Inner Door Design

Tool-free detachable inner door, realizing easy and quick defrost.

Specifications

Model	DW-86L419	DW-86L579	DW-86L729	DW-86L829		
Technical Data	Cabinet Type	Upright	Upright	Upright	Upright	
	Climate Class	N	N	N	N	
	Cooling Type	Direct cooling	Direct cooling	Direct cooling	Direct cooling	
	Defrost Mode	Manual	Manual	Manual	Manual	
	Refrigerant	HC	HC	HC	HC	
	Sound Level [dB(A)]	47	47	52	52	
Performance	Cooling Performance [°C]	-86	-86	-86	-86	
	Temp Range [°C]	-40~-86	-40~-86	-40~-86	-40~-86	
Control	Controller	Microprocessor	Microprocessor	Microprocessor	Microprocessor	
	Display	LCD	LCD	LCD	LCD	
Electrical Data	Power Supply [V/Hz]	220~240/50	220~240/50	220~240/50	220~240/50	
	Power [W]	800	1000	1700	1700	
	Electrical Current [A]	5	5.5	9	10	
Dimensions	Capacity [L/Cu.Ft]	419/14.8	579/20.45	729/25.75	829/29.3	
	Net/Gross Weight [approx]	kg	255/286	300/330	350/385	380/410
		lbs	562.2/630.5	661.4/727.5	771.6/848.8	837.7/903.9
	Interior Dimensions [W*D*H]	mm	465*716*1310	620*716*1310	766*716*1310	870*716*1310
		in	18.3*28.2*51.6	24.4*28.2*51.6	30.2*28.2*51.6	34.3*28.2*51.6
	Exterior Dimensions [W*D*H]	mm	830*980*1980	903*980*1960	1049*980*1980	1153*980*1980
		in	32.7*38.6*78.0	35.6*38.6*77.2	41.3*38.6*78.0	45.4*38.6*78.0
	Packing Dimension [W*D*H]	mm	897*1078*2135	950*1055*2130	1100*1105*2150	1190*1045*2150
		in	35.3*42.4*84.1	37.4*41.5*83.9	43.3*43.5*84.6	46.9*41.1*84.6
	Container Load [20'/40'/40'H]		12/26/26	12/24/24	10/20/20	10/20/20
Alarms	Remote Alarm [Dry contacts]	Y	Y	Y	Y	
	High/Low Temp	Y	Y	Y	Y	
	Hot Condenser	Y	Y	Y	Y	
	Power Failure	Y	Y	Y	Y	
	Sensor Error	Y	Y	Y	Y	
	Low Battery	Y	Y	Y	Y	
	High Ambient Temp	Y	Y	Y	Y	
	Door Ajar	Y	Y	Y	Y	
Accessories	Caster	Y	Y	Y	Y	
	Foot	Y	Y	Y	Y	
	Porthole	Y/2	Y/2	Y/2	Y/2	
	Shelves/ Inner Doors	3/2	3/4	3/4	3/4	
	USB Interface	Y	Y	Y	Y	
	Remote Alarm	Y	Y	Y	Y	
	5V Power Supply Port	Y	Y	Y	Y	
	Temp Recorder	Optional	Optional	Optional	Optional	
	RS485 Port	Standard	Standard	Standard	Standard	
	CO ₂ Backup System	Optional	Optional	Optional	Optional	
LN ₂ Backup System	Optional	Optional	Optional	Optional		
Other	Certification	CE	CE	CE	CE	

Product appearance and specifications are subject to change without notice.

This product line is designed and manufactured for long term storage of various biological products, including viruses, germs, erythrocytes and leucocytes. Applications can be found in blood banks, hospitals, epidemic prevention services, research institutes, biological engineering institutes, laboratories in electronic and chemical plants.



Advantages

- World leading energy-efficient
- Hydrocarbon refrigeration system
- Slim cabinet design
- Reliable sample protection
- Malfunction alarms
- Excellent insulation performance

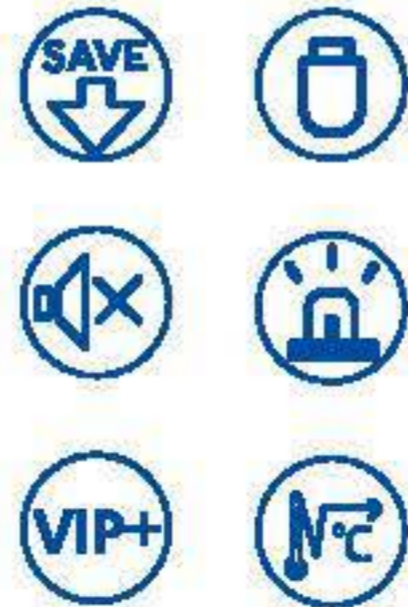

Insulation and System Design

- Special V-I-P (Vacuum Insulation Panel) insulation system reduces the heat gain by 25%
- High efficiency HC refrigeration system improves the overall efficiency by 45%
- Four individual insulated inner doors reduce the cold air loss to the minimum
- Heated Pressure Equalization Port makes re-accessing the unit fast
- About 50 dba sound level

Safe and Reliable Storage

- Superior temperature uniformity
- Dependable fans, compressors and other system related components

Alarms (Visual and Audible)

- Adjustable High/Low temperature alarm
- Sensor error
- Low battery
- Door ajar
- Power failure
- Hot condenser
- High ambient
- Remote alarm contact

Extended Warm up Time During Power Failure

- Warm up time measures the time taken for temperature to rise up (from -80°C to -50°C) at 25°C ambient when the power is interrupted.
- Haier has the longest warm up time when compared with other major brands in the market.

TYPICAL PERFORMANCE CHARACTERISTICS AT 25°C AMBIENT

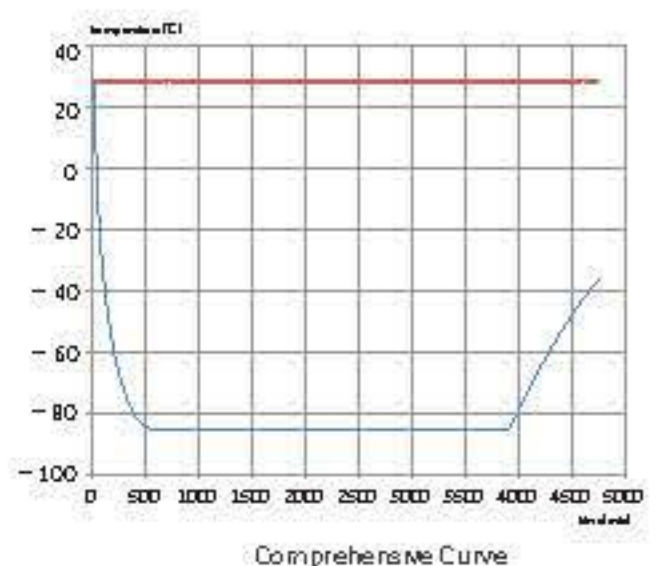
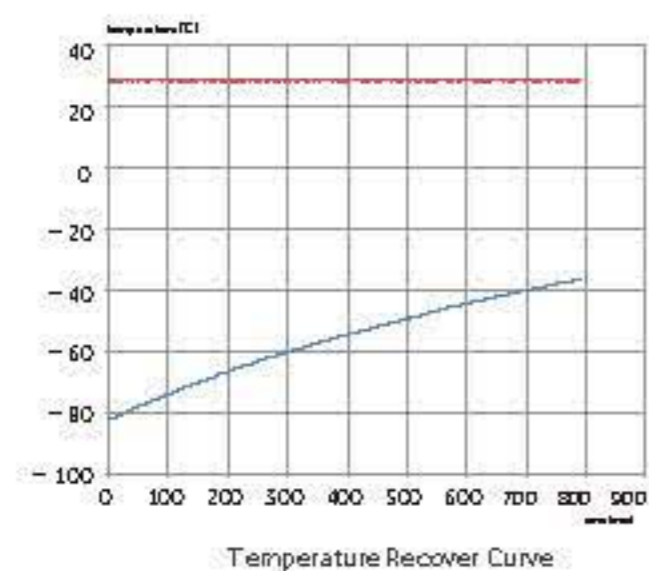
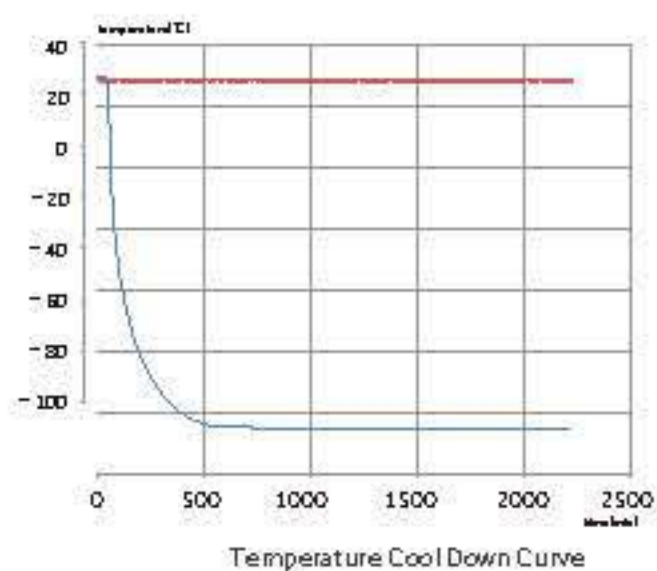

— 3rd centre
— ambient temp



4 Individual Removable Foam Inner Doors

- 4 individual inner doors can be opened independently to minimize frost buildup inside the chamber.
- Unique door seal design for the minimum loss of cold temperature during a door opening.
- Compatibility with existing racking system from competitors.
- Stainless steel handle to ensure proper strength for door latching.
- Some interior door handles have been upgraded to stainless steel for more comfortable door opening experience.



Excellent Doors Seals

- Total of five gaskets to safeguard the freezer temperature, including four seals for the exterior door, one for each inner door.



- Optimized sideway design, easier to open and close the door.



Pressure Equalization Port

- Heated port with spring-assisted mechanism to prevent icing on the vent.
- Allows re-accessing the freezer after initial door opening.
- Adopts chromium plating, rust-proof.



Circular-chart Recorder (Optional)

- Front-mounted.
- For independent temperature monitoring.



DW-86L728J

High Efficiency Refrigeration Components

- Hermetically sealed industrial grade compressors for ultra-low refrigeration application.
- Low sound level.
- High efficient oil separator.
- Unique hydrocarbon refrigeration system to provide maximum efficiency in extreme conditions.



Two port holes for ease of temperature monitoring

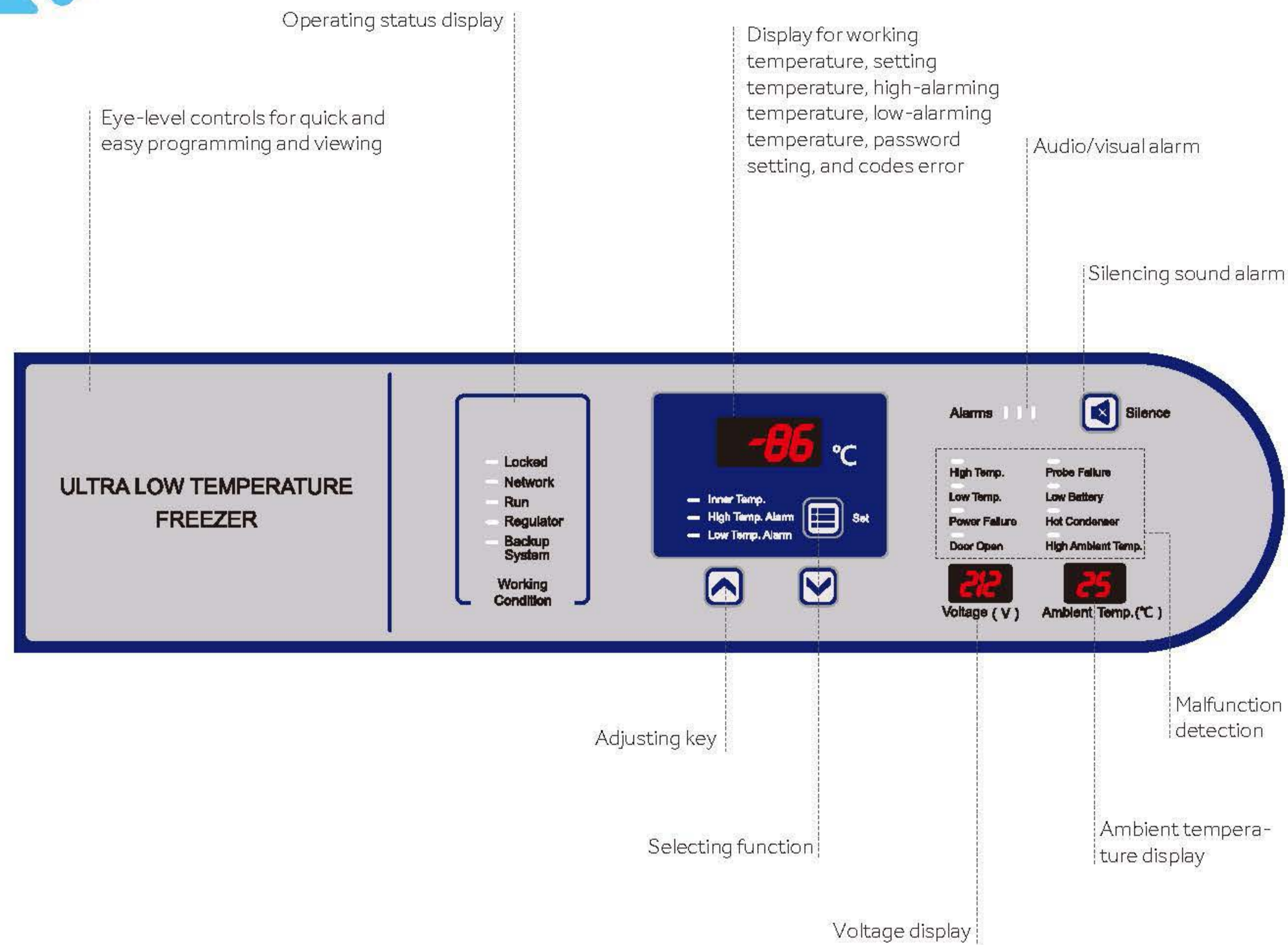

Specifications

Alarm	Alarm Triggering Condition
High Temperature	Temperature reaches the warm alarm limit
Low Temperature	Temperature reaches the low alarm limit
Power Failure	Equipment loses power
Door Ajar	Door opening time exceeds set time, settable between 0 and 20 minutes
Sensor Error	E0.Ambient sensor fails E1.Condenser sensor fails E2.Main cabinet temperature control sensor fails E3.Heat exchanger sensor fails E4.Heat exchanger temperature fails
Low Battery	Battery capacity runs low or battery switch is not turned on
Hot Condenser	1. Condensers filter element is clogged 2. Ambient temperature is too high
High Ambient Temperature	Ambient temperature exceeds 32°C



Field proven reliability

- Unique insulated inner door design for four separate storage compartments to minimize frost buildup inside the chamber
- Specialized control system design for a well-balanced operation of cascade refrigeration system
- Positive field proven reliability record

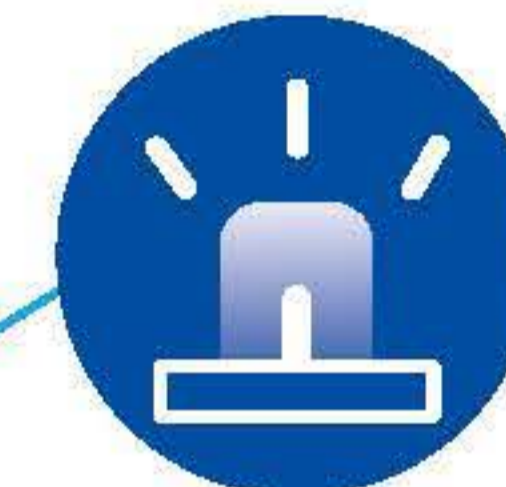

Safety

- Malfunction alarms including high and low temperature, power failure, sensor error, clean -filter, and extremely high ambient
- Capable of producing two types of alarm outputs: audible buzzer and visible flashing light
- Multiple built-in system protection features including user-settable protection code for controls, user settable delay to start, voltage compensation system, and protection against extreme high voltages
- Door open feature standard and USB port for temperature data downloading standard on upright models
- Remote alarm contacts



Installation & Application

- Wide range operating voltage system from 185V to 260 V designed to allow units installed in areas with poor voltage condition
- Suitable for 10°C to 32°C ambient temperature
- Input voltage and ambient temperature shown simultaneously for ease of monitoring environmental conditions
- Robust door latch designed for secure door closing
- Compact casters for ease of maneuvering



Low sound level

- Specialized refrigeration system design using whisper quiet fan and compressors
- Freezer chassis designed to absorb vibration and sound



Energy saving







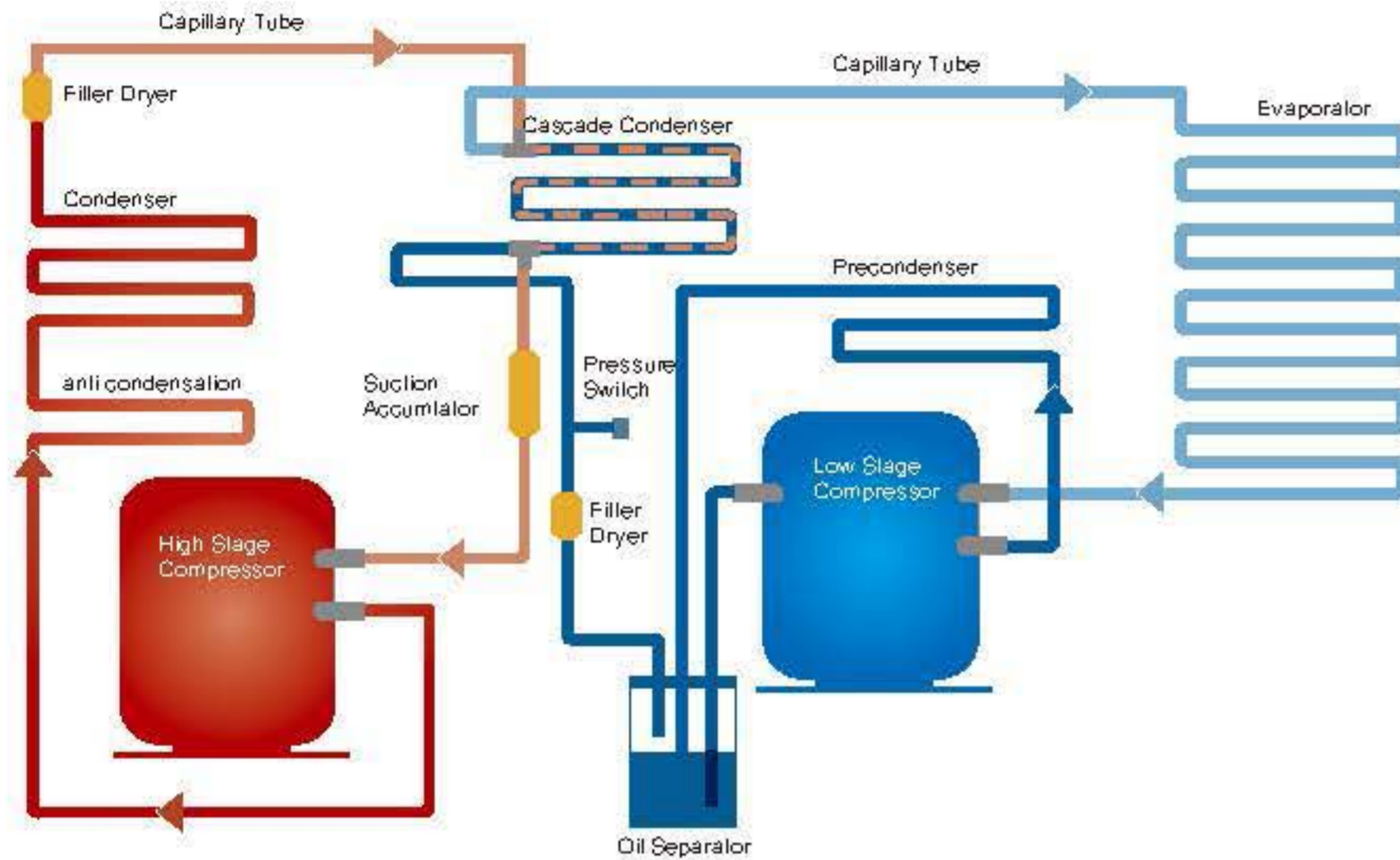

- Unique door seal design for the minimum loss of cold temperature during a door opening
- High performance VIP insulation panels to minimize cabinet heat gain and to improve temperature stability
- Patented cabinet insulation system designed for optimal performance of cold storage temperature and minimal frost buildup
- Unique design of independent insulated inner door systems for independent access of storage space to provide the maximum protection of stored samples



Key design features

- Microprocessor-controlled system designed for controllable range of -40°C to -86°C for cabinet space with 1°C increment
- Large LED display for cabinet temperature, set temperature, ambient temperature, and input voltage
- Settable high temperature and low temperature alarms
- Automatic clean-filter alarm and sensor error alert
- Adjustable storage shelf height
- Optional temperature recorder, storage racks and storage boxes



	Filter dryer • Filtration and drying device for water and debris
	Capillary tube for high stage • Expansion device for high stage liquid refrigerant
	Capillary tube for low stage • Expansion device for low stage refrigerant
	High stage condenser • Extra-large air cooled condenser dissipates product heat content efficiently.
	Low stage evaporator • Heat exchanger for expanded low stage refrigerant
 	Ultra low noise compressor • Compressor provides reliable performance with ultra low noise • Specially designed low stage evaporator yields excellent temperature uniformity and recovery after loading and door opening. • Both high and low stage compressors are industrial grade hermetically sealed compressor designed for low temperature application. Sound level is extremely low.
	Cascade condenser • Heat exchanger between the high and low temperature stage in the system
	Temprite oil separator • Temprite oil separator can effectively separate oil and water so as to improve the refrigeration performance

Suitable for clinical, medical, scientific research, quarantine and other departments to store items under low temperature conditions. Applicable for universities, hospitals, disease prevention and control centres, blood stations, scientific research institutes, electronics and chemical enterprise laboratories and biomedical engineering research institutes. For storage of biological products and biological samples such as red and white blood cells, viruses, bone and bacteria. Also used for electronic devices and other materials used for cryogenic tests.



DW-86L100J



Energy Efficient, Safe and Reliable

High efficiency HC refrigeration system, optimised for energy efficiency delivering a power consumption figure of just 5.5kW/24hrs.



Personal ULT Storage

810mm cabinet height makes it easy to place on or under counter, saving storage space. Stackable design.



Ergonomic design

Ergonomic handle design ensures easy one-hand door opening.



Low noise

Optimized noise reduction cabinet and system design, emits sound level of only 46.8dB.

VIP insulation and multilayered sealing design

70mm insulating layer with 25mm VIP and 4 layers of gasket improves energy efficiency and reduces heat loss to deliver excellent warm up times in event of power failure.



Optional IoT Module

Real time monitoring of cabinet temperature, temperature setting, high and low temperature alarm value, temperature curve, alarm log and event log.

- User-settable parameters such as set point and alarms.
- Real-time cabinet temperature display, alarm information, power supply and compressor start/stop state.
- Standard USB port capable of storing > 15 years of operating data for compliance.



Filter is easy to remove and clean without the need for tools.

4 casters + 2-foot locks, easy to move, lock and level.

Double stainless-steel inner doors to prevent cooling loss when opening the outer door, easy to clean.

Ergonomic design for easy door opening and closing. Lockable and equipped with 4 keys as standard with the ability to add a padlock for extra security when required.



Microprocessor control system

- Microcomputer electronic thermostat, LED temperature display, display precision 0.1°C, adjustable cabinet temperature set point -40°C~86°C.
- Cabinet temperature/voltage/ambient temperature checking are available.
- Multiple alarm functions: high temperature alarm, low temperature alarm, sensor fault alarm, power failure alarm, low battery power alarm, open door alarm and high ambient temperature alert.
- Sound and light alarm mode, attachable to remote alarm interface.
- Battery backup alarm function operates continuously for >24hrs in the event of a power outage.
- Standard configuration: RS485 port and USB interface.
- Standard 5V power supply available for test equipment.
- Optional IoT module.



Superior thermal insulation performance

70mm super thick insulation layer design, aviation vacuum insulation material VIP, thickness of 25 mm or more, 4 layers of silicone seal, superior thermal insulation and energy saving effect.



Porthole

Portholes as standard, allows for independent testing of cabinet temperature.



Security lock

Standard door lock and padlock to ensure sample security and prevent unauthorised access.



USB data storage

Capable of storing more than 15 years of data.



Specifications

Model		DW-86L338	DW-86L338J	DW-86L338JA	DW-86L388J	DW-86L486E	DW-86L490J	DW-86L490JA	DW-86L578J	DW-86L578JA	DW-86L628E	
Technical Data	Cabinet Type	Upright			Upright	Upright	Upright		Upright	Upright	Upright	
	Climate Class	N			N	N	N		N	N	N	
	Cooling Type	Direct cooling			Direct cooling	Direct cooling	Direct cooling		Direct cooling	Direct cooling	Direct cooling	
	Defrost Mode	Manual			Manual	Manual	Manual		Manual	Manual	Manual	
	Refrigerant	HFC			HC	HC	HC		HC	HC	HC	
Performance	Sound level [dB(A)]	50			50	50	49		50	50	49	
	Cooling Performance [°C]	-86			-86	-86	-86		-86	-86	-86	
	Temperature Range [°C]	-40~-86			-40~-86	-40~-86	-40~-86		-40~-86	-40~-86	-40~-86	
Control	Controller	Micro processor			Micro processor	Micro processor	Micro processor		Micro processor	Micro processor	Micro processor	
	LCD Touch Screen	LED			LED	LED	LED		LED	LED	LED	
Electrical Data	Power Supply [V/Hz]	220~240/50		115/60	208~230/60	220~240/50		220~240/50	208~230/60	220~240/50	220~240/50	
	Power [W]	900		650	700	1000	900		1000	750	1000	
	Electrical Current [A]	7.5		11	7.5	8	10		8	9	11	
Dimensions	Capacity [L/Cu.Ft]	558/11.9		558/11.9	588/13.7	486/17.1		490/17.3	578/20.4		628/22.2	
	Net/Gross Weight [approx]	kg	258/278		258/278	255/286	290/310		295/335	300/330		301/323
		lbs	524.7/612.9		524.7/612.9	562.2/630.5	639.3/683.4		650.4/738.5	661.4/727.5		664.0/712.0
	Interior Dimension [W*D*H]	mm	465*630*1165		465*630*1165	485*716*1310	590*630*1310		590*630*1310	620*716*1310		760*630*1310
		in	18.3*24.8*45.9		18.3*24.8*45.9	18.3*28.2*51.6	23.3*24.8*51.6		23.2*24.8*51.6	24.4*28.2*51.6		29.9*24.8*51.6
	Exterior Dimension [W*D*H]	mm	812*893*1846		812*893*1846	830*998*1980	945*900*1980		880*900*1980	895*980*1980		1035*900*1980
		in	32.0*35.2*72.7		32.0*35.2*72.7	32.7*39.3*78.0	37.2*35.4*78.0		33.9*35.4*78.0	35.4*38.6*77.2		40.7*35.4*78.0
Packing Dimension [W*D*H]	mm	875*970*2010		875*970*2010	893*1078*2135	995*995*2150		925*985*2150	950*1055*2125		1080*965*2150	
	in	34.4*38.2*79.1		34.4*38.2*79.1	35.2*42.4*84.1	39.2*39.2*84.6		36.4*38.8*84.6	37.4*41.5*83.7		42.5*38.0*84.6	
Container load [20/40/40'H]	12/24/24		12/24/24		12/24/24	12/24/24		12/24/24	12/24/24		12/24/24	
Alarms	High/Low Temperature	Y			Y	Y	Y		Y	Y	Y	
	Hot Condenser	Y			Y	Y	Y		Y	Y	Y	
	Power Failure	Y			Y	Y	Y		Y	Y	Y	
	High/Low Voltage	Y			N/A	N/A	N/A		N/A	N/A	N/A	
	Sensor Error	Y			Y	Y	Y		Y	Y	Y	
	Low Battery	Y			Y	Y	Y		Y	Y	Y	
	High Ambient Temperature	Y			Y	Y	Y		Y	Y	Y	
	Door Ajar	Y			Y	Y	Y		Y	Y	Y	
Accessories	Caster	Y			Y	Y	Y		Y	Y	Y	
	Foot	Y			Y	Y	Y		Y	Y	Y	
	Port hole	Y/1			Y/2	Y/2	Y/2		Y/2	Y/2	Y/2	
	Shelves/Inner doors	3/2			3/2	3/2	3/4		3/4	3/4	3/4	
	USB Interface	Y			Y	Y	Y		Y	Y	Y	
	Remote Alarm [Dry contacts]	Y			Y	Y	Y		Y	Y	Y	
	5V Power Supply Port	N/A			Y	Y	Y		Y	Y	Y	
	Temperature Recorder	Optional			Optional	Optional	Optional		Optional	Optional	Optional	
	RS232/485 Port	Optional			Optional	Optional	Optional		Optional	Optional	Optional	
	CO ₂ Backup System	Optional			Optional	Optional	Optional		Optional	Optional	Optional	
LN ₂ Backup System	Optional			Optional	Optional	Optional		Optional	Optional	Optional		
Others	Certification	CE	CE	UL	CE	CE	CE	UL	CE,ENERGYSTAR	UL	CE	

Product appearance and specifications are subject to change without notice.
DW-86L338J/490J/578/628/959 stainless steel interior optional



Specifications

Model	DW-86L728J		DW-86L728JA		DW-86L828J		DW-86L828JA		DW-86L100J		DW-86W100J		DW-86W420J		DW-86W420JA		
Technical Data	Cabinet Type	Upright				Upright				Upright		Chest		Chest			
	Climate Class	N				N				N		N		N			
	Cooling Type	Direct cooling				Direct cooling				Direct cooling		Direct cooling		Direct cooling			
	Defrost Mode	Manual				Manual				Manual		Manual		Manual			
	Refrigerant	HC				HC				HC		HC		HC			
Performance	Sound level [dB(A)]	50				50	51.5		46.8		49		50				
	Cooling Performance (°C)	-86				-86				-86		-86		-86			
	Temperature Range (°C)	-40~-86				-40~-86				-40~-86		-40~-86		-40~-86			
Control	Controller	Microprocessor				Microprocessor				Microprocessor		Microprocessor		Microprocessor			
	LCD Touch Screen	LED				LED				LED		LED		LED			
Electrical Data	Power Supply [V/Hz]	220~240/50		115/60		208~230/60		220~240/50		120/60		220~240/50		220~240/50		208~230/60	
	Power [W]	1000		1000		1000		1100		680		680		550		1000	
	Electrical Current [A]	10		18		10		10		3		6.5		4		7.5	
Dimensions	Capacity [L/Cu.Ft]	728/25.7				828/29.2				100/3.5		100/3.5		420/14.8			
	Net/Gross Weight [approx]	kg	345/385		380/410		380/410		108/132		138/160		310/357				
		lbs	760.6/848.8		837.7/903.9		837.7/903.9		238/291		304.2/352.7		683.4/787.0				
	Interior Dimension [W*D*H]	mm	766*716*1310		870*716*1310		870*716*1310		330*481*630		470*450*480		1367*462*652				
		in	30.2*28.2*51.6		34.3*28.2*51.6		34.3*28.2*51.6		13x19x25		18.5*17.7*18.9		53.8*18.2*25.7				
	Exterior Dimension [W*D*H]	mm	1041*980*1980		1145*980*1980		1145*980*1980		770*660*810		769*825*1120		2130*870*1020				
		in	41.0*38.6*78.0		45.1*38.6*78.0		45.1*38.6*78.0		30x26x32		30.3*32.5*44.1		83.9*34.3*40.2				
Packing Dimension [W*D*H]	mm	1090*1050*2150		1190*1045*2150		1190*1045*2150		830*710*970		845*855*1250		2195*895*1130					
	in	42.9*41.3*84.6		46.9*41.1*84.6		46.9*41.1*84.6		32x28x38.5		33.3*33.7*49.2		90.6*38.2*45.8					
Container load [20'/40'/40H]	12/20/20		8/20/20		8/20/20		44/88/88		12/24/48		6/12/24						
Alarms	High/Low Temperature	Y				Y				Y		Y		Y			
	Hot Condenser	Y				Y				Y		Y		Y			
	Power Failure	Y				Y				Y		Y		Y			
	High/Low Voltage	N/A				N/A				Y		N/A		N/A			
	Sensor Error	Y				Y				Y		Y		Y			
	Low Battery	Y				Y				Y		Y		Y			
	High Ambient Temperature	Y				Y				Y		Y		Y			
	Door Ajar	Y				Y				Y		Y		Y			
Accessories	Caster	Y				Y				Y		Y		Y			
	Foot	Y				Y				Y		Y		Y			
	Porthole	Y/2				Y/2				Y/1		Y/1		Y/1			
	Shelves/Inner doors	3/4				3/4				1/2		-/1		-/3			
	USB Interface	Y				Y				Y		Y		Y			
	Remote Alarm	Y				Y				Y		Y		Y			
	SV Power Supply Port	Y				Y				Y		N/A		N/A			
	Temperature Recorder	Optional				Optional				/		Optional		Optional			
	Rs232/485 Interface	Optional				Optional				-/Y		Optional		Optional			
	CO ₂ Backup System	Optional				Optional				Optional		Optional		Optional			
LN ₂ Backup System	Optional				Optional				Optional		Optional		Optional				
Others	Certification	CE,ENERGY STAR		UL		CE,ENERGY STAR		UL		CE		CE		CE		UL	

Product appearance and specifications are subject to change without notice

Advantage

- Small footprint, light and easy for installation
- User adjustable temperature setting
- Simple to program and operate
- Flexible – Can be installed on any ULT freezer, which has a port hole
- The CO₂ injection pipe is designed in combination of filter, to prevent the blockage of CO₂ back-up system

Safety

- Liquid CO₂ test button to ensure the backup system is working
- Low CO₂ alarm system alerts the user when liquid CO₂ bottle is low in liquid level
- Ultra-low sound level compressors

Reliability

- Stainless steel covering, more elegant
- Stainless steel input pipe design, allows for flexibility and ease of cylinder positioning
- Durable battery lasts up to 48 hours



Specifications

	Model	HBX-1C
Technical Data	Cabinet Type	Horizontal
	Climate Class	N
	Cooling Type	Direct cooling
	Refrigerant	CO ₂
Performance	Cooling Performance [°C]	-70
	Temperature Range [°C]	-40--70
Control	Controller	Thermostat
	Display	LED
Electrical Data	Power Supply [V/Hz]	220-240/50 208-230/60 115/60
	Power [W]	20
	Electrical Current [A]	0.25
Dimensions	Net/Gross Weight [approx]	11.2/14 24.7/30.86
	Exterior Dimensions [W*D*H]	200*400*160 7.8*15.7*6.3
	Packing Dimensions [W*D*H]	370*530*330 14.6*20.9*13
	CO ₂ Margin Insufficient Alarm	Y
Alarms	Low Battery Alarm	Y
	Sensor Error Alarm	Y
	Main Power Off Alarm	Y
	Charge Indicator	Y
	CO ₂ Injection Test Button	Y
Accessories	Foot	4
Others	Certification	CE/UL

Product appearance and specifications are subject to change without notice

LN₂ Backup System

LN₂ backup cooling system is an independent refrigeration system for a ULT freezer. When there is a loss of power or the temperature of the freezer rises to the high alarm set point, the LN₂ backup system can be automatically activated to inject LN₂ into the chamber to maintain the freezer temperature. The backup system operates on a rechargeable battery when there is a loss of main power.



Features

- Interlocked design to turn off the LN₂ injection when the door is opened
- Protection circuit to prevent over-charging battery
- Light weight and portable design, suitable for installation on top of a freezer
- Alarm functions to include low battery and sensor error

Specifications

	Model	HBX-1IA
Technical Data	Cabinet Type	Horizontal
	Cooling Type	Direct cooling
	Refrigerant	LN ₂
Performance	Cooling performance [°C]	-135
	Temperature Range [°C]	-90--135
Control	Controller	Thermostat
	Display	LED
Electrical Data	Power Supply [V/Hz]	220-240/50 208-230/60 115/60
	Power [W]	20
	Electrical Current [A]	0.05
Dimensions	Net/Gross Weight (approx)	15/17 33.1/37.5
	Exterior Dimensions [W*D*H]	360*305*445 14.2*12.0*17.5
	Packing Dimensions [W*D*H]	417*357*698 16.4*14.1*27.5
Alarms	Low Battery Alarm	Y
	Sensor Error Alarm	Y
	Main Power Off Alarm	Y
	Charge Indicator	Y
Others	Certification	CE/UL

Product appearance and specifications are subject to change without notice



Consumables for ULT Freezer

SBS RACKED 2D CRYOGENIC VIAL

Introduction

Biomedical SBS Racked 2D Cryogenic Vials are widely used in many labs, sample banks and biopharmaceutical companies.

The vials have clear easily legible laser etched data matrix code on bottom which is compatible with automated storage for minimum manual intervention. Screw cap and push cap are available, screw cap is with single turn thread which can be operated easily, push cap is designed for the prevention of cap drop during unfreezing.

SBS racked cryo vials are available of storage over vapor phase liquid nitrogen at temperature of -196°C.

biomedical SBS racked Cryogenic Vials are produced in 10000 grade clean room, they are DNase-free, RNase-free and Non-Pyrogenic.



Technical Specification

- Low temperature storage from -196°C to 121°C
- Sterilization Level: SAL 10-6
- Non-Pyrogenic; free of endotoxins, ATP and mutagen

Product Feature

- 2D laser-etched code on bottom
- Chemically resistant, easy operation and tracking
- shaped bottom for maximum working volume
- Screw cap and push cap for choice
- Available in transparent, white, blue, orange and green cap
- Barcode on rack for tracking

Specifications

Type	Model	Volume	2D Barcode	Sterilization	Temperature Range	Unit
Internal Thread	T6101	0.75ml	Y	Gamma	-196-121°C	96 sets/box
	T6201	1.4ml	Y	Gamma	-196-121°C	96 sets/box
External Thread	T6301	1.0ml	Y	Gamma	-196-121°C	48 sets/box
	T6401	2.0ml	Y	Gamma	-196-121°C	48 sets/box
	T6121	0.8ml	Y	Gamma	-196-121°C	96 sets/box
	T6221	1.45ml	Y	Gamma	-196-121°C	96 sets/box

INNOVATIVE CRYOGENIC VIAL

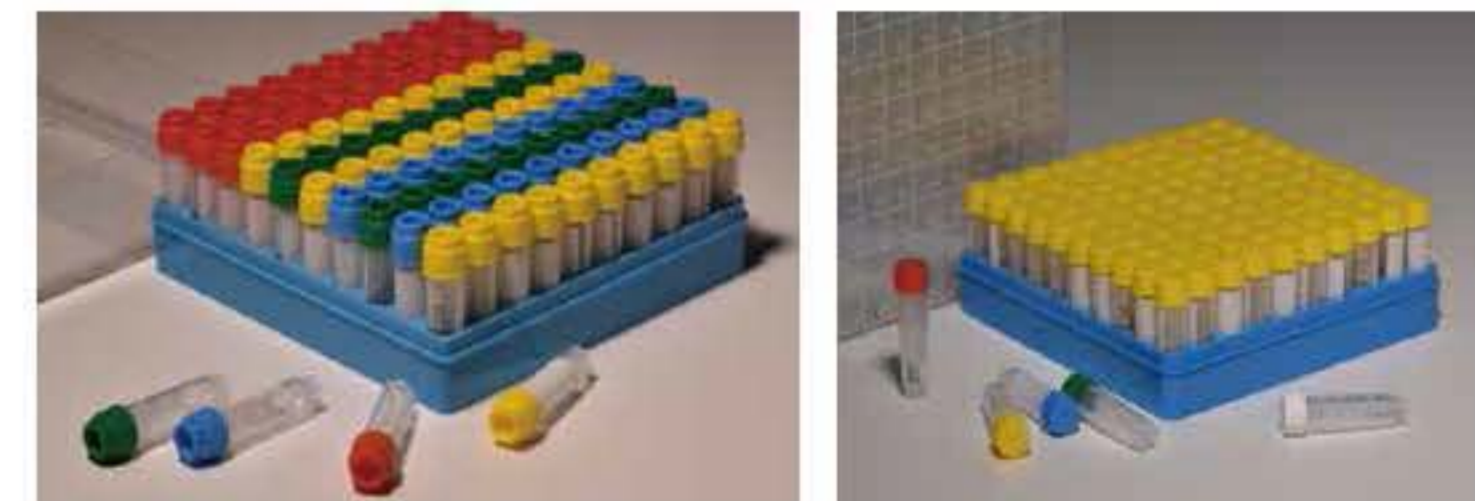

Technical Specification

- Temperature storage range: -196°C to 121°C
- Sterilization Level: SAL10-6
- Non-Pyrogenic; free of endotoxins, ATP and mutagen
- DNase-free, RNase-free
- Laser-etchen 2D barcode

Product Feature

- Volume: 0.5ml, 1.5ml, small quantity of samples can be packed separately to avoid repeated freezing and thawing of samples and increase the packing quantity of samples
- Cap: external thread, plane or concave
- Bottom: self-standing and conical
- Cap color: orange, yellow, green, blue

Specifications

Model	Volume	Sterile	Description	Unit
T2053	0.5ml	Gamma	Non-2D, box pack	100 sets/box, 12 boxes/case
T2054	0.5ml	Gamma	Non-2D, bag pack	100 sets/bag, 1000 sets/case
T2203	1.5ml	Gamma	Non-2D, box pack	100 sets/box, 12 boxes/case
T2204	1.5ml	Gamma	Non-2D, bag pack	100 sets/bag, 1000 sets/case
T2051	0.5ml	Gamma	2D barcode on bottom, box pack	100 sets/box, 12 boxes/case
T2052	0.5ml	Gamma	2D barcode on bottom, bag pack	100 sets/bag, 1000 sets/case
T2201	1.5ml	Gamma	2D barcode on bottom, box pack	100 sets/box, 12 boxes/case
T2202	1.5ml	Gamma	2D barcode on bottom, bag pack	100 sets/bag, 1000 sets/case
T2051-1	0.5ml	Gamma	2D barcode on bottom, side on numbers, box pack	100 sets/box, 12 boxes/case
T2052-1	0.5ml	Gamma	2D barcode on bottom, side on numbers, bag pack	100 sets/bag, 1000 sets/case
T2201-1	1.5ml	Gamma	2D barcode on bottom, side on dimensional code and numbers, box pack	100 sets/box, 12 boxes/case
T2202-1	1.5ml	Gamma	2D barcode on bottom, side on dimensional code and numbers, bag pack	100 sets/bag, 1000 sets/case

*Please consult your local dealer for more specifications

CONVENTIONAL CRYOGENIC VIAL

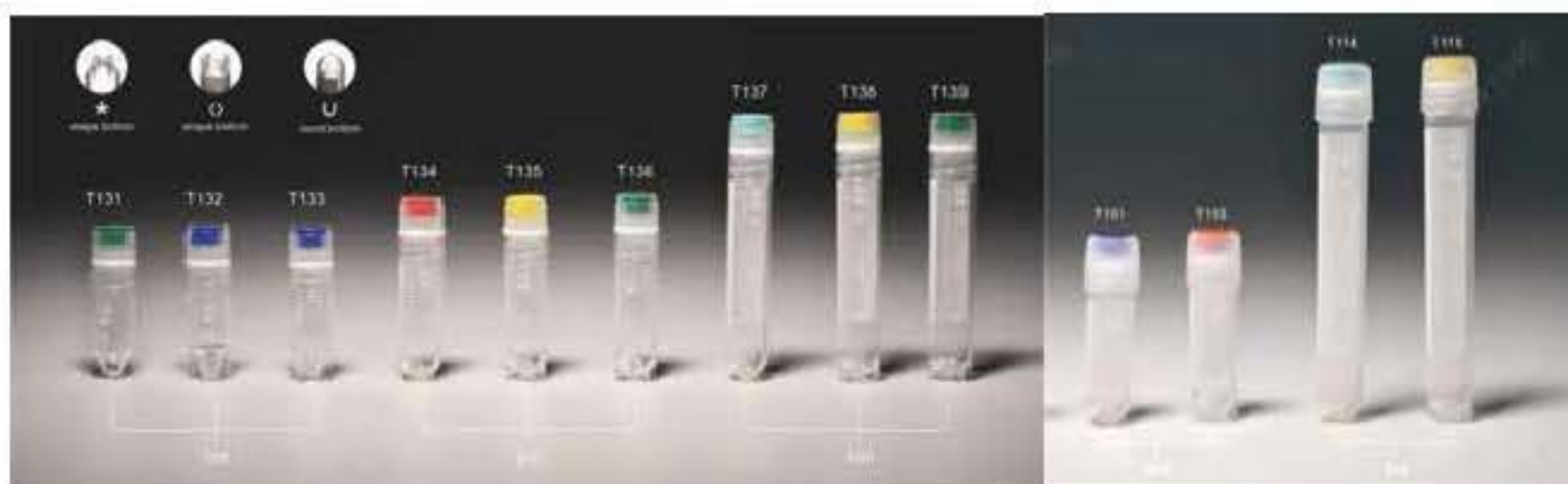

Technical Specification

- Temperature storage range: -196°C to 121°C
- Sterilization Level: SAL 10⁻⁶
- Non-Pyrogenic; free of endotoxins, ATP and mutagen
- DNase-free, RNase-free

Product Feature

- Volume: 0.5ml, 1ml, 1.5, 2ml, 4ml, 5ml
- Cap: internal/external thread
- Bottom: skired or round
- Color coded cap inserts: red, blue, yellow, green, white

Specifications

Type	Model	Volume	Bottom	Style	Sterile	Temperature Range	Unit
External Thread	T118	0.5ml	U	Round	/	-90-121°C	100sets/bag, 1000 sets/case
	T119	0.5ml	M	Self standing	/	-90-121°C	100sets/bag, 1000 sets/case
	T105	1.8ml	U	Self standing	/	-90-121°C	50sets/bag, 1000 sets/case
	T102	2.0ml		Self standing	Gamma	-196-121°C	50 sets/bag, 1000 sets/case
	T114	5.0ml	U	Round	Gamma	-196-121°C	50 sets/bag, 1000 sets/case
	T115	5.0ml		Self standing	Gamma	-196-121°C	50 sets/bag, 1000 sets/case
Internal Thread	T132	1.0ml		Self standing	Gamma	-196-121°C	50 sets/bag, 1000 sets/case
	T135	2.0ml		Self standing	Gamma	-196-121°C	50 sets/bag, 1000 sets/case
	T137	4.0ml	U	Round	Gamma	-196-121°C	50 sets/bag, 1000 sets/case
	T138	4.0ml		Self standing	Gamma	-196-121°C	50 sets/bag, 1000 sets/case
Colorcode	T144	/	/	/	/	/	1000 sets/bag, available in six different colours

Laboratory Consumables

FREEZER BOXES

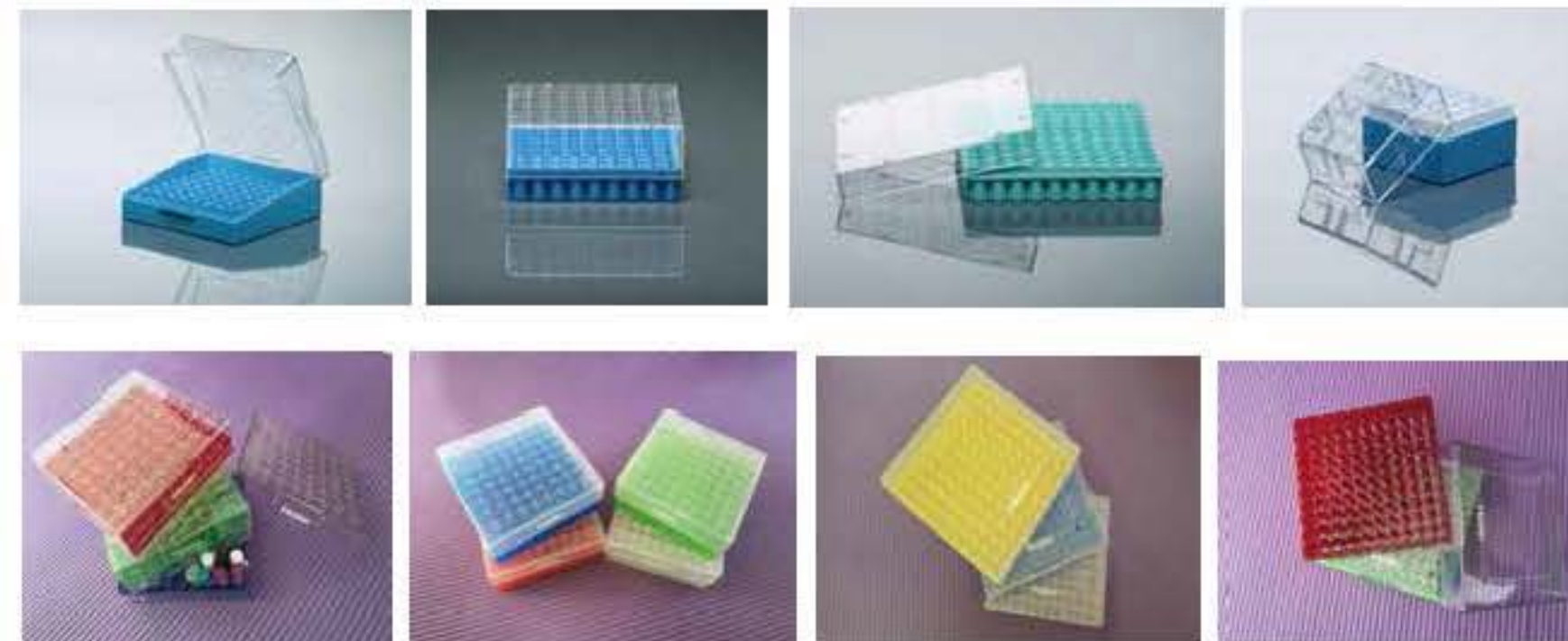

Technical Specification

- Sizes: 4*4 (16 well), 5*5 (25 well), 9*9 (81 well), 10*10 (100 well)
- Material: papery, high-transparent PP/PC
- Temperature storage range: -86°C and -196°C to 121°C

Product Feature

- Visible for checking without rack open
- Lid with printed grip and number for convenience of inventory management
- Specially designed gap and vents for quick refrigeration and liquid remove
- Standard sizes compatible with most freezer racks

Specifications

Model	Description	Dimension(mm)	Material	Temperature
T130 (ABS)	81well	133*133*53	PP	-86°C-121°C
HBB-200-PP (2015)	100well	133*133*53	PP	-86°C-121°C
HBB-281-PC (2015)	81/100well	133*133*53	PC	-196°C-121°C
T130	81well	133*133*53	PP,PC	-196°C-121°C
T142	100well	133*133*53	PP,PC	-196°C-121°C
T142-2	81/100well, flip	133*133*53	PC	-196°C-121°C

CENTRIFUGE TUBE



Product Feature

- Capacity selection: 0.5ml, 1.5ml, 2ml, 15ml, 50ml
- The bottom of the tube is designed with Cone-bottom and free-standing
- Maximum relative centrifugal force (RCF) 10000 xg
- Suitable temperature range: -80°C to 120°C
- No DNase, RNase, no pyrogen, can prevent the sample from being contaminated
- A variety of packages including sealed bags, foam racks and plastic racks

Specifications

Type	Sterile	Package	Description	Package quantity
15ml centrifuge tube	Y	Zippered bag	Circular cone bottom	25 pcs/bag, 500 pcs/case
	Y	Plastic rack	Circular cone bottom	50 pcs/rack, 1000 pcs/case
50ml centrifuge tube	Y	Zippered bag	Circular cone bottom	25 pcs/bag, 500 pcs/case
	Y	Zippered bag	Self-stand bottom	25 pcs/bag, 500 pcs/case
0.5ml microcentrifuge tube	Y	Zippered bag	Cone-bottom	500 pcs/pack, 5000 pcs/case
1.5ml microcentrifuge tube	Y	Zippered bag	Cone-bottom	500 pcs/pack, 5000 pcs/case
2.0ml microcentrifuge tube	Y	Zippered bag	Round-bottom	500 pcs/pack, 5000 pcs/case

PIPET TIPS

The pipette tip uses USP grade VI polypropylene (PP) as the raw material. The excellent internal structure design is suitable for most brand pipettes, and can ensure that the pipette tip and pipette are well sealed. The surface of the tip is smooth, with low adsorption, high transparency and high accuracy. The product is sterilized, without DNA/RNase, without heat source, without endotoxin.



Product Feature

- USP class VI polystyrene (PP) raw materials
- 10µl, 200µl, 1000µl
- Two options with and without filter, transparent color
- DNase-free, RNase-free
- No heat source, no endotoxin
- Packed in bags or boxes



Specifications

Model	Description	Packing Specification	
		Package	Unit Qty
P900106	10µl transparent tip, in normal bag	1000 pcs/bag, 20 bags/case	20000
P900107	10µl transparent tip, boxed, sterile	96 pcs/box, 10 boxes/medium box, 5 medium boxes/case	4800
P900108	10µl transparent tip, with filter element, boxed, sterile	96 pcs/box, 10 boxes/medium box, 5 medium boxes/case	4800
P900109	10µl transparent tip, with filter element, in normal bag	1000 pcs/bag, 20 bags/case	20000
P902001	200µl yellow tip, in normal bag	1000 pcs/bag, 20 bags/case	20000
P902002	200µl yellow tip, boxed, sterile	96 pcs/box, 10 boxes/medium box, 5 medium boxes/case	4800
P902003	200µl yellow tip, with filter element, boxed, sterile	96 pcs/box, 10 boxes/medium box, 5 medium boxes/case	4800
P902004	200µl yellow tip, with filter element, in normal bag	1000 pcs/bag, 20 bags/case	20000
P910001	1000µl blue tip, in normal bag	1000 pcs/bag, 5 bags/case	5000
P910002	1000µl blue tip, boxed, sterile	96 pcs/box, 6 boxes/medium box, 5 medium boxes/case	2880
P910003	1000µl blue tip, with filter element, boxed, sterile	96 pcs/box, 6 boxes/medium box, 5 medium boxes/case	2880
P910004	1000µl blue tip, with filter element, in normal bag	1000 pcs/bag, 5 bags/case	5000

PCR TUBE

Product Feature

- USP grade VI polystyrene (PP) raw materials
- 0.1ml, 0.2ml two specifications
- No DNase, no RNase
- No heat source, no endotoxin
- Single tube, eight row tube, 96-well plate three types are optional



Specifications

Model	Name	Description	Sterile	Packing Specification	
				Package	Unit Qty
T002-1	0.2 ml PCR tube	Cone-bottom	Y	1000 pcs/bag, 10 bags/box	10000
T016-1	0.2ml PCR 8 straight tubes	Cone-bottom	Y	125 sets/box, 10 boxes/box	1250
T096-1	0.1ml-96 well plate without hemline	Cone-bottom	Y	5 pcs/bag, 5 bags/medium box, 6 medium box/case	150
T096-2	0.2ml-96 well plate without hemline	Cone-bottom	Y	5 pcs/bag, 5 bags/medium box, 6 medium box/case	150
T096-3	0.1ml-96 well plate without hemline	Cone-bottom	Y	5 pcs/bag, 5 bags/medium box, 6 medium box/case	150
T096-4	0.2ml-96 well plate without hemline	Cone-bottom	Y	5 pcs/bag, 5 bags/medium box, 6 medium box/case	150

Freezer Racks

Our freezer racks fit various sizes of freezers and they are compatible with freezer boxes provided by other manufacturers. These freezer racks improve freezer space utilization and satisfy storage requirements of biobanks.

◆Side-access freezer rack features:

- Frame and interior grids are made with 304 stainless steel for durability and better appearance.
- No sharp edges to avoid risk of injury.
- Steel plate thickness: Combination of 0.5 and 1.0 mm.
- Side-access design makes it convenient and economic.
- Suitable for common low temperature freezers.
- Perfectly suitable for standard sized freezer boxes.
- The front side is printed with Haier's stenciled seal.
- Provide personalized customization.



◆Sliding-drawer freezer rack features:

- Made with 304 stainless steel.
- Steel plate thickness: Combination of 0.5 and 1.0 mm.
- Sliding-drawer design for convenient operations.
- Low temperature rated plastic handles are standard on draw racks for ease and safety of operation.
- Labeling slots are standard on draws. The outward pouch design protects the slot from potential damage caused by low temperature.
- The front side is printed with Haier's stenciled seal.
- Provide personalized customization.



Specifications

Product	Model	Rack Description	Rack Dimension (W*D*H)	ULT Freezer Models
2 inch stainless steel rack	DCJ-44-A (2014)	2 inch stainless steel rack 4*4 [2 inch box *16]	138*565*240 [mm] 5.4*22.9*9.4 [in]	DW-338J/490J
	DCJ-44-B (2014)	2 inch stainless steel drawer rack 4*4 [2 inch box *16]	140*565*240 [mm] 5.5*22.9*9.4 [in]	
	DCJ-54-A (2014)	2 inch stainless steel rack 5*4 [2 inch box *20]	138*565*293 [mm] 5.4*22.2*11.5 [in]	DW-388A/486E/ 490/628E
	DCJ-54-B (2014)	2 inch stainless steel drawer rack 5*4 [2 inch box *20]	140*565*293 [mm] 5.5*22.2*11.5 [in]	
	DCJ-55-A (2014)	2 inch stainless steel rack 5*5 [2 inch box *25]	138*685*293 [mm] 5.4*27.0*11.5 [in]	DW-86L388J/418S/418ST/ 578S/578ST/579/579BP/579BPT/728J/728JA/ 728S/728ST/729/729BP/729BPT/828J/828JA/ 828S/828ST/829/829BP/829BPT/828W/ 829BP/828W DW-86L959BP/959BPT/959W
	DCJ-55-B (2014)	2 inch stainless drawer rack 5*5 [2 inch box *25]	140*685*293 [mm] 5.5*27.0*11.5 [in]	
	DCJ-08-A (2014)	2 inch stainless steel drawer rack 8*1 [2 inch box *8]	140*140*480 [mm] 5.5*5.5*18.9 [in]	
	DCJ-10-A (2014)	2 inch stainless steel rack 10*1 [2 inch box *10]	140*140*600 [mm] 5.5*5.5*23.6 [in]	DW-86W100J
				DW-86W420J/DW-150W200/ DW-150W200J

Haier ULT Freezer + Consumables Solutions

Specifications

Freezer Model	Freezer Rack Model	Description	Freezer Rack Quantity	Freezer Box Quantity	Cryo Tube Quantity (2ml)
DW-86L338J/338JA	DCJ-54-A (2014) [Middle, 2 layers]	2 inch stainless steel side-access freezer rack 5*4 [2 inch freezer box*20 units]	6	120	12000
	DCJ-54-B (2014) [Middle, 2 layers]	2 inch stainless steel sliding-drawer freezer rack 5*4 [2 inch freezer box*20 units]	6	120	12000
	DCJ-44-A (2014) [Top and bottom layers]	2 inch stainless steel side-access freezer rack 4*4 [2 inch freezer box*16 units]	6	96	9600
	DCJ-44-B (2014) [Top and bottom layers]	2 inch stainless steel sliding-drawer freezer rack 4*4 [2 inch freezer box*16 units]	6	96	9600
DW-86L388J/418S/418ST	DCJ-55-A (2014)	2 inch stainless steel side-access freezer rack 5*5 [2 inch freezer box*25 units]	12	240	24000
	DCJ-55-B (2014)	2 inch stainless steel sliding-drawer freezer rack 5*5 [2 inch freezer box*25 units]	12	300	30000
DW-86L486E	DCJ-54-A (2014)	2 inch stainless steel side-access freezer rack 5*4 [2 inch freezer box*20 units]	16	320	32000
	DCJ-54-B (2014)	2 inch stainless steel sliding-drawer freezer rack 5*4 [2 inch freezer box*20 units]	16	320	32000
DW-86L419/490J/490JA	DCJ-54-A (2014) [Top 2 layers]	2 inch stainless steel side-access freezer rack 5*4 [2 inch freezer box*20 units]	8	160	16000
	DCJ-54-B (2014) [Top 2 layers]	2 inch stainless steel sliding-drawer freezer rack 5*4 [2 inch freezer box*20 units]	8	160	16000
	DCJ-44-A (2014) [Bottom 2 layers]	2 inch stainless steel side-access freezer rack 4*4 [2 inch freezer box*16 units]	8	128	12800
	DCJ-44-B (2014) [Bottom 2 layers]	2 inch stainless steel sliding-drawer freezer rack 4*4 [2 inch freezer box*16 units]	8	128	12800
DW-86L628E	DCJ-54-A (2014)	2 inch stainless steel side-access freezer rack 5*4 [2 inch freezer box*20 units]	20	400	40000
	DCJ-54-B (2014)	2 inch stainless steel sliding-drawer freezer rack 5*4 [2 inch freezer box*20 units]	20	400	40000
DW-86L578J/578JA/578S/578ST/579/579BP/579BPT/579BPT	DCJ-55-A (2014)	2 inch stainless steel side-access freezer rack 5*5 [2 inch freezer box*25 units]	16	400	40000
	DCJ-55-B (2014)	2 inch stainless steel sliding-drawer freezer rack 5*5 [2 inch freezer box*25 units]	16	400	40000
DW-86L728J/728JA/728S/728ST/729/729BP/729BPT	DCJ-55-A (2014)	2 inch stainless steel side-access freezer rack 5*5 [2 inch freezer box*25 units]	20	500	50000
	DCJ-55-B (2014)	2 inch stainless steel sliding-drawer freezer rack 5*5 [2 inch freezer box*25 units]	20	500	50000
DW-86L828J/828JA/828S/828ST/829/829BP/829BPT/828W/829BP/828W	DCJ-55-A (2014)	2 inch stainless steel side-access freezer rack 5*5 [2 inch freezer box*25 units]	24	600	60000
	DCJ-55-B (2014)	2 inch stainless steel sliding-drawer freezer rack 5*5 [2 inch freezer box*25 units]	24	600	60000
DW-86L959BP/959BPT/959W	DCJ-55-A (2014)	2 inch stainless steel side-access freezer rack 5*5 [2 inch freezer box*25 units]	28	700	70000
	DCJ-55-B (2014)	2 inch stainless steel sliding-drawer freezer rack 5*5 [2 inch freezer box*25 units]	28	700	70000
DW-86L100J	DCJ-53-A (2014)	2 inch stainless steel side-access freezer rack 5*3 [2 inch freezer box*15 units]	4	60	6000
	DCJ-53-B (2014)	2 inch stainless steel sliding-drawer freezer rack 5*3 [2 inch freezer box*15 units]	4	60	6000
DW-86W420J/420JA	DCJ-10-A (2014)	2 inch chest-type freezer rack [2 inch freezer box*10 units]	27	270	27000
DW-86W100J	DCJ-08-A (2014)	2 inch chest-type freezer rack [2 inch freezer box*8 units]	9	72	72000
DW-150W200	DCJ-10-A (2014)	2 inch chest-type freezer rack [2 inch freezer box*10 units]	12	120	12000
DW-150W200J	DCJ-12-A	2 inch chest-type freezer rack [2 inch freezer box*12 units]	12	144	14400

Biomedical Freezer



A versatile low-temperature freezer installed in hospitals, blood stations, diseases control & prevention centers, research institutions, bioscience laboratories and medical laboratories. It is suitable for storing a wide variety of biological products including viruses, bacteria, red blood cells, white blood cells, skin, bone and semen as well as ocean-going supplies and electronic devices. It can also provide a low-temperature environment for testing of special materials.

The secondary application is for the storage of fishery products such as tuna, Australian lobster, salmon, South American shrimps, Argentina red shrimp, top-quality beef, kanpachi, octopus, yellowtail, bonito fish, grouper, and fugu rubripes. This is a requirement for fishery products for human consumption and hence these freezers are popular among professional oceanic fisherman, seafood distributors, speciality seafood stores and sushi restaurants and commercial food manufacturers.



Dual-seal design



Efficient and reliable fan



German made energy efficient compressor



Digital temperature control display



Quickly freeze sea food products to retain their original taste, structure and freshness.



Low noise output, noise cancelling technology yields a smoother operation and a sound level of less than 43 dB(A).



Multiple alarm system includes temperature alarm, and sensor error alarm.



HC refrigerant system is optimized to improve refrigeration efficiency by 30% and save energy by about 50%.

Single compressor auto cascade refrigeration system provides high efficient cooling power. Insulation thickness is 100 mm for optimal protection of cold temperature and saving energy.



Creative dual seals design retains cold temperature more effectively, and eliminates condensation on gaskets.



Interior material is certified food grade 304 stainless steel, ensuring safe contact between food and interior liner.



Interior lock design ensures product safety. Lockable casters permit ease of installation and maneuvering.



Water proof digital control delivers precise temperature for storage. Display and control system are easy to use.

Specifications

	Model	DW-60W138	DW-60W258	DW-60W388	
Technical Data	Cabinet Type	Chest	Chest	Chest	
	Climate Class	N	N	N	
	Cooling Type	Direct Cooling	Direct Cooling	Direct Cooling	
	Refrigerant	R600a/R1150	R600a/R1150	R600a/R1150	
	Sound Level [dB(A)]	43	43	43	
Performance	Cooling performance [°C]	-60	-60	-60	
	Temperature Range [°C]	-30--60	-30--60	-30--60	
Control	Controller	Microprocessor	Microprocessor	Microprocessor	
	Display	LED	LED	LED	
Electrical Data	Power Supply [V/Hz]	220-240/50	220-240/50	220-240/50	
	Power [W]	370	410	420	
	Electrical Current [A]	3	3	3.5	
Dimensions	Capacity [L/Cu.Ft]	138/4.9	258/9.1	388/13.7	
	Net/Gross Weight [approx]	kg	62/75	88/108	105/130
		lbs	137/165	194/238	232/287
	Interior Dimensions [W*D*H]	mm	580*445*620	1000*445*620	1450*445*620
		in	22.8*17.5*24.4	39.4*17.5*24.4	57.1*17.5*24.4
	Exterior Dimensions [W*D*H]	mm	790*770*950	1210*770*950	1655*770*950
		in	31.1*30.3*37.4	47.6*30.3*37.4	65.2*30.3*37.4
Packing Dimensions [W*D*H]	mm	815*800*990	1255*800*990	1695*800*990	
	in	32.1*31.5*39	49.4*31.5*39	66.7*31.5*39	
	Container Load [20'/40'/40'H]	28/56/56	22/46/46	14/28/28	
Alarms	High/Low Temp	Y	Y	Y	
	Sensor Error	Y	Y	Y	
Accessories	Caster	Y	Y	Y	
	Porthole	Y	Y	Y	
Others	Certification	CE	CE	CE	

Product appearance and specifications are subject to change without notice

-40°C Biomedical Freezer (Double Doors Type)

The double door -40°C biomedical freezer models offer a large capacity storage space with rapid cooling. Integrated design of cold shelf and evaporator provides additional refrigeration efficiency. Designed to store vaccines, blood plasma and many other biological materials. Installations can be found in research institutions and clinical sites in the life science, pharma, biotech, medical and electronics sectors.



DW-40L508

DW-40L348



Control panel



Drawer



Shelf

-40°C Biomedical Freezer (Double Doors Type)

The DW-40L348 is based on the original work horse platform of DW-40L508. The new freezer model operates with two capillary tubes and is equipped with dual gaskets to improve the temperature uniformity through the chamber drastically. It can be installed to satisfy tougher application requirements in universities, research institutions and blood banks.

Reliability and Key Features

- Rated for -40°C at 32°C ambient
- Rapid cooling with shelf evaporator
- Improved temperature uniformity with dual capillary tube design at the range of -20°C to -40°C
- Improved door seal design with two gaskets maintains cabinet temperature more efficiently
- Reduced frost buildup
- 90mm insulation thickness for additional robustness, less power consumption and better temperature retaining ability
- Drawer design maximizes storage space. One unit can hold 360 bags of 230 ml blood bags
- Optional USB interface

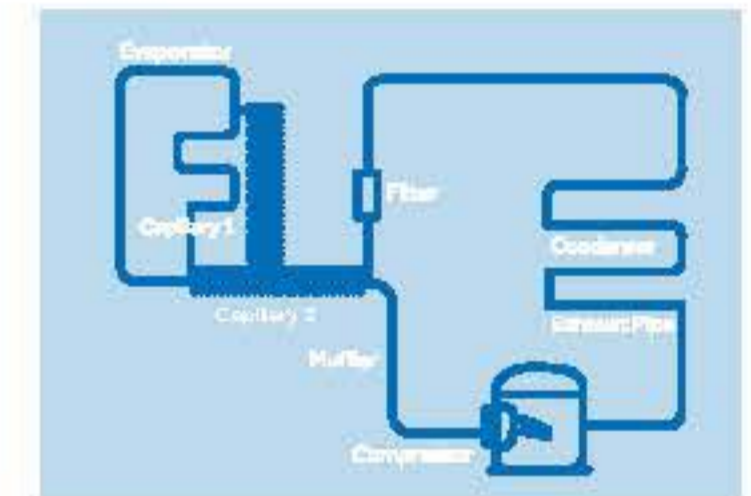

Safety

- Multiple malfunction alarms include high/low temperature, power failure, sensor error, low battery, high ambient temperature
- Two types of alarms: buzzer and flashing light, remote alarm



Ergonomic Design

- LED digital display for clear observation
- Double door design with independent locks reduces air leakage to ensure temperature stability and lower power consumption
- Tracks to label drawers for product identification





Key Features

- Microprocessor control, adjustable temperature range: -20°C to -40°C
- LED digital display and increment at 0.1°C
- Permanently lubricated cooling fan for safety and longevity
- Rapid cooling with shelf evaporator
- Removable double outer door seal design, good sealing effect and energy saving

Ergonomic Design

- USB data logging and temperature recorder (optional)
- Padlock with stainless steel cylinder for safe storage
- Drawers are designed with label holders for item identification

Safety

- Multiple malfunction alarms include high/low temperature, sensor error, power failure, high ambient temperature, low battery, door ajar
- Alarm Types: buzzer, flashing light, remote alarm



Reliable Performance



USB



Malfunction Alarms



Double Outer Door Seal



Padlock



Caster and feet



Removable double outer door seal



Reliability and Key Features

- High efficiency low temperature compressor with known field reliability
- Chemically stable, CFC-free, commercially available and environmentally safe refrigerant
- Permanently lubricated cooling fan for safety and longevity, high density insulation foam for stable and long term storage temperature
- Optimized refrigeration system designed to maximize cooling effect and temperature uniformity
- Microprocessor control, digital display, adjustable temperature range: -20°C--40°C
- LCD digital display for clear observation
- Wide voltage tolerance design with applicable voltage range of 198-252 V/AC

Safety

- Multiple malfunction alarms to detect high/low temperature, sensor error and power failure
- Two types of alarm indications: audible buzzing and visual flashing light

Ergonomic Design

- Door lock for storage safety
- Standard ø25mm access port for testing
- Corrosion proof cabinet interior design
- Suitable for a variety of storage baskets



Inner

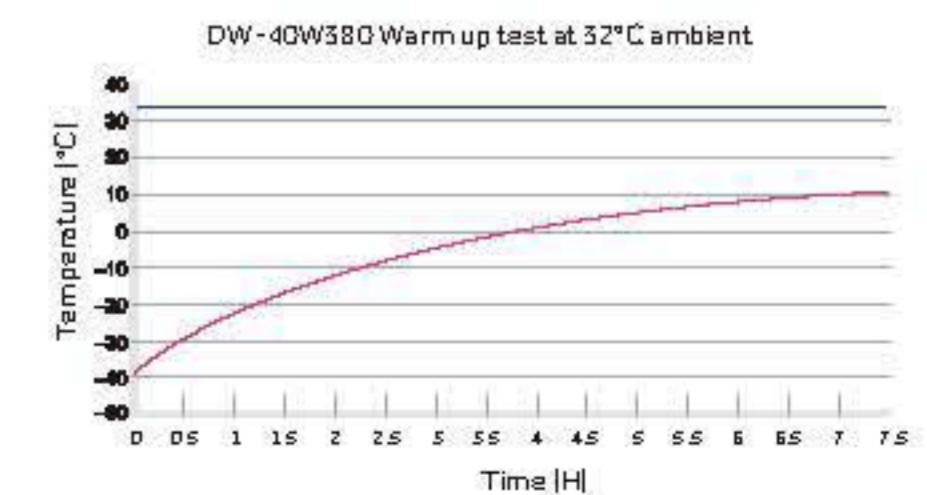
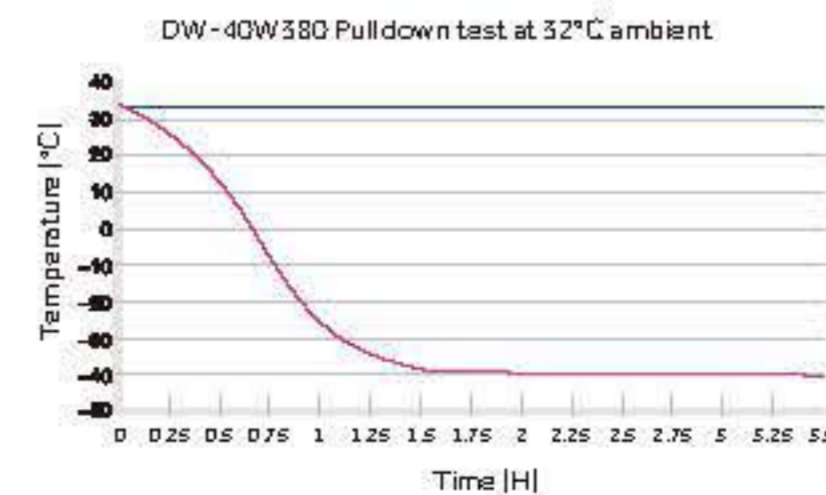



Specifications

Model	DW-40L92	DW-40L262		DW-40L278		DW-40L348	DW-40L508		DW-40W100	DW-40W255	DW-40W380		
Technical Data	Cabinet Type	Upright	Upright		Upright		Upright, Double Door	Upright, Double Door		Chest	Chest	Chest	
	Climate Class	4	4		4		4	4		4	4	4	
	Cooling Type	Direct Cooling	Direct Cooling		Direct Cooling		Direct Cooling	Direct Cooling		Direct Cooling	Direct Cooling	Direct Cooling	
	Defrost Mode	Manual	Manual		Manual		Manual	Manual		Manual	Manual	Manual	
	Refrigerant	HC	HC	CFC-Free	HC	CFC-Free	HC	HC	CFC-Free	CFC-Free	CFC-Free	CFC-Free	
Performance	Sound Level [dB(A)]	29	41	44	40	44	41	41	45	35	41	45	
	Cooling Performance [°C]	-40	-40		-40		-40	-40		-40	-40	-40	
Control	Temperature Range [°C]	-20--40	-20--40		-20--40		-20--40	-20--40		-20--40	-20--40	-20--40	
	Controller	Microprocessor	Microprocessor		Microprocessor		Microprocessor	Microprocessor		Microprocessor	Microprocessor	Microprocessor	
Electrical Data	Display	LED	LED		LED		LED	LED		LCD	LCD	LCD	
	Power Supply [V/Hz]	220-240/50	220-240/50/60	115/60	220-240/50	220-240/50/60	220-240/50	220-240/50	208-230/60	220-240/50	115/60	220-240/50/60	
	Power [W]	330	350	600	275	370	280	285	430	260	255	410	
Dimensions	Electrical Current [A]	2	2.2	7.5	2.9	5.1	2.9	2.9	2.9	2.5	5.0	2.5	
	Capacity [L/Cu.Ft]	92/3.3	262/9.3		278/9.8		348/12.3	490/17.3		100/3.5	255/9.0	380/13.4	
	Net/Gross Weight	kg	46/51	88/93		115/135		137/145	164/200		43/46	70/82	82/89
		lbs	101.4/112.4	194.0/205.0		253.5/297.6		302.0/320.0	361.6/440.9		94.8/101.4	154.3/180.8	180.8/196.2
	Interior Dimensions [W*D*H]	mm	435*410*635	480*465*1430		520*435*1230		535*610*1228	685*610*1228		500*385*630	1036*426*625	1375*453*640
		in	17.1*16.1*25.0	18.9*18.3*56.3		20.5*17.1*48.4		21.1*24.0*48.3	27.0*24.0*48.3		19.7*15.2*24.8	40.8*16.8*24.6	54.1*17.8*25.2
	Exterior Dimensions [W*D*H]	mm	640*610*860	700*705*1665		770*710*1810		790*845*1860	940*845*1860		685*650*810	1243*724*838	1554*724*838
		in	25.2*24.0*33.9	27.6*27.8*65.6		30.3*28.0*71.3		31.1*33.3*73.2	37.0*33.3*73.2		27.0*25.6*31.9	48.9*28.5*33.0	61.2*28.5*33.0
Packing Dimensions [W*D*H]	mm	660*700*935	775*760*1880		832*757*1992		852*927*2044	997*927*2044		740*650*880	1320*755*905	1635*760*900	
	in	26.0*27.6*36.8	30.5*29.9*74.0		32.8*29.8*78.4		33.5*36.5*80.5	39.3*36.5*80.5		29.1*25.6*34.6	52.0*29.7*35.6	64.4*29.9*35.4	
Container Load [20"/40"/40"H]		54/108/108	21/45/45		14/28/28		14/28/28	12/24/24		54/108/162	24/54/81	18/42/63	
Alarms	High/Low Temperature	Y	Y		Y		Y	Y		Y	Y	Y	
	Remote Alarm	N/A	N/A		Y		Y	Y		N/A	N/A	N/A	
	Power Failure	N/A	N/A		Y		Y	Y		Y	Y	Y	
	Sensor Error	Y	Y		Y		Y	Y		Y	Y	Y	
	Low Battery	N/A	N/A		Y		Y	Y		N/A	N/A	N/A	
	High Ambient Temp	N/A	N/A		Y		Y	Y		N/A	N/A	N/A	
	Door Ajar	/	/		Y		/	/		/	/	/	
Accessories	Caster	Y	Y		Y		Y	Y		N/A	N/A	N/A	
	Foot	Y	Y		Y		Y	Y		N/A	N/A	N/A	
	Porthole	Y	Y		Y		Y	Y		Y	Y	N/A	
	Drawers/Inner Doors	3/-	7/-		6/-		12/-	10/-		/	/	/	
	USB Interface	N/A	N/A		Optional		Optional	Optional		N/A	N/A	N/A	
	Temperature Recorder	N/A	N/A		Optional		Optional	Optional		N/A	N/A	N/A	
Others	Certification	CE	CE	/	CE		CE	CE	CE	CE	CE		

Typical Installation and Application

Biomedical -30°C biomedical freezer: safe and reliable dual-system, intelligent hot gas defrosting, hydrocarbon energy saving



DW-30L1280F

Key Features



Hydrocarbon energy saving: green and environmental protection

Using green and eco-friendly hydrocarbon refrigeration system, based on the principle of zero damage to ozone sphere and zero boost to greenhouse effect, we effectively reduce the energy consumption to 8kW/24H.



Intelligent defrosting: prolong the defrosting cycle, safeguard the stability of storage temperature

The intelligent defrosting is two times less than the traditional defrosting, effectively draws down the temperature fluctuation caused by defrosting during sample storage cycle via intelligently identifying the amount of frost on evaporator.



Dual independent refrigeration systems: higher safety

Auto defrosting system plus constant refrigeration system, successfully solve the industry problem that inside temperature rise sharply when fan cooling refrigerator defrosts; Once one system failed, the other one would reach to -25 °C soon; which double the safety of the sample. With air cooling technology, the inside uniformity can reach ±3°C (±5°C during defrosting period).



Hot gas defrosting technology: eradicate the hidden danger of electric leakage

We apply full-automatic hot gas defrosting technology on the whole machine. Compared with heater wire defrosting technology, it gets rid of the risk of electric leakage due to wire aging, offers you higher efficiency and safety.



Low noise

Optimize system and engine room noise reduction design, noise: 45.4db (220V/50Hz test data)

Product Advantages

- Microcomputer control**
LED digital temperature display with inside temperature accuracy of 0.1°C, while at the same time displaying the voltage and ambient temperature, alarm, AB operating system and defrost level settings.
- Supersized double outer doors**
70mm insulation layer.
- Standard USB port**
Capable of storing more than 15 years of data.
- Safe lock**
Electronic mortise lock design, with NFC clocking-in function (fingerprint optional).
- Casters and feet**
4 omnidirectional casters and 2 level legs, easy to move, lock and level.
- Low noise**
Optimal system and engine noise reduction design, the temperature can cool down to -30°C within 5 hours.
- Heat preservation design of refrigeration unit**
Subtle temperature rise during defrosting.
- Intelligent hot gas defrosting**
Prolongs the defrosting cycle, eradicates the hidden danger of electric leakage.
- 5 shelves**
Equipped with 12 stainless steel shelves of 5 layers, which are adjustable to meet different requirements of users.
- Foam beam design**
Better insulation effect.
- Optional: Blood baskets** (48 units), and the capacity is 900 x 200ml blood bags.
- Bottom strainer drawble design**
Easy to clean.

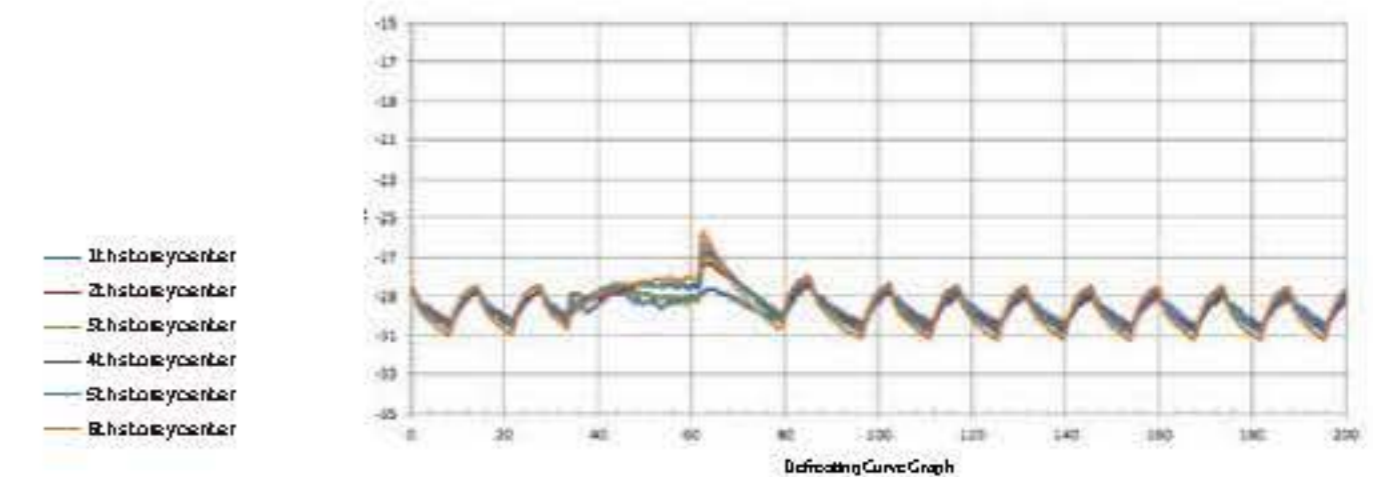
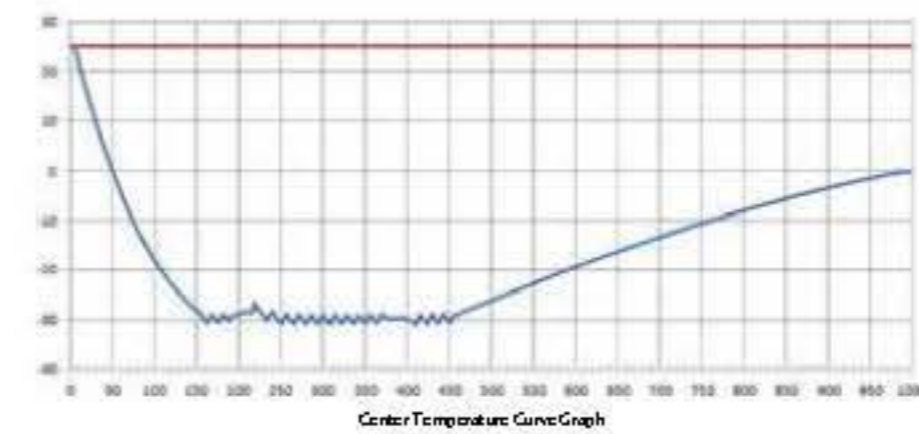

Specifications

Model		DW-30L1280F	
Technical Data	Cabinet Type	Upright	
	Climate Class	N	
	Cooling Type	Forced aircooling	
	Defrost Mode	Automatic defrost	
	Refrigerant	HC	
	Sound Level [dB(A)]	46	
Performance	Cooling Performance [°C]	-30	
	Temp Range [°C]	-10 ~ -30	
Control	Controller	Microprocessor	
	Display	LCD	
Electrical Data	Power Supply [V/Hz]	220 ~ 240/50	
	Power [W]	800	
	Electrical Current [A]	4.5	
Dimensions	Capacity [L/Cu.Ft.]	1280/45.2	
	Net/Gross Weight [approx]	kg	420/480
		lbs	925/1057
	Interior Dimension [W*D*H]	mm	1320*752*1260
		in	52/29.6/49.6
	Exterior Dimension [W*D*H]	mm	1520*1065*1980
		in	59.8/41.9/77.9
Packing Dimension [W*D*H]	mm	1570*1080*2130	
	in	61.8/42.5/83.8	
Container Load [20'/40'/40'H]	6/14/14		
Alarms	High/Low Temperature	Y	
	Remote Alarm	Y	
	Power Failure	Y	
	Sensor Error	Y	
	Low Battery	Y	
	High Ambient Temperature	Y	
	Door Ajar	Y	
Accessories	Castor	Y	
	Sensor Error	Y	
	Porthole	Y	
	Drawers/Inner Doors	12/-	
	Temperature Recorder	/	
	USB Interface	Y	
Other	RS 485	Y	
	Certification	CE	

F suffix - Forced aircooling

Product appearance and specifications are subject to change without notice

Typical Installation and Application

Suitable for sample storage within blood banks, hospitals, disease control centres, research institutes, electronic, chemical and other industries, cryopreservation of plasma, biologics and other products, also suitable for cold tests for components and materials.



DW-30L818BP

Key Features



Energy saving with variable frequency inverter technology

Optimized refrigeration system with a high efficiency inverter compressor to reduce energy consumption.



Excellent temperature uniformity in a large storage space

Features built-in evaporator, large storage space and adjustable shelf, providing faster temperature pulldown and a better temperature uniformity of set point $\pm 3^{\circ}\text{C}$.



Low noise

Sound reduction design lowers the sound level to 37 dB(A) at 220V/50Hz.



Environment Friendly

1) HC refrigeration system contains zero chlorine and fluorine, which is better for the environment.
2) Urethane foam insulation complies with European ROHS regulation.

Product Advantages

Ergonomic Design: document holding compartment for storing size A4 paper and pens.

Optional USB port allows users to download temperature data saved up to 10 years for compliance and auditing purposes.



Double door seals for better insulation performance.



Pressure equalization port for easy door opening.

Microprocessor temperature control: LED displays cabinet temperature with 0.1°C resolution, ambient temperature, and input voltage.



DW-30L818BP

Ergonomic handle design: easy access to storage space, built in lock and padlock features.

Casters and leveling legs for ease of maneuvering and positioning.



Powder coating galvanized interior with large round corner design, corrosion resistance and easy to clean.

Inner door design reduces loss of cold air to improve energy efficiency and stable temperature.

Adjustable shelves made with stainless steel or coated steel.

Microprocessor Control System

- Microprocessor-based temperature control.
- Large LED displays cabinet temperature with 0.1 °C resolution with adjustable temperature setting from -10 °C to -30 °C.
- Cabinet temperature, ambient temperature and voltage are shown on the panel.
- Alarm conditions include high and low temperature, sensor error, power failure, low battery, door ajar and high ambient.
- Alarm modes are audible and flashing lights. Remote alarm terminals are available.
- Battery supports display and alarm system for forty eight hours after power outage.
- Optional features are IoT module, USB port, temperature recorder and NFC swipe card functions.

Insulation

- 70 mm thick insulation.
- Inner doors for better thermal efficiency.

Porthole

- Two standard portholes allow ease of temperature testing.

Security Lock

- Lock is standard. Magnetic lock is optional for added protection and security.

Temperature Recorder

- Optional temperature recorder for temperature recording and compliance.



Typical Performance Characteristics at 25°C ambient

— Ambient Temp.
— Center Temp.

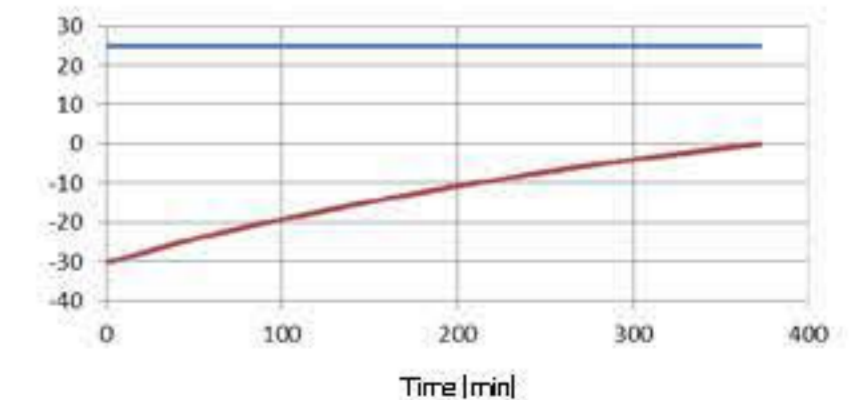
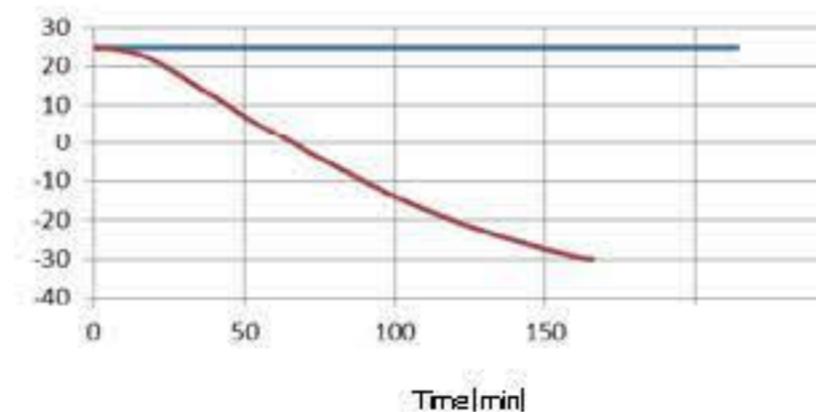

Product Advantages

Easy to clean and corrosion resistant

Electric zinc plate powder sprayed internal liner and large round corner design and coated steel plate exterior design ensure reliable corrosion prevention which is easy to clean.



Specifications

	Model	DW-30L818	DW-30L818BP	
Technical Data	Cabinet Type	Upright	Upright	
	Climate Class	N	N	
	Cooling Type	Direct Cooling	Direct Cooling	
	Defrost Mode	Manual	Manual	
	Refrigerant	HC	HC	
	Sound Level [dB(A)]	44	37 (2.20V/50Hz)	
Performance	Cooling Performance [°C]	-30	-30	
	Temp Range [°C]	-10--30	-10--30	
Control	Controller	Microprocessor	Microprocessor	
	Display	LCD	LED	
Electrical Data	Power Supply [V/Hz]	220-240/50	100-230/50/60	
	Power [W]	380	680	
	Electrical Current [A]	2.8	7.7	
Dimensions	Capacity [L/Cu.Ft]	818/28.8	818/28.8	
	Net/ Gross Weight [approx]	kg	205/235	210/240
		lbs	451.9/518.1	463.0/529.1
	Interior Dimension [W*D*H]	mm	750*755*1460	750*755*1460
		in	29.5*29.7*57.5	29.5/29.7/57.5
	Exterior Dimension [W*D*H]	mm	988*951*1980	988*951*1980
		in	38.9/37.4/78.0	38.9/37.4/78.0
Packing Dimension [W*D*H]	mm	1040*1060*2150	1040*1060*2150	
	in	40.9/41.7/84.6	40.9/41.7/84.6	
Container Load [20'/40'/40'H]		10/22/22	10/22/22	
Alarms	High/ Low Temperature	Y	Y	
	Remote Alarm	Y	Y	
	Power Failure	Y	Y	
	Sensor Error	Y	Y	
	Low Battery	N	Y	
	High Ambient Temperature	Y	Y	
	Door Ajar	Y	Y	
	Castor	Y	Y	
Accessories	Sensor Error	Y	Y	
	Porthole	Y	Y	
	Drawers/ Inner Doors	-/3	-/3	
	Temperature Recorder	Optional	Optional	
	USB Interface	Optional	Optional	
	RS485 Port	Optional	Y	
Other	Certification	CE	CE	

BP suffix - Variable frequency inverter compressor

Product appearance and specifications are subject to change without notice

This freezer is designed for storage of critical and temperature sensitive biological samples, laboratory products and medical products in institutions such as blood banks, hospitals and research laboratories.



Key Features

- Forced air and auto defrost design: -30°C storage temperature with automatic defrost cycles guided by time and temperature, ensure maximum temperature stability and minimize energy use
- High-performance refrigeration system: achieves excellent temperature uniformity with intelligent operation control at -30°C
- Microprocessor control with digital display: 0.1°C control increments, adjustable range of -10°C to -30°C



Door lock and padlock



Backup battery protection



USB



Malfunction Alarms

DW-30L420F



Drawer (Optional)



Microprocessor control panel



Air distribution



Safety

- Alarm system includes audible and visual alerts. Alarms include high and low temperature, sensor error, power failure, door ajar, low battery and high ambient temperature. Remote contacts are standard
- Backup battery provides continuous monitoring and displays the interior temperature for up to 48hrs in the event of a mains power failure
- Standard USB port on DW-30L420F allows users to download temperature data
- Lockable door with padlock for added sample security

Ergonomic Design

- Self-closing door with 90° stay-open feature conserves energy and helps maintain temperature uniformity to protect your valuable samples
- Corrosion-free interior brushed stainless steel liner and exterior coated steel plate
- 5 adjustable stainless steel shelves and optional drawer
- Casters and levelling legs, easy to move and lock

Pull down test at 25°C ambient

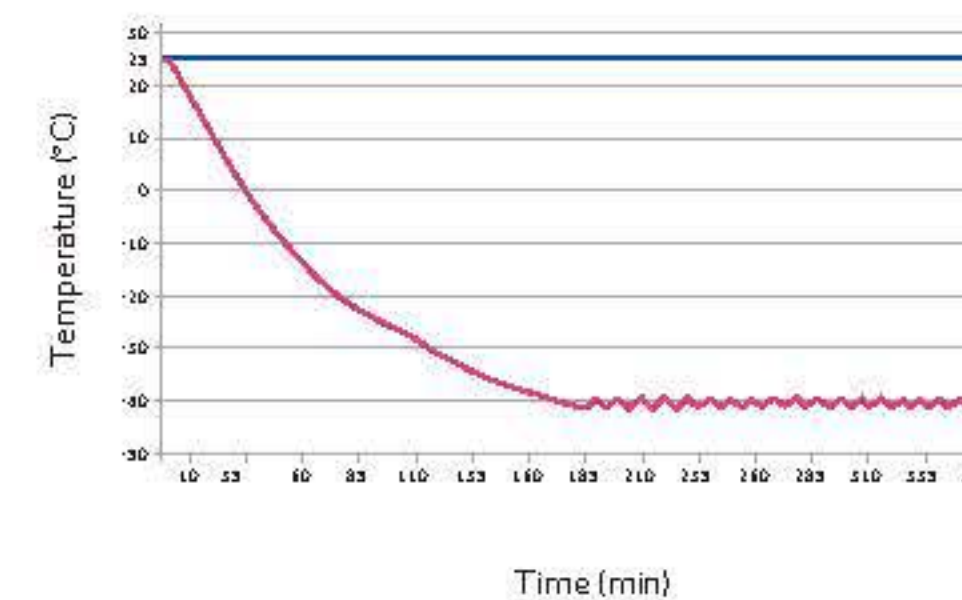

Temperature Uniformity

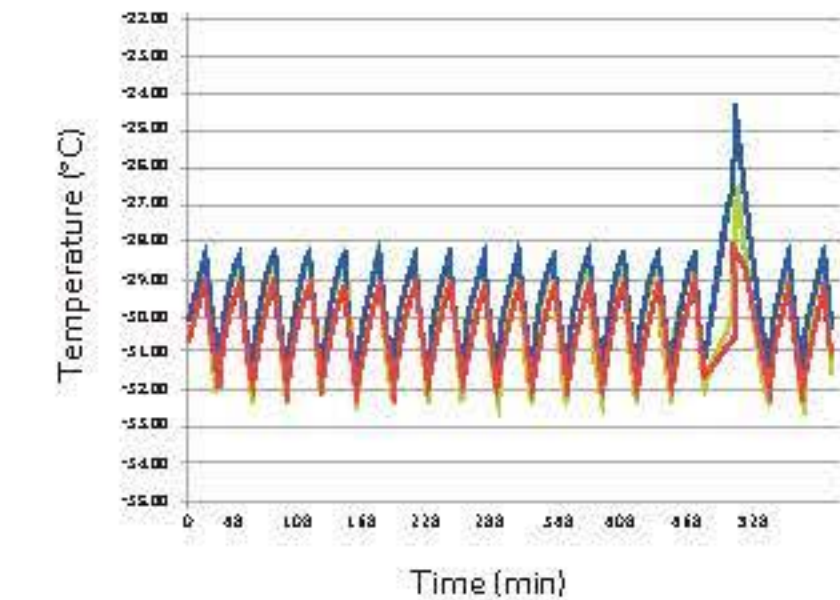

*Freezer set-point -30°C, ambient temperature 25°C

bitstrong Biomedical -30°C biomedical freezer with smart control and energy-saving hydrocarbon refrigeration system for safe and reliable product storage.



DW-30L278



DW-30L508

Application

Biomedical and life science laboratories within blood banks, hospitals, disease control centres and research institutes as well as electronics and chemical industries. Used for cryopreservation of plasma, biological samples and other products and cold tests for components and materials.

Advantages

- High-efficiency and energy-saving compressor and refrigeration system**
 Industrial grade energy-saving compressor and optimized cooling system reduces power consumption by more than 55% compared with older models.
- Superior temperature uniformity**
 Evaporator-shelf design speeds up the cooling process and provides a more uniform temperature distribution. The temperature uniformity at specific points throughout the unit is $\pm 4^{\circ}\text{C}$.
- Green and environmentally friendly**
 Hydrocarbon refrigerant compressor system and use of hydrocarbon refrigerants makes the refrigeration system completely green and environmental friendly. Built with isopentane foam polyurethane insulation, which complies with European RoHS Directive.
- Low sound level**
 Sound-reducing design with optimized system reduces the sound level, smoother operation eliminates high-pitched noise.

Key Features



Microprocessor control system:

- Microprocessor temperature controller, LCD temperature display, display accuracy at 0.1°C .
- Adjustable temperature setting from -10°C to -30°C
- Multiple alarm functions including high temperature alarm, low temperature alarm, sensor failure alarm and power failure alarm
- Sound and flash alarm
- Alarm lasts for more than 24 hours after power failure



Excellent temperature-retaining ability

High efficient insulation and double-sealing design improves temperature performance, energy efficiency and system reliability



Lock

Lock latch and key lock double-lock design provides an extra level of security



Porthole

Porthole design is standard



Recorder

Optional chart temperature recorder available





DW-30L508

DW-30L508 | TYPICAL PERFORMANCE CHARACTERISTICS AT 25°C AMBIENT

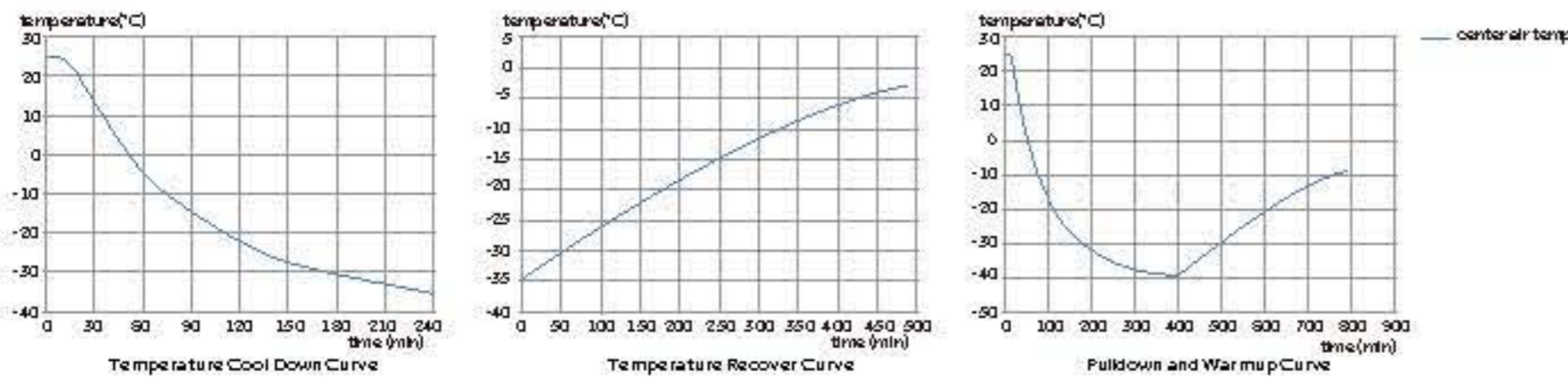

Specifications

	Model	DW-30L420F	DW-30L278	DW-30L508		
Technical Data	Cabinet Type	Upright	Upright	Upright, Double Door		
	Climate Class	4	4	4		
	Cooling Type	Forced air Cooling	Direct Cooling	Direct Cooling		
	Defrost Mode	Automatic Defrost	Manual	Manual		
	Refrigerant	HC	HC	HC		
	Sound Level [dB(A)]	46	40	41	43	
Performance	Cooling Performance [°C]	-30	-30	-30		
	Temperature Range [°C]	-10--30	-10--30	-10--30		
Control	Controller	Microprocessor	Microprocessor	Microprocessor		
	Display	LED	LCD	LCD	LED	
Electrical Data	Power Supply [V/Hz]	220-240/50 208-230/60	220-240/50	220-240/50	115/60	
	Power [W]	460/1000 (Defrost)	330	530	600	
	Electrical Current [A]	4.0/5.8 (Defrost)	2	3	6.5	
Dimensions	Capacity [L/Cu.Ft]	420/14.8	278/9.8	490/17.3		
	Net/Gross Weight [approx]	kg	195/225	115/135	164/200	
		lbs	429.9/496.0	253.7/297.9	361.6/440.9	
	Interior Dimension [W*D*H]	mm	685*610*1028	520*435*1230	685*610*1228	
		in	27.0*24.0*40.5	20.5*17.1*48.4	27.0*24.0*48.3	
	Exterior Dimension [W*D*H]	mm	950*890*1900	745*675*1810	915*810*1860	
		in	37.4*74.4*74.8	29.3*26.6*71.3	36.0*31.9*73.2	
Packing Dimension [W*D*H]	mm	980*905*2040	805*725*1970	980*905*2040		
	in	38.6*36.0*80.3	31.7*28.5*77.6	38.6*35.6*80.3		
Container Load [20"/40"/40"H]		12/24/24	14/28/28	12/24/24		
Alarms	High/Low Temperature	Y	Y	Y	Y	
	Remote Alarm	Y	/	/	Y	
	Power Failure	Y	Y	Y	/	
	Sensor Error	Y	Y	Y	Y	
	Low Battery	Y	/	/	/	
	High Ambient Temperature	Y	/	/	/	
	Door Ajar	Y	/	/	/	
	Caster	Y	Y	Y		
Accessories	Foot	Y	Y	Y		
	Porthole	Y	Y	Y		
	Drawers/Inner Doors	-/3 6 (Optional)/-	6/-	10/-		
	Temperature Recorder	Optional	Optional	Optional		
	USB Interface	Y	/	/		
Others	Certification	CE	CE	CE	UL	

Product appearance and specifications are subject to change without notice

The Haier Biomedical -25°C biomedical freezer maximises storage space. Integrated cold shelf and evaporator design provides maximum refrigeration efficiency.



DW-25L262

Reliability and Key Features

- Chemically stable, HC commercially available and environmentally safe refrigerant
- High density foam insulation for rigidity and stable storage temperature
- Microprocessor control, digital display, adjustable temperature range: -10°C--25°C
- LED digital display for clear observation
- Wide voltage tolerance design with applicable voltage range of 187-242 V/AC

Safety

- Multiple malfunction alarms including high low temperature, sensor error
- Two types of alarm indications: audible buzzing and visible flashing light
- Door lock for storage safety
- Storage drawer

-25°C Biomedical Freezer

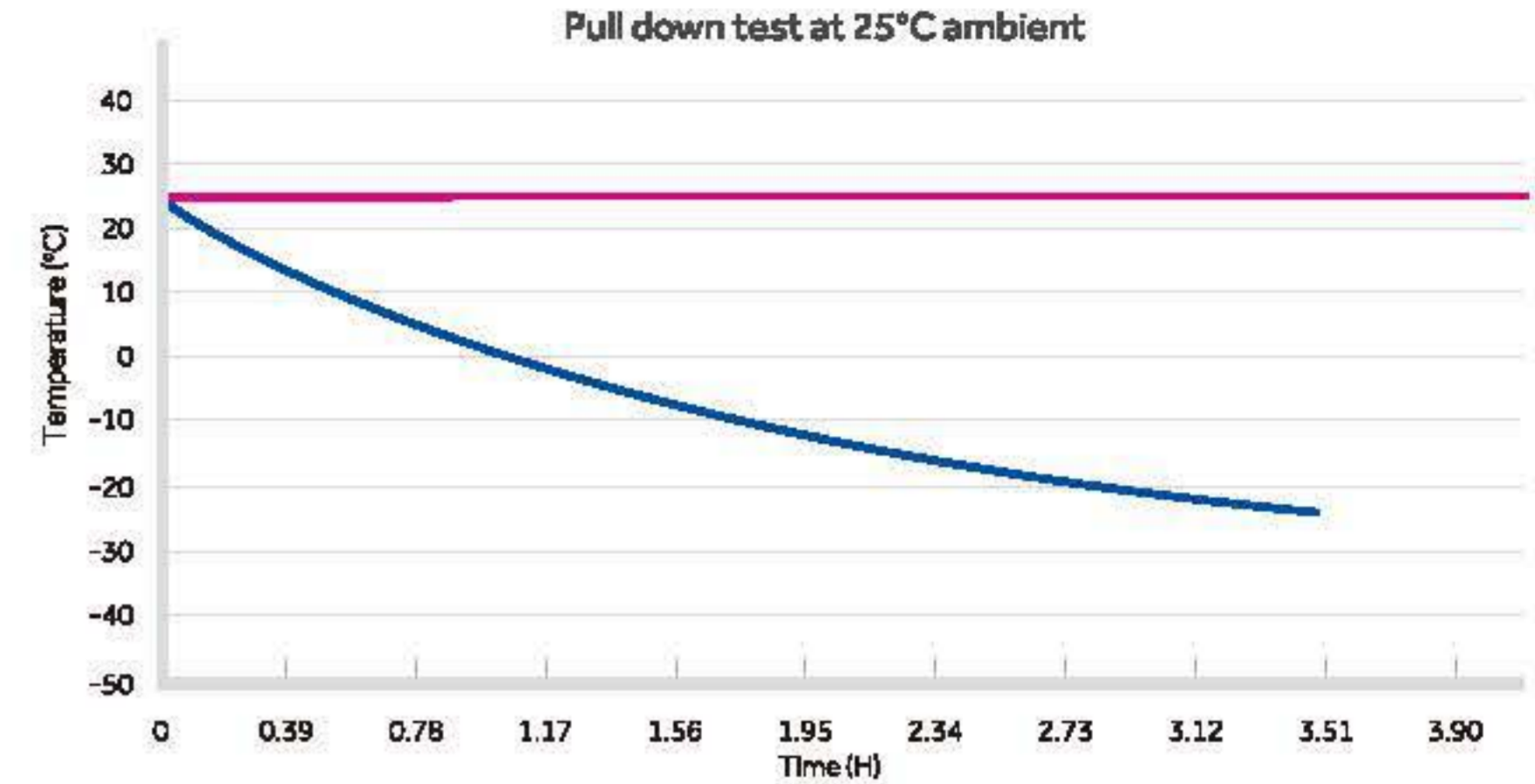

Specifications

	Model	DW-25L92		DW-25L262		
Technical Data	Cabinet Type	Upright		Upright		
	Climate Class	4		4		
	Cooling Type	Direct Cooling		Direct Cooling		
	Defrost Mode	Manual		Manual		
	Refrigerant	HC		HC		
	Sound level [dB(A)]	27	28	34	35	
Performance	Cooling Performance [°C]	-25		-25		
	Temperature Range [°C]	-10--25		-10--25		
Control	Controller	Microprocessor		Microprocessor		
	Display	LED		LED		
Electrical Data	Power Supply [V/Hz]	220-240/50	115/60	220-240/50	115/60	
	Power [W]	77	125	90	135	
	Electrical Current [A]	0.68	1.8	0.96	2.6	
Dimensions	Capacity [L/ Cu.Ft]	92/3.2		262/9.3		
	Net/Gross Weight [approx]	kg	46/51		88/93	
		lbs	101.4/112.4		194.0/205.0	
	Interior Dimensions [W*D*H]	mm	435*410*635		480*465*1430	
		in	17.1*16.1*25.0		18.9*18.3*56.3	
	Exterior Dimensions [W*D*H]	mm	640*610*860		597*635*835	
		in	25.2*24.0*33.9		23.5*25.0*32.9	
Packing Dimensions [W*D*H]	mm	660*700*935		680*690*910		
	in	26.0*27.6*36.8		26.8*27.2*35.8		
Container Load [20/40/40*H]		50/108/108		24/48/48		
Alarms	High/Low Temp	Y	Y	Y	Y	
	Sensor Error	Y	Y	Y	Y	
	Door Ajar	/	Y	/	/	
	Remote Alarm	/	Y	/	/	
Accessories	Drawers	3		7		
Others	Certification	CE	UL	CE	UL	

Product appearance and specifications are subject to change with out notice



**Spark Free
Refrigerator/Freezer**

Typical Installation

Sparkfree refrigerators are installed typically in many different laboratories and research facilities to store chemical or experimental reagents that are flammable, explosive, evaporative or corrosive.



Product Advantages

ATEX II C-T6 E.U. Explosion Proof Certification

Explosion proof features include antistatic liner, gasket, explosion proof fan motor, over current and voltage protection. ATEX II C-T6 explosion proof certification for Haier's laboratory refrigerator ensures safety in your work place.

3-16°C Setting Temperature Range

Smart temperature control system limits the temperature variance within $\pm 3^{\circ}\text{C}$. Adjustable set point for the range of 3°C - 16°C , factory default set temperature is 5°C , controlling the temperature inside the chamber is $2-8^{\circ}\text{C}$.

One-touch Search for Historic Data

The highest and lowest historic temperature data is saved and can be checked with one key stroke.

High Efficiency HC Cooling Technology

The hydrocarbon refrigeration system operates at a much higher efficiency and reduces the energy consumption by about 50 percent.

Spark Free Refrigerator

Ergonomic Design

High Strength Glass Shelves

Tempered glass shelves hold 40 kg of products per shelf.

Low Noise

Noise cancelling technology reduces the sound level to less than 40 dB(A) for a much-improved environment.



Dual Lock Design with Multiple Alarm Systems

A mortise lock is standard on the door. Standard alarms include high and low temperature, door opening, and sensor errors.



Cabinet Structure



Glass Shelf



ATEX Certification Label



Explosion Proof Cabinet/Fan



Application Range

bitstrong spark free refrigerators are ATEX certified in the application range II 3G Ex ic nA II T6, which means the appliances can be found in the whole II zone environment (including II A and II B, II C), a typical environment within many biochemistry laboratories.

Explosive-proof Rating

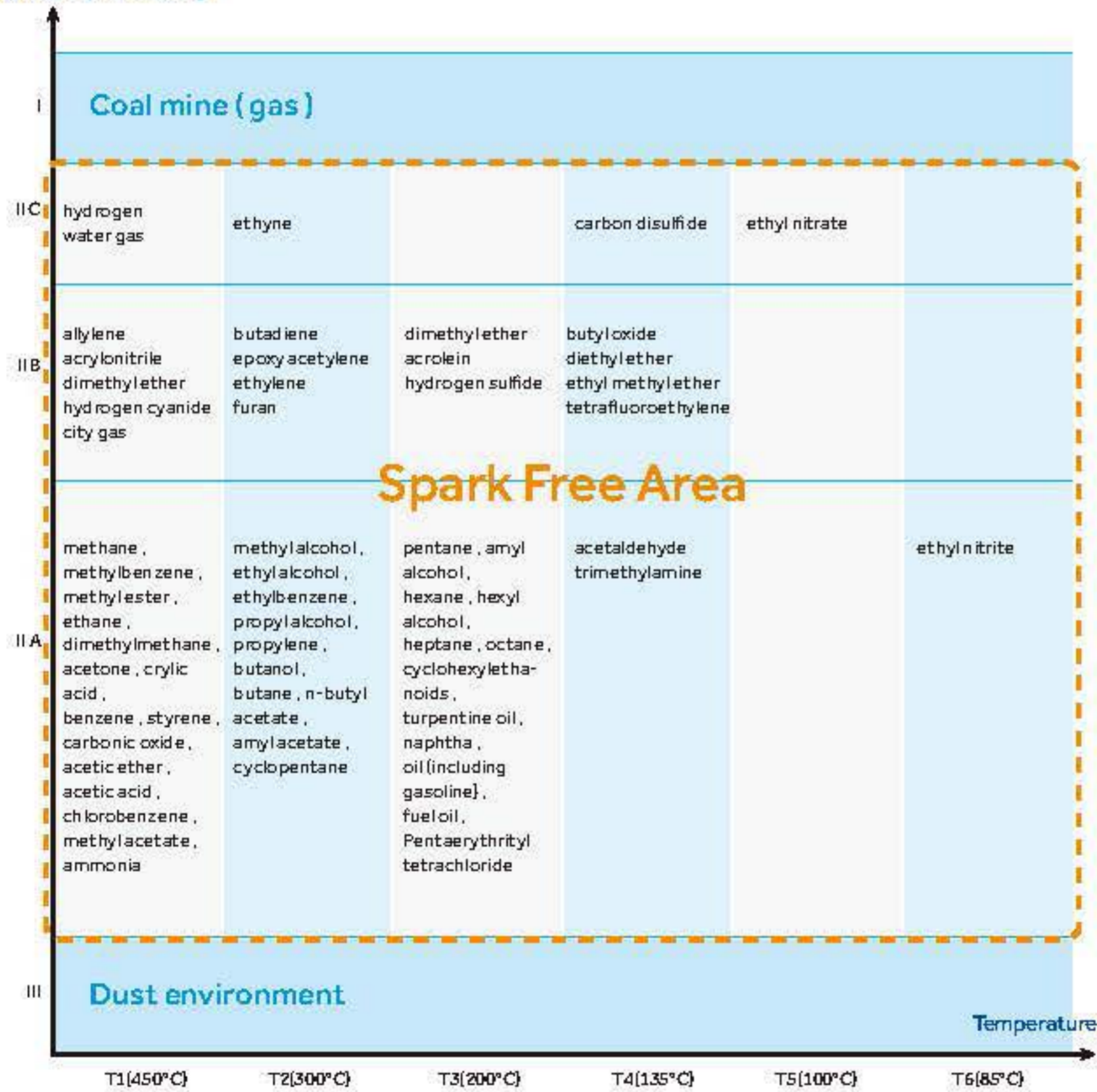

Warning: Do not store open containers of volatile substances in this refrigerator.

Specifications

Model	HLR-118SF	HLR-310SF	HLR-118FL	HLR-310FL
Technical Data	Type: Under-Counter	Upright	Under-Counter	Upright
Climate Class	N	N	N	N
Cooling Type	Forced Air Cooling	Forced Air Cooling	Forced Air Cooling	Forced Air Cooling
Defrost Mode	Auto	Auto	Auto	Auto
Refrigerant	R600a	R600a	R600a	R600a
Sound Level [dB(A)]	40	40	40	40
Performance	Temperature Range [°C]: 3-16°C Adjustable	3-16°C Adjustable	3-16°C Adjustable	3-16°C Adjustable
Ambient Temperature [°C]	16-32°C	16-32°C	16-32°C	16-38°C
Control	Controller: Microprocessor	Microprocessor	Microprocessor	Microprocessor
Display	LED	LED	LED	LED
Electrical Data	Power Supply [V/Hz]: 220-240/50	220-240/50	220-240/50	220-240/50
Power [W]	55	210	55	210
Electrical Current [A]	1.2	1.26	1.2	1.26
Dimensions	Capacity [L/Cu.Ft]: 118/4.2	310/10.9	118/4.2	310/10.9
Net/Gross Weight [approx]	kg	44/49	72/83	44/49
	lbs	97/108	158.7/183	97/108
Interior Dimensions [W*D*H]	mm	515*415*630	560*500*1290	515*415*630
	in	20.3*16.3*24.8	22.0*19.7*50.8	20.3*16.3*24.8
Exterior Dimensions [W*D*H]	mm	597*635*810	605*598*1840	597*635*810
	in	23.5*25*31.9	23.8*23.6*73.6	23.5*25*31.9
Packing Dimensions [W*D*H]	mm	680*690*890	660*670*2020	680*690*890
	in	26.8*27.2*35	26*26.4*79.5	26.8*27.2*35
Container Load [20'/40'/40'H]	48/102/102	27/57/57	48/102/102	27/57/57
Alarms	High/Low Temperature	Y	Y	Y
Power Failure	Optional	Optional	Optional	Optional
Sensor Error	Y	Y	Y	Y
Door Ajar	Y	Y	Y	Y
Remote Alarm	Optional	Optional	Optional	Optional
Accessories	Caster	2	4	2
Foot	2	2	2	2
Shelves/Baskets	2/1	4/0	2/1	4/0
Water Tray	1	1	1	1
Padlock Adapter Kit/Quantity	/	1	/	1
Built-in Key Door Lock/Quantity	1	1	1	1
Others	Certification	CE ATEX	CE ATEX	CE ATEX
Interior Material/Colour	PS Plate/White	PS Plate/White	PS Plate/White	Antistatic PS Plate/Black

Product appearance and specifications are subject to change without notice

Typical Installation

It can be used for safe storage of potentially flammable items and other temperature sensitive samples at low temperatures. Applications found within life science, medical, electronics and chemical industries.



DW-30L278SF



Product Advantages

Explosion Proof Interior

The SF series is composed of a non-anti-static liner, door lining and drawers; the FL series is composed of an anti-static liner, door lining and drawers. Equipped with an overcurrent and overvoltage protection system with all components earthed to ensure static is discharged safely. Certified to ATEX IIC-T6 EU and can be used in zone 2 environments.



DW-25L92FL



DW-30L278SF/FL

Hydrocarbon Energy-saving

- Utilizing a hydrocarbon compressor and hydrocarbon refrigerant resulting in a more eco-friendly refrigeration system
- Cyclo-isopentane foaming polyurethane insulation and manufactured with materials that comply with the European ROHS directive for environmental protection.
- The hydrocarbon energy-saving and high-efficiency compressor results in an optimized refrigeration system which is more energy efficient than older models.

Excellent Temperature Uniformity

An evaporator shelf design is adopted inside the freezer whereby the evaporation plate serves as a shelf, to ensure faster cooling and a more uniform temperature. The temperature uniformity at points throughout the unit is $\pm 4^{\circ}\text{C}$.

Low Noise

Cabinet structure and refrigeration system noise reduction design lowers noise level to less than 40dB(A) and eliminating any harsh high-frequency noises.



Key Features



Microprocessor-controlled system

- Microprocessor electronic thermostat, LCD temperature display to an accuracy of 0.1°C;
- Adjustable set point of between -10~-30°C;
- Alarm functions include a high and low temperature alarm, sensor failure alarm and power failure alarm;
- Audible and visual alarm;
- Display/Alarm is battery backed up for 24 hours in the event of a power failure.



Good thermal insulation

The super-thick insulation layer and removable door gasket design improves the thermal insulation and energy-saving effects to enhance the reliability of the freezer.



Safety lock

Dual-lock design of lock catch and key lock. An external padlock can be added for additional security.



Warning sticker

The SF series adopts the non-anti-static liner and front-operated yellow warning sticker to warn users about safe operation requirements and ensure safe use.



Drawers

The SF series of freezer are provided with six plastic drawers and the FL series are provided with six drawers made of anti-static materials. Each drawer has a warning sticker slot to meet different storage and identification requirements.



Caster

Caster and levelling feet design, easy to move and fix in place.

Specifications

Model	DW-25L92SF	DW-30L278SF	DW-25L92FL	DW-30L278FL		
Technical Data	Cabinet Type	Upright	Upright	Upright	Upright	
	Climate Class	4	4	4	4	
	Cooling Type	Direct Cooling	Direct Cooling	Direct Cooling	Direct Cooling	
	Defrost Mode	Manual	Manual	Manual	Manual	
	Refrigerant	HC	HC	HC	HC	
Performance	Sound Level(dB(A))	27	40	27	40	
	Cooling Performance(°C)	-25	-30	-25	-30	
Control	Temperature Range (°C)	-10~-25	-10~-30	-10~-25	-10~-30	
	Controller	Microprocessor	Microprocessor	Microprocessor	Microprocessor	
Electrical Data	Display	LED	LCD	LED	LCD	
	Power Supply(V/Hz)	220-240/50	220-240/50	220-240/50	220-240/50	
	Power(W)	160	330	160	330	
Dimensions	Electrical Current(A)	0.75	2.0	0.75	2.0	
	Capacity(L/Cu.Ft)	92/3.3	278/9.8	92/3.3	278/9.8	
	Net/Gross Weight(approx)	kg	46/51	115/135	46/51	115/135
		lbs	101/113	254/298	101/113	254/298
	Interior Dimensions(W*D*H)	mm	435*410*635	520*435*1230	435*410*635	520*435*1230
		in	17.1*16.1*25	20.5*17.1*48.4	17.1*16.1*25	20.5*17.1*48.4
	Exterior Dimensions(W*D*H)	mm	597*635*835	745*675*1810	597*635*835	745*675*1810
		in	23.5*25*32.9	29.3*26.6*71.3	23.5*25*32.9	29.3*26.6*71.3
	Packing Dimensions(W*D*H)	mm	680*690*910	805*725*1970	680*690*910	805*725*1970
		in	26.8*27.2*35.8	31.7*28.5*77.6	26.8*27.2*35.8	31.7*28.5*77.6
Container Load (20'/40'/40'H)	48/102/102	23/46/46	48/102/102	23/46/46		
Alarms	High/Low Temperature	Y	Y	Y	Y	
	Remote Alarm	Y	/	Y	/	
	Power Failure	/	Y	/	Y	
	Sensor Error	Y	Y	Y	Y	
	Door Ajar	Y	/	Y	/	
Accessories	Caster	Y	Y	Y	Y	
	Foot	Y	Y	Y	Y	
	Drawers/Inner Doors	3/-	6/-	3/-	6/-	
Others	Certification	CE ATEX	CE ATEX	CE ATEX	CE ATEX	
	Interior Material/Colour	PS Plate/White	PS Plate/Grey	Antistatic PS Plate/Black	Antistatic PS Plate/Black	

Product appearance and specifications are subject to change without notice



Laboratory Refrigerator

Typical Installation

Used to store chemicals, reagents and consumables within laboratories and research facilities.

Product Advantages

Precise Control of Temperature

Adjustable set temperature range is 3°C to 16°C. A smart temperature control system keeps the internal temperature variation within ±3°C inside the chamber.

High Efficiency HC Cooling Technology

The hydrocarbon refrigeration system operates at a much higher efficiency and reduces the energy consumption by about 50 percent.

Ergonomic Design

One-touch search for historic data

The highest and lowest historic temperature data is saved and can be checked with one key stroke.

Low Noise

Noise cancelling technology reduces the sound level to less than 40 dB(A) for an improved working environment.

Automatic Door Closing Function



Cabinet Structure



Glass Shelf



Fan/Interior Light



Display Board



High Strength Glass Shelves

Tempered glass shelves hold 20 kg of products per shelf.

Dual lock design with multiple alarm systems

A mortise lock is standard on the door with option to add a padlock for additional security. Standard alarms include high and low temperature, door opening, and sensor errors.

Laboratory Refrigerator

Specifications

Model		HLR-198F	HLR-310F	
Technical Data	Type	Upright	Upright	
	Climate Class	N	N	
	Cooling Type	Forced Air Cooling	Forced Air Cooling	
	Defrost Mode	Auto	Auto	
	Refrigerant	R600a	R600a	
	Sound Level [dB(A)]	37	40	
Performance	Temperature Range [°C]	3-16 Adjustable	3-16 Adjustable	
	Ambient Temperature [°C]	16-32	16-32	
Control	Controller	Microprocessor	Microprocessor	
	Display	LED	LED	
Electrical Data	Power Supply [V/Hz]	220-240/50	220-240/50	
	Power [W]	135	225	
	Electrical Current [A]	1	1.6	
Dimensions	Capacity [L/Cu.Ft.]	198/7.0	310/10.9	
	Net/Gross Weight [approx]	kg	57/66	72/83
		lbs	97/108	158.7/183
	Interior Dimensions [W*D*H]	mm	455*445*900	560*500*1290
		in	18.0*17.5*35.5	22.0*19.7*50.8
	Exterior Dimensions [W*D*H]	mm	535*570*1530	605*598*1840
		in	21.1*22.5*60.3	23.8*23.6*73.6
	Packing Dimensions [W*D*H]	mm	595*640*1660	660*670*1920
in		23.4*25.2*65.4	26.0*26.4*75.6	
Container Load [20"/40"/40"H]		48/102/102	27/57/57	
Alarms	High/Low Temperature	Y	Y	
	Sensor Error	Y	Y	
	Door Ajar	Y	Y	
Accessories	Caster	4	4	
	Foot	2	2	
	Porthole	Y	Y	
	Shelves	4	4	
Temperature Setting Mode	Password Protection	Password Protection		
Temperature Sensor	1 Resistance Thermometer	1 Resistance Thermometer		
Power Consumption (kWh/24h)	0.95	1.05		
Certification	CE	CE		

Product appearance and specifications are subject to change without notice.

Application

Heating applications include warming of blood, blood products, liquid medicine, nutrient solution, rinsing liquid and physiological saline. Installations can be found in operating rooms, ICU, emergency rooms, wards and other related areas.

Product Features

- Fast heating speed: variable power PTC heating module with fast heating speed and energy saving.
- UV sterilization: UV light sterilization in the cabinet with a variety of optional sterilization methods for effective prevention of possible contamination.
- Multiple overheat protections: electronic control + mechanical temperature control + overheat protection, multiple temperature control to ensure heating safety.
- Environmentally friendly: no compressor or external fan, extremely quiet with no disturbance to the airflow in the operating room and no effect on temperature, reduces risks of cross-contamination.

Product Advantages

- Fast and efficient heating.
- Standard UV sterilization for effective sterilization and other sterilization options available.
- Multiple over heating protections to ensure product viability.
- Two-sensor.

Ergonomic Design

- Extremely low noise level just 30 dB.
- Large and clear 7-inch LCD touch screen.
- Easy to clean stainless steel interior and flat external surfaces.
- Multiple alarms for over-heating protection.



Internal Structure



7 Inch LCD Screen



UV Sterilization Lamp



Stainless Steel Partition

Specifications

Model		HYR-111	HYR-351	
Technical Data	Cabinet Type	Upright, one glass door	Upright, one glass door	
	Climate Class	SN	SN	
	Warming Type	Forced air warming	Forced air warming	
	Sound Level [dB(A)]	42	42	
Performance	Temperature Range [°C]	26°C-50°C, above ambient temperature	26°C-50°C, above ambient temperature	
Control	Controller	Microprocessor	Microprocessor	
	Display	LCD Touch Screen	LCD Touch Screen	
Electrical Data	Power Supply [V/Hz]	220/50	220/50	
	Power [W]	130	360	
Dimensions	Capacity [L/Cu. Ft.]	111/3.9	351/12.39	
	Net/Gross Weight [approx]	kg	58/68	108/118
		lbs	127.6/149.6	237.6/259.6
	Interior Dimensions [W*D*H]	mm	477*528*462	477*486*1402
		in	18.67*20.67*18.1	18.68*19*54.89
	Exterior Dimensions [W*D*H]	mm	597*682*833	597*682*1813
		in	23.37*26.7*32.61	23.37*26.7*70.98
	Packing Dimensions [W*D*H]	mm	680*742*913	680*742*1893
in		26.6*29.1*35.7	26.6*29.1*74.1	
	Container load [20'/40'/40'H]	24/48/48	24/48/48	
Alarms	High/Low Temperature	Y	Y	
	Sensor Error	Y	Y	
	Door Ajar	Y	Y	
Accessories	Caster	Y	Y	
	Foot	Y	Y	
	Porthole	Y	Y	
	Shelves	Y	Y	

Product appearance and specifications are subject to change without notice

Pharmacy Refrigerator

Main Application

This product is designed to store blood plasma, biological products, vaccines, medicines and chemical reagents.



HYCD-469



Temperature Control



Security Guaranteed



Variable Frequency Hydrocarbon Refrigeration System



Data Storage

Combined Refrigerator and Freezer

Key Features

Temperature Control

- Refrigerator temperature ranges from 2°C to 8°C.
- Freezer temperature ranges adjustable from -10°C to -40°C.
- Microprocessor temperature control accuracy 0.1°C (refrigerator) and 1°C (freezer).

Safety

- Separate doors for refrigerator and freezer with independent lock catches, dual padlocks available to ensure product safety.
- Multiple alarm functions including high or low temperature, sensor error, high ambient temp, power failure and remote alarm.
- Two types of alarm indications: audible buzzer and visible flashing light.

Refrigerator System

- Refrigerator and freezer have independently controlled variable frequency refrigeration systems, standalone displays as well as separate on and off controls.
- Robust compressor system operating with environmentally friendly hydrocarbon refrigerant.
- Refrigerator with high quality and high efficiency cooling fan provides better temperature uniformity and stability.

Ergonomic Design

- Large LED screen display for excellent user interface experience.
- USB port automatically saves temperature data for up to 10 years for convenient inquiry and record keeping.
- Optional printer to simultaneously print out temperatures of the refrigerator and the freezer.
- Four casters and two levelling legs design for ease of maneuvering.

Specifications

		Model	HYCD-469			Model	HYCD-469	
Technical Data	Cabinet Type	Upright		Dimensions	Exterior Dimensions (W*D*H)	mm	738*854*1975	
	Climate Class	N			in	29.1*32.8*77.8		
	Cooling Type	Refrigerator: Forced air cooling Freezer: Direct cooling			Packing Dimensions (W*D*H)	mm	800*875*2100	
	Defrost Mode	Refrigerator: Auto Freezer: Manual			in	31.5*34.4*82.7		
	Refrigerant	HC			Container bad (20/40/40H)	14/30/30		
	Sound Level(dB(A))	45			Alarms	High/Low Temperature	Y	
Performance	Cooling performance (°C)	Freezer: -40		Remote Alarm		Y		
	Temperature Range (°C)	Refrigerator 2-8 Freezer -10~-40		Power Failure		Y		
Control	Controller	Micro processor		Sensor Error		Y		
	Display	LED		Low Battery	Y			
Electrical Data	Power Supply (V/Hz)	220-240/50/60		High Ambient Temp.	Y			
	Power (W)	580		Accessories	Caster	Y		
	Electrical Current (A)	3			Foot	Y		
Dimensions	Capacity (L/Cu.Ft)	Refrigerator: 269/9.5 Freezer: 200/7.1			Porthole	Y		
	Net/Gross Weight (approx)	kg	176/207	Shelves/Drawers	Refrigerator: 3/0 Freezer: 3/0			
		lbs	388.0/456.4	USB Interface	Y			
	Interior Dimensions (W*D*H)	mm	Refrigerator: 593*585*800 Freezer: 553*545*680		Others	Certification	CE	
		in	Refrigerator: 23.3*23.0*31.5 Freezer: 21.8*21.5*26.0					



HYCD-282



HYCD-282A



Combined Refrigerator and Freezer

Excellent Performance

- Refrigerator compartment temperature range: 2°C to 8°C
- Adjustable temperature range for freezer compartment: -20°C to -40°C

Separately Controlled Refrigerator and Freezer

- USB port for data download
- Capable of recording temperature data for up to ten years
- Independent display for refrigerator and freezer sections
- Adjustable shelving in refrigerator and freezer has drawers
- Multiple alarms to detect malfunctions

Specifications

Model	HYCD-282	HYCD-282A	
Cabinet Type	Upright	Upright	
Climate Class	N	N	
Cooling Type	Refrigerator: Forced Air Cooling	Refrigerator: Forced Air Cooling	
	Freezer: Direct Cooling	Freezer: Direct Cooling	
Defrost Mode	Refrigerator: Auto Freezer: Manual	Refrigerator: Auto Freezer: Manual	
Refrigerant	CFC-Free	CFC-Free	
Sound Level [dB(A)]	43	43	
Cooling Performance [°C]	Freezer: -40	Freezer: -40	
	Temperature Range [°C]	2-8/-20--40	2-8/-20--40
Control	Controller	Microprocessor	
	Display	LED	
Electrical Data	Power Supply [V/Hz]	220-240/50	208-230/60
	Power [W]	400	400
	Electrical Current [A]	2.8	2.8
Capacity [L/ Cu.Ft.]	Refrigerator: 185/6.5	Refrigerator: 185/6.5	
	Freezer: 97/3.4	Freezer: 97/3.4	
Net/Gross Weight [approx]	kg	145/160	
	lbs	320.0/352.7	
Interior Dimensions [W*D*H]	mm	Refrigerator: 605*510*720 Freezer: 515*465*440	Refrigerator: 605*510*720 Freezer: 515*465*440
	in	Refrigerator: 23.8*20.0*28.3 Freezer: 20.3*18.3*17.3	Refrigerator: 23.8*20.0*28.3 Freezer: 20.3*18.3*17.3
	mm	736*660*1810	736*660*1810
	in	29.0*26.0*71.3	29.0*26.0*71.3
Packing Dimensions [W*D*H]	mm	775*720*1930	775*720*1930
	in	30.5*28.3*76	30.5*28.3*76
Container Load [20'/40'/40'H]		21/45/45	21/45/45
Alarms	High/Low Temperature	Y	Y
	Remote Alarm	Y	Y
	Power Failure	Y	Y
	Sensor Error	Y	Y
	Low Battery	Y	Y
	High Ambient Temp	Y	Y
Accessories	Caster	Y	Y
	Foot	Y	Y
	Porthole	Y	Y
	Shelves/Drawers	Refrigerator: 3/1 Freezer: 0/2	Refrigerator: 3/1 Freezer: 0/2
	USB Interface	Y	Y
Others	Certification	CE	CE /

Product appearance and specifications are subject to change without notice

Smart Management of Reagents Starts with IoT Technology

From manufacturer to patients, the entire process is automatically and smartly controlled.



HYC-390R



Smart IoT system means simple, precise and effective reagent storage management

Automatic management of reagents is a reality with the utilization of the RFID based smart IoT management system



Smart RFID label



Smart RFID shelf



Industrial-grade IoT network module group



Secure, authorized access management

NFC authorized management system is traceable



Statistical analysis of data and precise verification for compliance

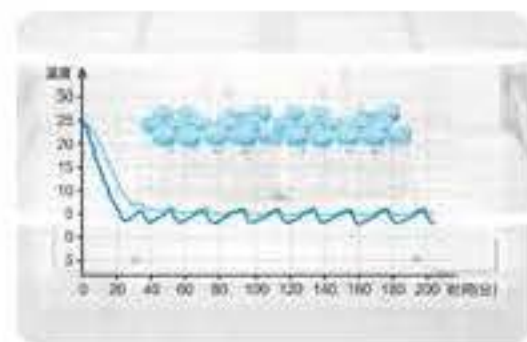

Precise temperature control for ultimate safety of test reagents

2°C- 8°C storage temperature and real time monitoring of cabinet temperature



Smart alerts for maintenance and product management

Smart alarm and alerts for abnormal temperature, low storage level alerts, deadline for clinical trials

RFID Refrigerator



Manpower savings

Smart process control improves accuracy and efficiency, saving manpower for reagent management.



Optimized procurement process

reduces waste

Accurately and timely control of reagent usage. Make intelligent procurement decisions to reduce shortage and reduce inventory.



Rigorous reagent management to reduce risk

Constant temperature for reagent storage. Automatically trigger temperature alarms when fridge reaches critical temperature, ensuring safety of reagent usage.

Specifications

Model		HYC-390R	
Technical Data	Cabinet Type	Upright, single door	
	Climate Class	N	
	Cooling Type	Forced air cooling	
	Defrost Mode	Auto	
	Refrigerant	HC	
	Sound level [dB(A)]	43	
Performance	Cooling performance [°C]	±3	
	Temperature Range [°C]	2-8°C	
Control	Controller	Microprocessor	
	Display	LED	
Electrical Data	Power Supply [V/Hz]	208-230/50/60	
	Power [W]	225	
	Electrical Current [A]	1.2	
Dimensions	Capacity [L/Cu.Ft]	390/ 13.77	
	Net/ Gross Weight [approx]	kg	116/ 139
		lbs	255.73/ 306.44
	Interior Dimensions [W*D*H]	mm	530*555*1380
		in	20.9*21.9*54.3
	Exterior Dimensions [W*D*H]	mm	720*710*1965
		in	28.3*28*77.4
	Packing Dimensions [W*D*H]	mm	792*790*2110
in		31.2*31*82.9	
Container load [20'/40'/ 40'H]		14/45/45	
Alarms	High/Low Temperature	Y	
	Remote Alarm	Y	
	Power Failure	Y	
	Sensor Error	Y	
	Low Battery	Y	
	Door Ajar	Y	
	Caster	Y	
Accessories	Foot	Y	
	Porthole	Y	
	Shelves	5	
Others	Certification	CE	

R suffix - RFID with IoT model for reagent management

Product appearance and specifications are subject to change without notice

Pharmacy Refrigerator with Thermoelectric Cooler (TEC) Technology

The refrigerator can be used to store vaccines, medicines and laboratory products at 2°C to 8°C temperature range in pharmaceutical companies, laboratories, clinics, and hospitals.



HYC-51BF



With TEC technology for super low noise and minimum vibration

- Military grade TEC refrigeration technology (also called a Peltier device)
- Low noise DC fan
- Less than 35dB(A) sound level



Multi temperature protection

- Air temperature sensor for control
- Display sensor for displaying the actual temperature
- Overtemp or high-end temperature sensor to protect TEC module for a service life of more than 10 years



Microprocessor temperature control for 2°C to 8°C

- Forced air cooling with $\pm 1^\circ\text{C}$ temperature uniformity and display accuracy of 0.1°C
- Maximum power for rapid temperature pull-down

Safer by Design

Theory of Operation: Thermoelectric cooling uses the Peltier effect to create a heat flux at the junction of two different types of materials. The cooling power is controlled by pulsing signals to TEC module for tight temperature control of $\pm 1^\circ\text{C}$.



The Advantage of Compressor Free Refrigerator

TEC Technology	VS	Conventional Compressor
 <ul style="list-style-type: none"> • Sustainable & non-toxic refrigeration • Energy efficient and low waste heat • No pumps or motors for quiet operation • No moving/mechanical parts for improved reliability and longevity • Compact design allows for more storage capacity • Lab & Clean room ready dust-free operation 		 <ul style="list-style-type: none"> • Refrigerant required • Less energy efficient • Loud producing motors and compressors • Moving mechanical parts • Larger footprint, demands more valuable space • Expensive filtration required



Power Protection Switch and Removable Power Cord

- Dual safety protections
- Power cord plug accessible on exterior of unit
- Suitable for on and under counter installation
- Universal power supply 220V/115V at 50/60Hz



Frost Free Cooling Fins on TE Module

- Defrost process initiated after accumulated run hours
- Temperature does not exceed 7°C during defrost process



Natural Evaporation of Condensate

- Interior water is drained through a small hole into a stainless steel catch box. Condensate water is evaporated by warm air flow



Self-closing Doors

- Door stays opened at 90 degree
- Door automatically swings closed at less than 90 degree to reduce moisture infiltration
- Tested to 100,000 times door opening and closing



LED Lighting

- Led lights illuminate interior



Removable Trays with ABS Material

- Manufactured using chemical and thermally stable ABS material
- Adjustable three-tray design
- Each tray holds thirty 50*50*50 mm storage boxes, totalling 150 boxes
- Trays designed for over 500,000 movements
- Weight limit at 100 kg/sq. m



Low noise DC fan, sound level less than 35dB (A)

Typical Performance Characteristics at 25°C Ambient

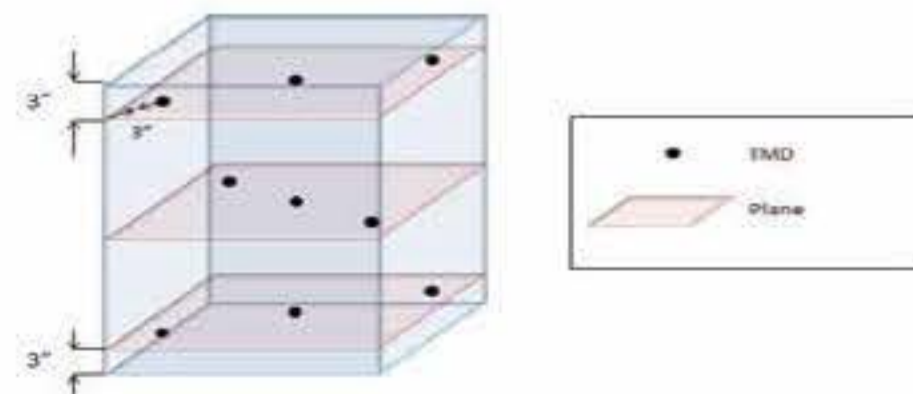
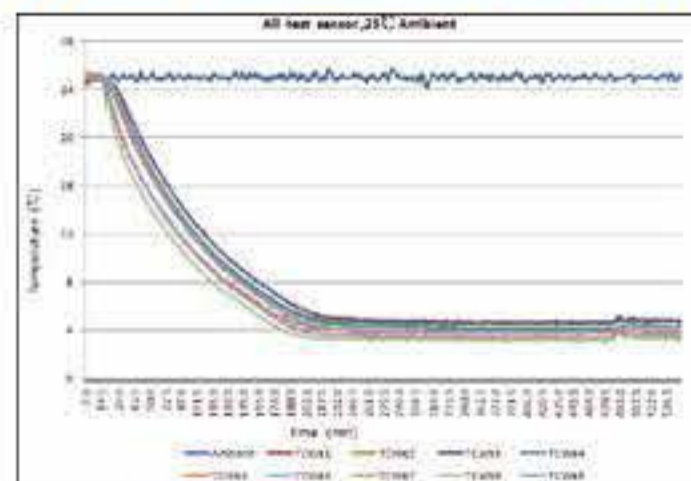

Specifications

Model		HYC-51BF	
Technical Data	Cabinet Type	Upright	
	Climate Class	N	
	Cooling Type	Force Air Cooling	
	Sound Level [dB(A)]	34	
Performance	Cooling Performance [°C]	±2	
	Temp Range [°C]	2-8	
Control	Controller	Microprocessor	
	Display	LCD	
	LCD Size [in]	7	
Electrical Data	Power Supply [V/Hz]	115/60	220-240/50
	Power Input [W]	165	
	Rated Current [A]	1.5	0.8
Dimensions	Net/Gross Weight [approx]	kg	50/57
		lbs	110.3/125.8
	Interior Dimensions [W*D*H]	mm	380*300*470
		in	14.96*11.81*18.5
	Exterior Dimensions [W*D*H]	mm	525*565*720
		in	20.7*22.2*28.3
Packing Dimensions [W*D*H]	mm	550*600*883	
	in	21.7*23.6*34.8	
Container Load [20'/40'/40'H]		72/152/152	
Alarms	High/Low Temp	Y	
	Sensor Error	Y	
	Door Ajar	Y	
	Alarm Mode	Audible Buzzing and Alarm Window	
Accessories	Level Leg	4	
	Tray	3	
	Data Log	USB	
Others	Certification	UL	CE

Product appearance and specifications are subject to change without notice

Pharmacy Refrigerator

Advanced Pharmacy Refrigerator with Touchscreen



HYC-1099TF

HYC-509T

HYC-1099T

HYC-509TF

Product Advantages



Intelligent and Interactive Touchscreen Control

- An intelligent, high definition liquid crystal touch screen control system, allows users to view temperature graphs, operation status, events and alarm records



Data Storage

- Standard USB, optional printer, capable of storing 10 years' temperature data, historical data can be checked and traced



Secure Access and Authorized Management

- NFC authority system works with a magnetic lock system to ensure product safety. In addition, access to unit and stored products is traceable
- Finger print module is optional for additional safety

Pharmacy Refrigerator

Advanced Pharmacy Refrigerator with LED Display



HYC-1099F

HYC-509

HYC-1099

HYC-509F

Product Advantages



Precise Temperature Control and Reliable Operation

- Advanced control system
- Six sensors
- High efficiency air flow system
- Precise temperature control
- Uniform temperature distribution
- VFD driven compressor
- High-efficiency fan motor



Multiple Features for Sample Security And Protection

- Audible buzzer and visual flashing lights for alarm system as standard
- Alarm system includes door ajar, temperature, sensor malfunction, battery, loss of power and clogged condenser
- Remote alarm contact terminals as standard
- Supplied with mechanical lock as standard, there is an optional magnetic lock for added product safety



Environmentally Friendly Refrigeration

- R600a Hydrocarbon refrigeration system does not have any negative impacts of the ozone layer, with zero global warming effect

Specifications

Model		HYC-509	HYC-509F	HYC-509T	HYC-509TF	HYC-1099	HYC-1099F	HYC-1099T	HYC-1099TF	
Technical Data	Cabinet Type	Upright, single glass door	Upright, single solid door	Upright, single glass door	Upright, single solid door	Upright, double glass door	Upright, double solid door	Upright, double glass door	Upright, double solid door	
	Climate Class	N	N	N	N	N	N	N	N	
	Cooling Type	Forced air cooling	Forced air cooling	Forced air cooling	Forced air cooling	Forced air cooling	Forced air cooling	Forced air cooling	Forced air cooling	
	Defrost Mode	Auto	Auto	Auto	Auto	Auto	Auto	Auto	Auto	
	Refrigerant	HC	HC	HC	HC	HC	HC	HC	HC	
	Sound Level (dB(A))	40	40	40	40	43	43	43	43	
Performance	Temperature Range (°C)	2-8	2-8	2-8	2-8	2-8	2-8	2-8	2-8	
Control	Controller	Microprocessor	Microprocessor	Microprocessor	Microprocessor	Microprocessor	Microprocessor	Microprocessor	Microprocessor	
	Display	LED	LED	Touch	Touch	LED	LED	Touch	Touch	
Electrical Data	Power Supply (V/Hz)	208-230/50/60	208-230/50/60	208-230/50/60	208-230/50/60	208-230/50/60	208-230/50/60	208-230/50/60	208-230/50/60	
	Power (W)	370	315	370	315	470	440	470	440	
	Electrical Current (A)	1.85	1.75	1.85	1.75	2.5	2.25	2.5	2.25	
Dimensions	Capacity (L/Cu.Ft)	509/17.97	509/17.97	509/17.97	509/17.97	1099/38.5	1099/38.5	1099/38.5	1099/38.5	
	Net/Gross Weight (approx)	kg	180/215	175/210	180/215	175/210	340/400	330/390	340/400	330/390
		lbs	396/473	385/462	396/473	385/462	748/1000	726/858	748/1000	726/858
	Interior Dimensions (W*D*H)	mm	593*585*1500	593*585*1500	593*585*1500	593*585*1500	1295*585*1500	1295*585*1500	1295*585*1500	1295*585*1500
		in	23.21*22.9*58.8	23.21*22.9*58.8	23.21*22.9*58.8	23.21*22.9*58.8	50.7*22.9*58.8	50.7*22.9*58.8	50.7*22.9*58.8	50.7*22.9*58.8
	Exterior Dimensions (W*D*H)	mm	693*813*1981	693*813*1981	693*813*1981	693*813*1981	1395*813*1981	1395*813*1981	1395*813*1981	1395*813*1981
		in	27.1*31.9*77.7	27.1*31.9*77.7	27.1*31.9*77.7	27.1*31.9*77.7	54.7*31.9*77.7	54.7*31.9*77.7	54.7*31.9*77.7	54.7*31.9*77.7
Packing Dimensions (W*D*H)	mm	800*875*2100	800*875*2100	800*875*2100	800*875*2100	1525*900*2100	1525*900*2100	1525*900*2100	1525*900*2100	
	in	31.3*34.3*82.3	31.3*34.3*82.3	31.3*34.3*82.3	31.3*34.3*82.3	59.8*35.3*82.3	59.8*35.3*82.3	59.8*35.3*82.3	59.8*35.3*82.3	
	Container Load (20'/40'/40'H)	12/24/24	12/24/24	12/24/24	12/24/24	6/12/12	6/12/12	6/12/12	6/12/12	
Functions	High/Low Temperature	Y	Y	Y	Y	Y	Y	Y	Y	
	Remote Alarm	Y	Y	Y	Y	Y	Y	Y	Y	
	Power Failure	Y	Y	Y	Y	Y	Y	Y	Y	
	Sensor Error	Y	Y	Y	Y	Y	Y	Y	Y	
	Low Battery	Y	Y	Y	Y	Y	Y	Y	Y	
	Door Ajar	Y	Y	Y	Y	Y	Y	Y	Y	
Accessories	Caster	Y	Y	Y	Y	Y	Y	Y	Y	
	Foot	Y	Y	Y	Y	Y	Y	Y	Y	
	Porthole	Y	Y	Y	Y	Y	Y	Y	Y	
	Shelves/Drawers	Y/Optional	Y/Optional	Y/Optional	Y/Optional	Y/Optional	Y/Optional	Y/Optional	Y/Optional	
	USB Interface	Y	Y	Y	Y	Y	Y	Y	Y	
Others	Certification	CE	CE	CE	CE	CE	CE	CE	CE	

T suffix - Advanced with touchscreen.
Product appearance and specifications are subject to change without notice.

The bitstrong pharmacy refrigerators are suitable for pharmacies, drug stores, pharmaceutical companies, hospitals, clinics and other pharmaceutical storage areas such as storage and logistics.



HYC-1378

Durable and Reliable - Key Features

- Energy efficient hydrocarbon (HC) refrigeration system
- Permanently lubricated cooling fan for safety and longevity
- Forced-air cooling with optimized air distribution system designed to achieve maximum temperature uniformity and stability
- Optimized refrigeration system design for more effective cooling and speedy recovery
- Temperature variation within $\pm 3^{\circ}\text{C}$
- Chamber temperature range $2\text{--}8^{\circ}\text{C}$
- Microprocessor control with large digital display. Adjustable temperature with an increment of 0.1°C
- Wide voltage tolerance suitable for regions with an unstable voltage supply
- Designed for ambient temperature $10^{\circ}\text{C}\text{--}32^{\circ}\text{C}$ with humidity below 85%

Safety

- Equipped with a complete temperature alarm system featuring audible buzzer and visible flashing light
- Capable of alerting failures due to high or low temperature, sensor error, door ajar, remote alarm, power failure and low battery

Ergonomic Design

- Optimized space utilization design with multi-level and adjustable shelf height to accommodate the different storage requirements of varied sized pharmaceutical products.
- Safety lock to prevent unauthorized access
- Caster design and levelling feet
- Interior light

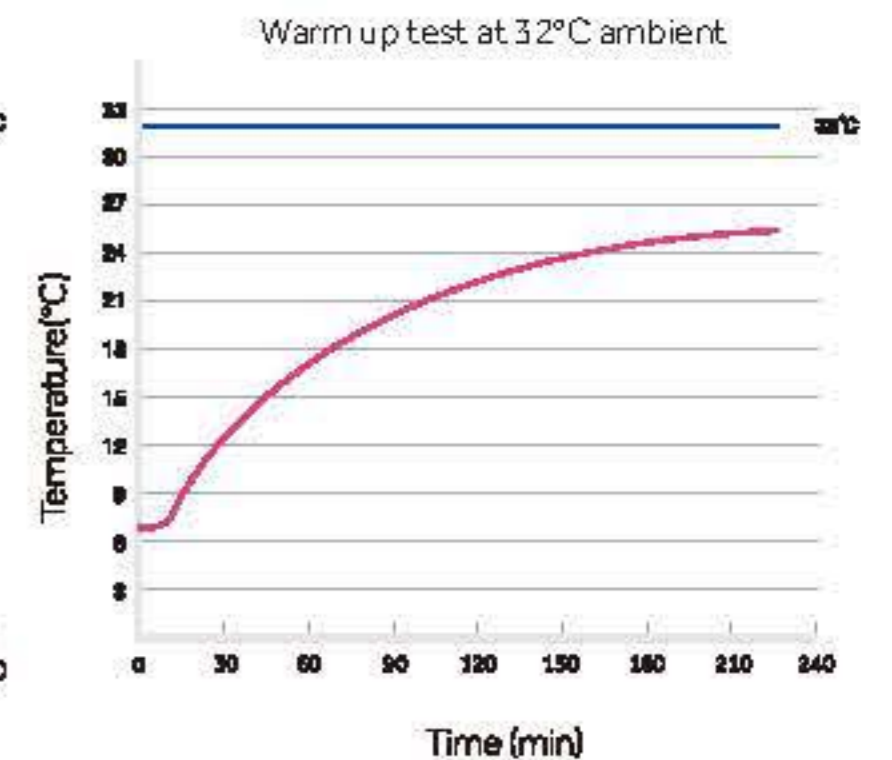
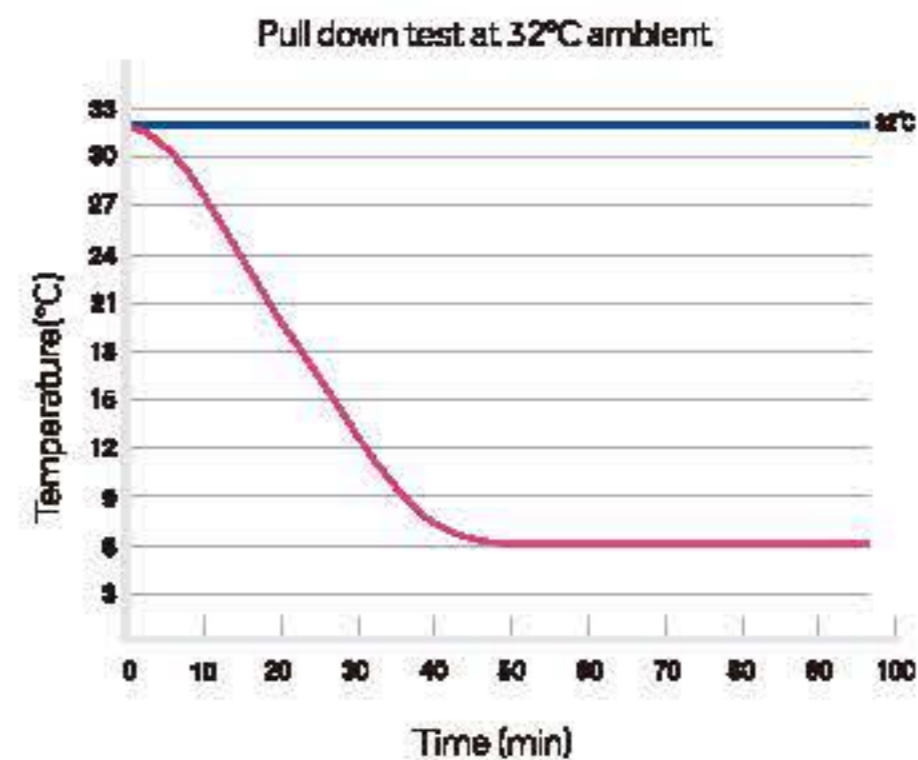

New and improved bitstrong pharmacy refrigerators now offer an improved temperature profile and more user-friendly control features.



Technical Advantages

- Accurate temperature control maintains 2°C to 8°C throughout the unit with an adjustable increment at 0.1°C
- Improved user interface includes a data storage capacity of up to 10 years
- Oversized air-cooled condenser improves the robustness of the refrigeration system, reliability and refrigeration efficiency

Ergonomic Design

- The temperature data of the newly improved storage management system is downloadable from the USB port
- Traceability of temperature data
- Heated double-pane glass door allows a clear view of stored products without condensation at 32°C and 85% relative humidity ambient conditions
- LED interior light saves energy and provides bright lighting of interior for easy product location and identification
- Shelves with label holders meet demands required for quick and effective product archiving and retrieving

Safety

- Microprocessor control with digital display
- Temperature uniformity within 3°C
- Malfunction alarms include high/low temperature, door ajar, sensor error, power failure, low battery and remote alarm interface

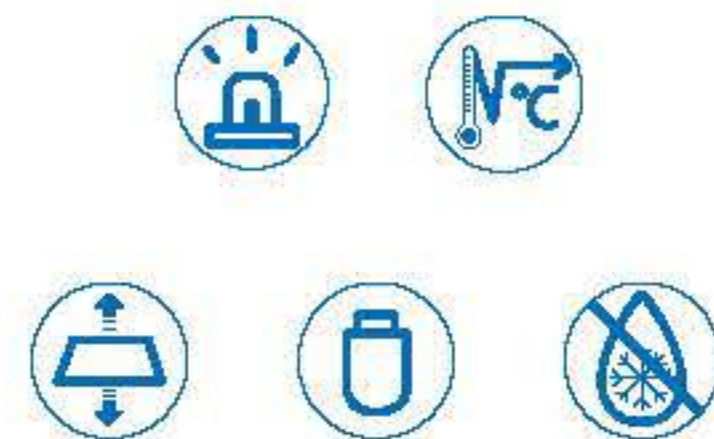
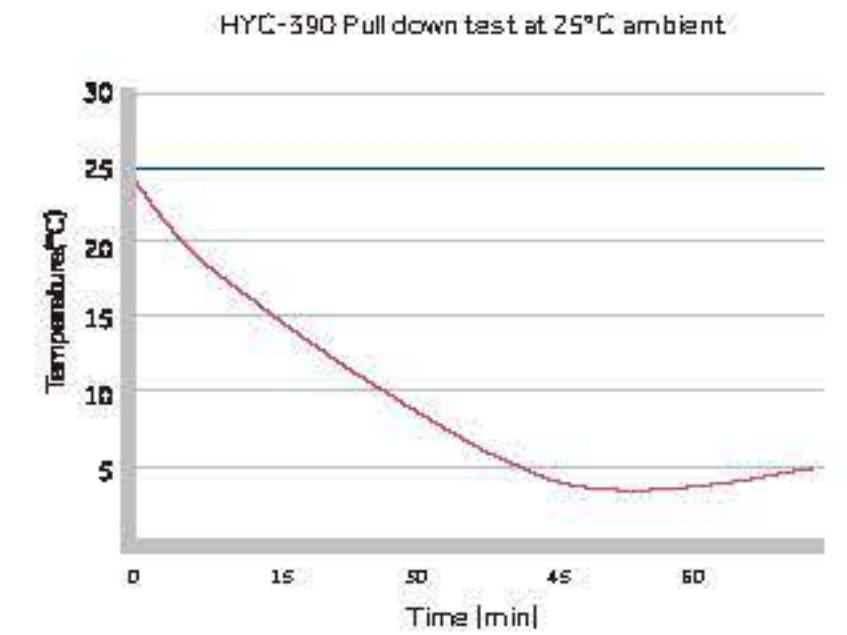
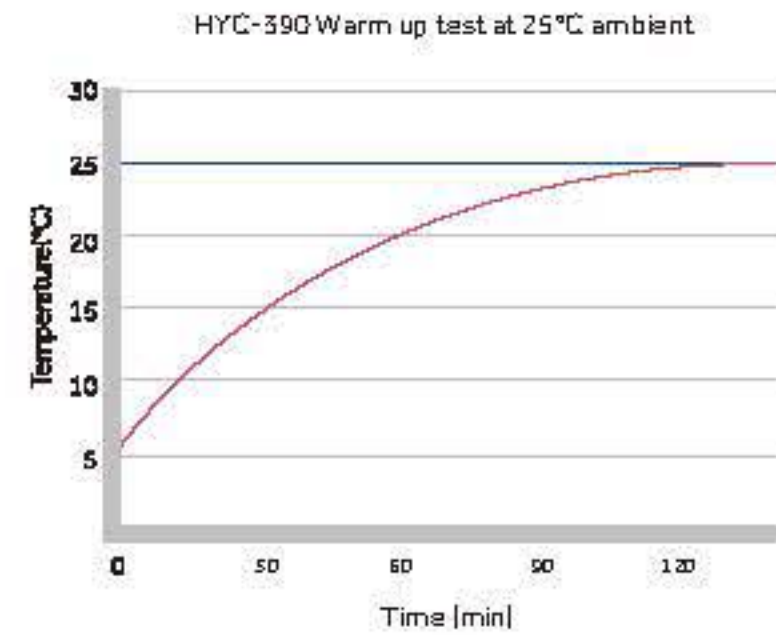

Easy to Install, Ergonomic and Reliable

bitstrong are pioneers in under-counter pharmacy refrigerator design and manufacturing, offering ultra-low noise system, safety lock, complete alarm system for sample safety and protection.



HYC-118

HYC-118A

Reliability and Key Features

- Energy efficient hydrocarbon (HC) refrigeration system
- Permanently lubricated cooling fan for safety and longevity
- Forced-air cooling with optimized air distribution system designed to achieve maximum temperature uniformity and stability
- Optimized refrigeration system design for more effective cooling and speedy recovery
- Temperature variation within $\pm 3^{\circ}\text{C}$
- Chamber temperature range $2\text{--}8^{\circ}\text{C}$
- Microprocessor control, digital display and temperature adjustment with an increment of 0.1°C
- Designed for ambient temperature $10\text{--}32^{\circ}\text{C}$ with humidity below 70%

Safety

- Equipped with a complete temperature alarm system featuring audible buzzer and visual flashing light
- Capable of alerting failures due to high and low temperature, sensor error, door ajar, power failure, and remote alarm interface

Ergonomic Design

- Interior LED light
- Safety lock to prevent unauthorized access

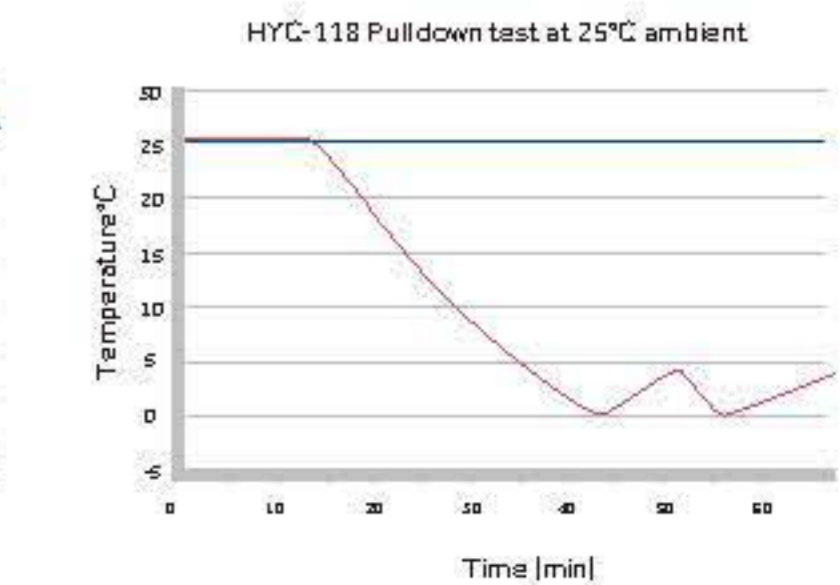
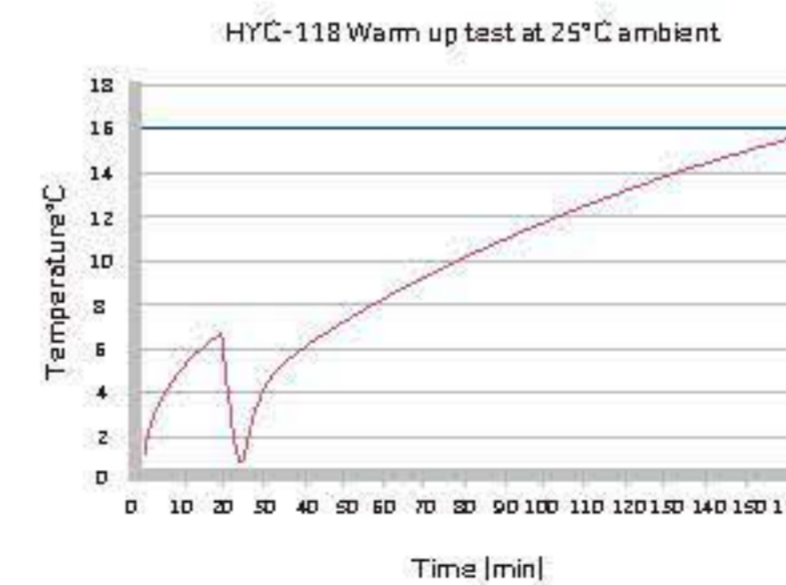

Specifications



Model	HYC-68		HYC-68A		HYC-118		HYC-118A		HYC-290		HYC-390		HYC-390F		HYC-610		HYC-940		HYC-940F		HYC-1378				
Technical Data	Cabinet Type	Upright, Solid Door		Upright, Glass Door		Upright, Solid Door		Upright, Glass Door		Upright, Single Door		Upright, Single Door		Upright, Single Door		Upright, Single Door		Upright, Double Glass Door		Upright, Double Solid Door		Upright, double door			
	Climate Class	N		N		N		N		N		N		N		ST		N		N		N			
	Cooling Type	Forced Air Cooling		Forced Air Cooling		Forced Air Cooling		Forced Air Cooling		Forced Air Cooling		Forced Air Cooling		Forced Air cooling		Forced Air Cooling		Forced Air Cooling		Forced Air Cooling		Forced Air Cooling			
	Defrost Mode	Auto		Auto		Auto		Auto		Auto		Auto		Auto		Auto		Auto		Auto		Auto			
	Refrigerant	HC		HC		HC		HC		HC		HC		HC		HC		HC		HC		HC		HC	
	Sound Level [dB(A)]	41		41		41		41		43		41		43		41		43		43		43		43	
Performance	Temperature Range [°C]	2-8		2-8		2-8		2-8		2-8		2-8		2-8		2-8		2-8		2-8		2-8			
	Controller	Microprocessor		Microprocessor		Microprocessor		Microprocessor		Microprocessor		Microprocessor		Microprocessor		Microprocessor		Microprocessor		Microprocessor		Microprocessor		Microprocessor	
Electrical Data	Display	LED		LED		LED		LED		LED		LED		LED		LED		LED		LED		LED		LED	
	Power Supply [W/Hz]	220-240/50		115/60		220-240/50/60		115/60		220-240/50/60		115/60		220-240/50		220-240/50		115/60		220-240/50/60		115/60		220-240/50/60	
	Power [W]	84		150		84		150		190		190		250		230		200		350		240		360	
Dimensions	Electrical Current [A]	0.6		1.7		0.6		1.7		1.4		1.4		1.5		1.5		2.2		1.8		2.4		1.8	
	Capacity [L/Cu.Ft]	68/2.4		68/2.4		118/4.2		118/4.2		290/10.2		390/13.8		390/13.8		610/21.6		890/31.4		890/31.4		1378/48.7		1378/48.7	
	Net/Gross Weight [approx]	kg	38/40		38/40		41/46		46/51		105/127		116/139		106/129		204/227		227/279		207/259		310/360		
		lbs	85.8/88.2		85.8/88.2		90.5/101.5		101.5/112.5		231.8/280.1		255.8/306.6		233.8/284.5		449.7/500.4		500.4/615.1		456.4/571.1		683.4/795.7		
	Interior Dimensions [W*D*H]	mm	415*385*505		415*385*505		515*415*630		515*415*630		530*555*1080		530*555*1380		530*555*1380		680*640*1400		1030*590*1425		1030*590*1425		1320*700*1500		
		in	16.3*15.2*19.9		16.3*15.2*19.9		20.3*16.3*24.8		20.3*16.3*24.8		20.9*21.9*42.5		20.9*21.9*54.3		20.9*21.9*54.3		26.8*25.2*55.1		40.6*23.2*56.1		40.6*23.2*56.1		52.0*27.6*59.1		
Exterior Dimensions [W*D*H]	mm	495*580*660		495*580*660		597*635*835		597*635*810		597*635*835		597*635*810		665*710*1665		665*710*1965		665*710*1965		780*840*1945		1130*755*1980		1440*925*1980	
	in	19.5*22.8*26.0		19.5*22.8*26.0		23.5*25.0*32.9		23.5*25.0*31.9		23.5*25.0*32.9		23.5*25.0*31.9		26.2*28.0*65.6		26.2*28.0*77.4		26.2*28.0*77.4		30.7*33.1*76.6		44.5*29.7*78.0		56.7*36.4*78.0	
Packing Dimensions [W*D*H]	mm	540*640*710		540*640*710		680*690*910		680*690*910		690*790*1810		690*790*2110		690*790*2110		865*945*2090		1250*850*2130		1250*850*2130		1570*1010*2120			
	in	21.3*25.2*28.0		21.3*25.2*28.0		26.8*27.2*35.8		26.8*27.2*35.8		27.1*31.0*71.1		27.1*31.0*82.9		27.1*31.0*82.9		34.1*37.2*82.5		49.2*33.5*83.9		49.2*33.5*83.9		61.8*39.8*83.5			
Container Load [20*40*40H]		108/228/228		108/228/228		48/102/102		48/102/102		21/42/42		21/42/42		21/42/42		12/26/26		8/18/18		8/18/18		6/12/12			
Alarms	High/Low Temperature	Y		Y		Y		Y		Y		Y		Y		Y		Y		Y		Y			
	Remote Alarm	Y		Y		Y		Y		Y		Y		Y		Y		Y		Y		Y			
	Power Failure	Y		Y		Y		Y		Y		Y		Y		Y		Y		Y		Y			
	Sensor Error	Y		Y		Y		Y		Y		Y		Y		Y		Y		Y		Y			
	Low Battery	Y		Y		Y		Y		Y		Y		Y		Y		Y		Y		Y			
	Door Ajar	Y		Y		Y		Y		Y		Y		Y		Y		Y		Y		Y			
Accessories	Caster	Y		Y		Y		Y		Y		Y		Y		Y		Y		Y		Y			
	Foot	Y		Y		Y		Y		Y		Y		Y		Y		Y		Y		Y			
	Port hole	Y		Y		Y		Y		Y		Y		Y		Y		Y		Y		Y			
	Shelves/Drawers	2/1		2/1		Y		Y		5/-		7/-		7/-		6/-		12/-		12/-		12/-			
	USB Interface	N/A		N/A		3/1		3/1		Y		Optional		Y		Optional		Optional		Optional		N/A			
	Printer	N/A		N/A		N/A		N/A		N/A		N/A		N/A		N/A		Optional		Optional		Optional			
Others	Temperature Recorder	N/A		N/A		N/A		N/A		N/A		N/A		N/A		Optional		Optional		Optional		Optional			
	Certification	CE UL		CE UL		CE UL		CE UL		UL CE		UL CE		CE UL ENERGY STAR		CE UL		CE UL		CE UL		CE UL			

Product appearance and specifications are subject to change without notice.



Blood Bank Refrigerator



HXC-429TR

HXC-629TR

HXC-1369TR



Microcomputer Control

The temperature inside the unit is controlled within $4\pm 1^{\circ}\text{C}$ with temperature control accuracy of 0.1°C and the large high-definition LCD touch screen display makes it convenient to observe.



Inverter Compressor

High efficiency and energy saving, low noise and long service life.



Three-layer Glass Foam Door

With large viewing three-layer glass foam door design, surface glass with LOW-E film to reduce heat transfer efficiency with no condensation at 25°C and 85% humidity environment.



Standard USB Port

With optional disc temperature recorder.



Multiple Fault Alarms

High/low temperature alarm, power failure alarm, door opening alarm, sensor failure alarm, and low battery alarm. It is configured with remote alarm interface with two alarm modes (sound buzzer alarm and light flashing alarm).



Speed Control Condenser Fan

High efficiency and energy saving, low noise and long service life.



Double Protection of Mechanical Door Lock and Electromagnetic Lock

Electromagnetic lock can realize NFC card punching unlocking and fingerprint unlocking function.

Information Flow



Operation Instructions

Blood Bag Inbound:



Blood Bag Outbound:



Specifications

Product Model No.	Voltage (V/Hz)	Internal Temperature ($^{\circ}\text{C}$)	External Dimension (W*D*H mm)	Internal Dimension (W*D*H mm)	Effective Volume (L)	NW / GW (Kg)	Stainless Steel Shelf (layers)	Loading Capacity (400 ml blood bag)
HXC-429TR	220/50	4 ± 1	625*940*1830	505*680*1315	429	190/230	5	120
HXC-629TR	220/50	4 ± 1	765*940*1980	644*680*1456	629	235/280	6	192
HXC-1369TR	220/50	4 ± 1	1545*940*1980	1425*680*1456	1369	430/490	6	384

Scope of Application

Suitable for blood transfusion departments, operating rooms, and emergency rooms, etc. of the hospitals

Product Advantages

Drastically Improves the Speed of Delivery

Innovative blood bank system, enables the blood to be advanced to the operating room to achieve 1-minute rapid blood collection.

Reduce Waste and Improve Efficiency

Electronic blood matching within 1 minute, reducing the cross matching time and reagent consumption. Quick and precise blood matching, combined with intelligent lighting indicators guide, guarantees the accurate identification and safe use of blood, without waste.



Intelligent Blood Management System

Allows integration and coordination of blood recovery within hospitals and blood allocation between hospitals and even across regions through the blood network cloud platform. Enabling the rational use of blood upon demand, thus reducing resource consumption.



Intelligent Blood Management System

Quickly and accurately identify blood bag location using onboard blood information management system.

The patient's blood matching information is shown and a blood bag automatically selected and a request for the bag is sent.

The system reads the blood information and light up indicators guide the user to the correct blood bag location.

Blood information is cross-checked and blood is issued. Inventory is automatically updated within the blood management system.

Specifications

Model	HXC-149R	HXC-429R	HXC-629R	
Technical Data	Type	Drawer-Type	Drawer-Type	
	Climate Class	N	N	
	Cooling Type	Forced air cooling	Forced air cooling	
	Defrost Mode	Auto	Auto	
	Refrigerant	R600a	R600a	
Performance	Sound Level [dB(A)]	40	41	
	Temperature Range [°C]	4±1	4±1	
Control	Ambient Temperature [°C]	16-32	16-32	
	Controller	Microprocessor	Microprocessor	
Electrical Data	Display	LCD Touchscreen	LCD Touchscreen	
	Power Supply [V/Hz]	220-240/50 230-/90/60	220-240/50 230-/50/60	
	Power [W]	250	280	
Dimensions	Electrical Current [A]	1.5	1.8	
	Capacity [L/Cu.Ft]	149/5.3	429/15.1	
	Blood Storage Capacity [450ml blood bag]	18	60	
	Net/Gross Weight [approx]	kg	129/179	245/280
		lbs	283.8/393.8	539/616
	Interior Dimensions [W*D*H]	mm	505*560*610	505*680*1315
		in	19.7*32.3*23.8	19.7*26.5*51.3
	Exterior Dimensions [W*D*H]	mm	625*820*1425	925*940*1830
		in	24.4*30.2*55.6	36.1*36.7*71.4
	Packing Dimensions [W*D*H]	mm	740*945*1575	725*985*1940
in		28.9*36.9*61.4	28.3*38.4*75.7	
Alarms	Container load [20/40/40*H]	18/36/36	18/35/35	
	High/Low Temperature	Y	Y	
	Power Failure	Y	Y	
	Sensor Error	Y	Y	
	Low Battery	Y	Y	
	Door Ajar	Y	Y	
	Remote Alarm	Y	Y	
Accessories	Caster	4	4	
	Foot	2	2	
	Porthole	Y	Y	
	Drawers	9	30	
	USB Interface	Y	Y	
Others	Temperature Recorder	Y	Y	
	Certificate	CE UL	CE UL	

R suffix - RFID with IoT model for blood bag management
Product appearance and specifications are subject to change without notice

Self-Service Blood Distribution with Smart IoT Technology

Self-service blood distribution for blood transfusion departments

- After blood cross matching is completed for the blood bags, specified blood collection permissions will be allocated to the different blood using departments to achieve self-help blood distribution; self-help blood collection at night can save labor cost and improve efficiency.

Mobile blood storage points set up by blood stations

- The refrigerators may be used as mobile blood storage points in hospitals to guarantee the applications of emergency blood use, achieve zero waiting for blood use, and guarantee the timely blood use of patients.



HXC-629ZZ

Product Advantages

Electronic checking and bar code management

- Blood bag warehouse-in and warehouse-out management can be achieved by scanning of the blood donation codes and the product codes on the bags.
- The system can take the specified blood bags for the work staff accurately after identifying the operators and checking the blood bags to be error-free.



A drawer corresponds to a lock

Safe and reliable, making blood collection process traceable

- Equipped with fingerprint module and NFC card punching module, providing dual permission modes to open the electromagnetic lock;
- Each drawer is equipped with an independent electronic lock to ensure that only the unique and correct blood bag can be taken out in each blood collection operation;
- The camera module can take photos of the operators automatically and transmit them to the platform to achieve operation information traceability.



Self-service printing

Ergonomic design

- Smart dual screen setting realizes simple and intuitive LCD screen display and richer man-machine interactions.
- Upon checking of the warehouse-out blood bag's information, self-help printing of Blood Collection Sheet for Clinical Blood Transfusion and Blood Distribution Record Sheet is available.

Man-machine interaction, making management visual

- The intelligent blood management system can display the blood donation codes, product codes, blood types, blood quantities, expiry dates and other information of the stored blood bags in real time, realizing one-key query of the stock blood information.
- It can clearly show the storage location of the blood bag with the closest expiry date and follow the first-in first-out management practices.

Real-time control of freezer temperature

- Double temperature control composed of 6 high precision sensors and mechanical thermostat against low temperature makes control more accurate and maintains the refrigerator temperature constant at $4\pm 1^{\circ}\text{C}$.

Specifications

Model	Voltage (V/Hz)	Power (W)	Temperature inside the refrigerator (°C)	Uniformity (°C)
HXC-629ZZ	220/50	300	2-6	4±1

External dimensions (W*D*H mm)	Internal dimensions (W*D*H mm)	Effective volume (L)	Blood bag volume (400ml blood bag)	Overall construction
1290*940*1980	645*680*1455	629	72	Single door

Blood Bank Refrigerator

Advanced Blood Bank Refrigerator with Touchscreen



HXC-1369T HXC-629T HXC-429T HXC-149T

Product Advantages



Control Interface

- The simple and intuitive high-definition LCD touch screen can display temperature graph, working status, events and alarm record.



Real-time Control of Internal Temperature

- A dual control system of six high-precision sensors and mechanical thermostat ensures the temperature inside the cabinet is maintained at $4^{\circ}\text{C} \pm 1^{\circ}\text{C}$.



Stable and Reliable Operation

- The refrigeration system is powered with a high-quality, energy-efficient inverter compressor and variable speed fan motors. Temperature control responds quickly and reliably for a more uniform temperature using less power and lower noise.



Multiple Safety Protection

- Multiple alarms include high and low temperature, power failure, door ajar, sensor failure, and low battery. Sound buzzer, visual flashing light and remote contacts are standard alarm features. Built-in battery provides power to the alarm system in the event of a mains power failure.
- Optional fingerprint and standard NFC swipe card module.

Blood Bank Refrigerator

Advanced Blood Bank Refrigerator with LED Display



HXC-1369 HXC-629 HXC-429 HXC-149

Product Advantages



With Multiple Temperature Control to Guarantee Constant and Precise Temperature

- The inside temperature is constant within $4 \pm 1^{\circ}\text{C}$, the digital temperature display resolution at 0.1°C .
- Equipped with 6 high-precision sensors and a mechanical thermostat which enables more accurate air cooling and temperature control to ensure uniform temperature inside the unit, maintained within the specified temperature range. The multi-layer inner door design reduces thermal loss after door openings and further ensures the temperature stability inside the cabinet.



With Multiple Safety Guarantees to Provide Worry-Free Service

- Equipped with complete alarm function, including alarm on high and low temperature, power failure, door opening, sensor failure, and low battery. Two alarm modes including audible buzzer and visual lights with remote alarm interface.
- Back-up battery design ensures alarm and temperature readings continue to operate in the event of a mains power failure.
- NFC swipe card module, with safer storage management.



Standard USB Interface

- Ability to record temperature data for ten years using the USB interface, an optional disc temperature recorder is also available

Specifications

Model	HXC-149		HXC-429		HXC-629		HXC-1369		HXC-149T		HXC-429T		HXC-629T		HXC-1369T			
Technical Data	Type	Basket-Type		Basket-Type		Basket-Type		Basket-Type		Drawer-Type		Drawer-Type		Drawer-Type		Drawer-Type		
	Climate Class	N		N		N		N		N		N		N		N		
	Cooling Type	Forced air cooling		Forced air cooling		Forced air cooling		Forced air cooling		Forced air cooling		Forced air cooling		Forced air cooling		Forced air cooling		
	Defrost Mode	Auto		Auto		Auto		Auto		Auto		Auto		Auto		Auto		
	Refrigerant	R600a		R600a		R600a		R600a		R600a		R600a		R600a		R600a		
Performance	Sound Level [dB(A)]	39		40		40		41		39		40		40		41		
	Temperature Range [°C]	4±1		4±1		4±1		4±1		4±1		4±1		4±1		4±1		
Control	Ambient Temperature [°C]	16-32		16-32		16-32		16-32		16-32		16-32		16-32		16-32		
	Controller	Microprocessor		Microprocessor		Microprocessor		Microprocessor		Microprocessor		Microprocessor		Microprocessor		Microprocessor		
Electrical Data	Display	LED		LED		LED		LED		LCD		LCD		LCD		LCD		
	Power Supply [V/Hz]	220-240/50 230-/50/60		220-240/50 230-/50/60		220-240/50 230-/50/60		220-240/50 230-/50/60		220-240/50 230-/50/60		220-240/50 230-/50/60		220-240/50 230-/50/60		220-240/50 230-/50/60		
	Power [W]	240		245		255		320		215		245		255		320		
Dimensions	Electrical Current [A]	1.4		1.5		1.5		2		1.3		1.5		1.5		2		
	Capacity [L/Cu.Ft]	149/5.3		429/15.1		629/22.2		1369/48.3		149/5.3		429/15.1		629/22.2		1369/48.3		
	Blood Storage Capacity [450ml blood bags]	60		195		312		624		60		195		312		624		
	Net/Gross Weight [approx]	kg	97/125		169/204		187/217		345/410		108/136		182/217		212/252		380/445	
		lbs	213.4/275		371.8/448.8		411.4/477.4		759/902		237.6/299.2		400.4/477.4		466.4/554.4		836/979	
	Interior Dimensions [W*D*H]	mm	505*560*610		505*680*1315		645*680*1455		1425*680*1455		505*560*610		505*680*1315		645*680*1455		1425*680*1455	
		in	19.7*32.3*23.8		19.7*26.5*51.3		25.2*26.5*56.7		55.6*26.5*56.7		19.7*32.3*23.8		19.7*26.5*51.3		25.2*26.5*56.7		55.6*26.5*56.7	
Exterior Dimensions [W*D*H]	mm	625*820*1150		625*940*1830		765*940*1980		1545*940*1980		625*820*1150		625*940*1830		765*940*1980		1545*940*1980		
	in	24.4*30.2*44.9		24.4*36.7*71.4		29.8*36.7*77.2		60.3*36.7*77.2		24.4*30.2*44.9		24.4*36.7*71.4		29.8*36.7*77.2		60.3*36.7*77.2		
Packing Dimensions [W*D*H]	mm	720*920*1220		725*985*1940		875*995*2090		1610*995*2090		720*920*1220		725*985*1940		875*995*2090		1610*995*2090		
	in	28.1*35.9*47.6		28.3*38.4*75.7		34.1*38.8*81.5		62.8*38.8*81.5		28.1*35.9*47.6		28.3*38.4*75.7		34.1*38.8*81.5		62.8*38.8*81.5		
Container load [20"/40"/40"H]	18/38/76		18/35/35		12/26/26		7/14/14		18/38/76		18/35/35		12/26/26		7/14/14			
Alarms	High/Low Temperature	Y		Y		Y		Y		Y		Y		Y		Y		
	Power Failure	Y		Y		Y		Y		Y		Y		Y		Y		
	Sensor Error	Y		Y		Y		Y		Y		Y		Y		Y		
	Low Battery	Y		Y		Y		Y		Y		Y		Y		Y		
	Door Ajar	Y		Y		Y		Y		Y		Y		Y		Y		
	Remote Alarm	Y		Y		Y		Y		Y		Y		Y		Y		
Accessories	Caster	4		4		4		4		4		4		4		4		
	Foot	2		2		2		2		2		2		2		2		
	Porthole	Y		Y		Y		Y		Y		Y		Y		Y		
	Baskets	6		15		24		48		6		15		24		48		
	Shelves/Drawers	2/0		5/0		6/0		12/0		0/2		0/5		0/6		0/12		
	Innerdoors	2		5		6		12		0		0		0		0		
	USB Interface	Y		Y		Y		Y		Y		Y		Y		Y		
Temperature Recorder	Y		Y		Y		Y		Y		Y		Y		Y			
Others	Certificate	CE	UL	CE	UL	CE	UL	CE	UL	CE	UL	CE	UL	CE	UL	CE	UL	

T suffix - Advanced with touch screen
Product appearance and specifications are subject to change without notice

blood bank refrigerator is specially designed to store whole blood and blood derivatives. These refrigerators can also be used to store pharmacy and biological materials in hospitals and laboratories.

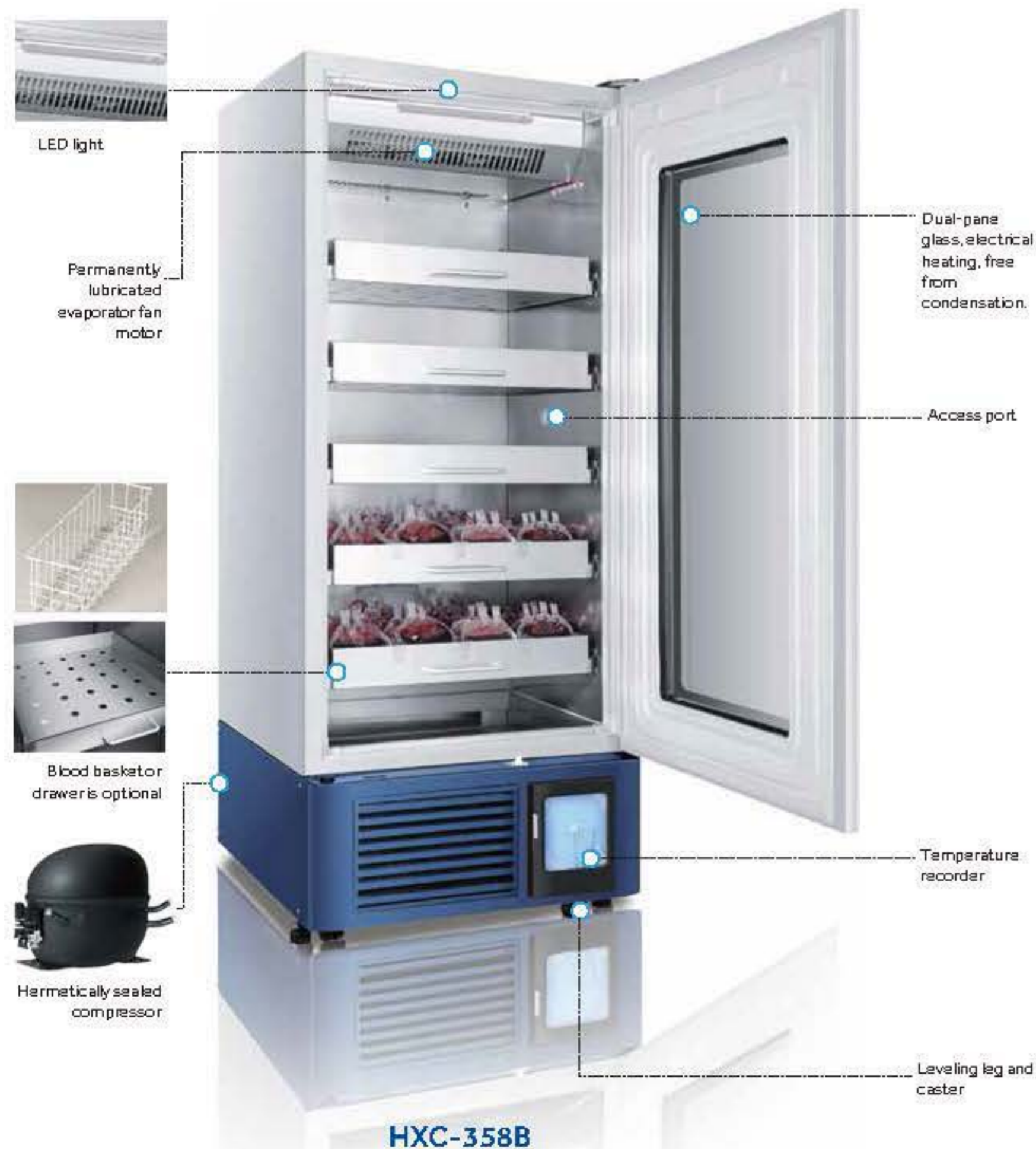

Blood Bank Refrigerators (BBR) are designed and built to meet the following requirements:

- AABB (American Association of Blood Banks)
- DIN 58371 (Germany, "Blutkonserven- Kühlgeräte"/Blood Refrigerators)
- BIS 4376-1: 1991 (UK, "Electrically operated blood storage refrigerators")

Reliability

- Microprocessor controlled forced-air cooling system with heat compensation system
- Digital temperature display for upper and lower sections in chamber with 0.1°C resolution

Key Features

- Consistent cabinet temperature 2-6°C
- High-tech integrated sensors to display and control temperature
- Standard temperature recorder (Optional for HXC-158)
- Auto-defrost to remove moisture on cooling surface
- Large digital display for ease of observation
- Basket or drawer styles for managing stored products

Safety

- Dual displays of operational parameter (temperature recorder display)
- Built-in backup battery to display temperature and to operate audible and visual alarm systems for up to 48 hours without AC power
- NC/NO Terminals for remote alarm connections
- Five alarm conditions: High/low temperature, power failure, sensor error, door ajar, low voltage in backup battery

Ergonomic Design

- Safety lock to prevent unauthorized access
- Storage space designed for easy sorting of a variety of blood products
- Optional baskets or stainless steel drawers
- Caster design
- Interior light



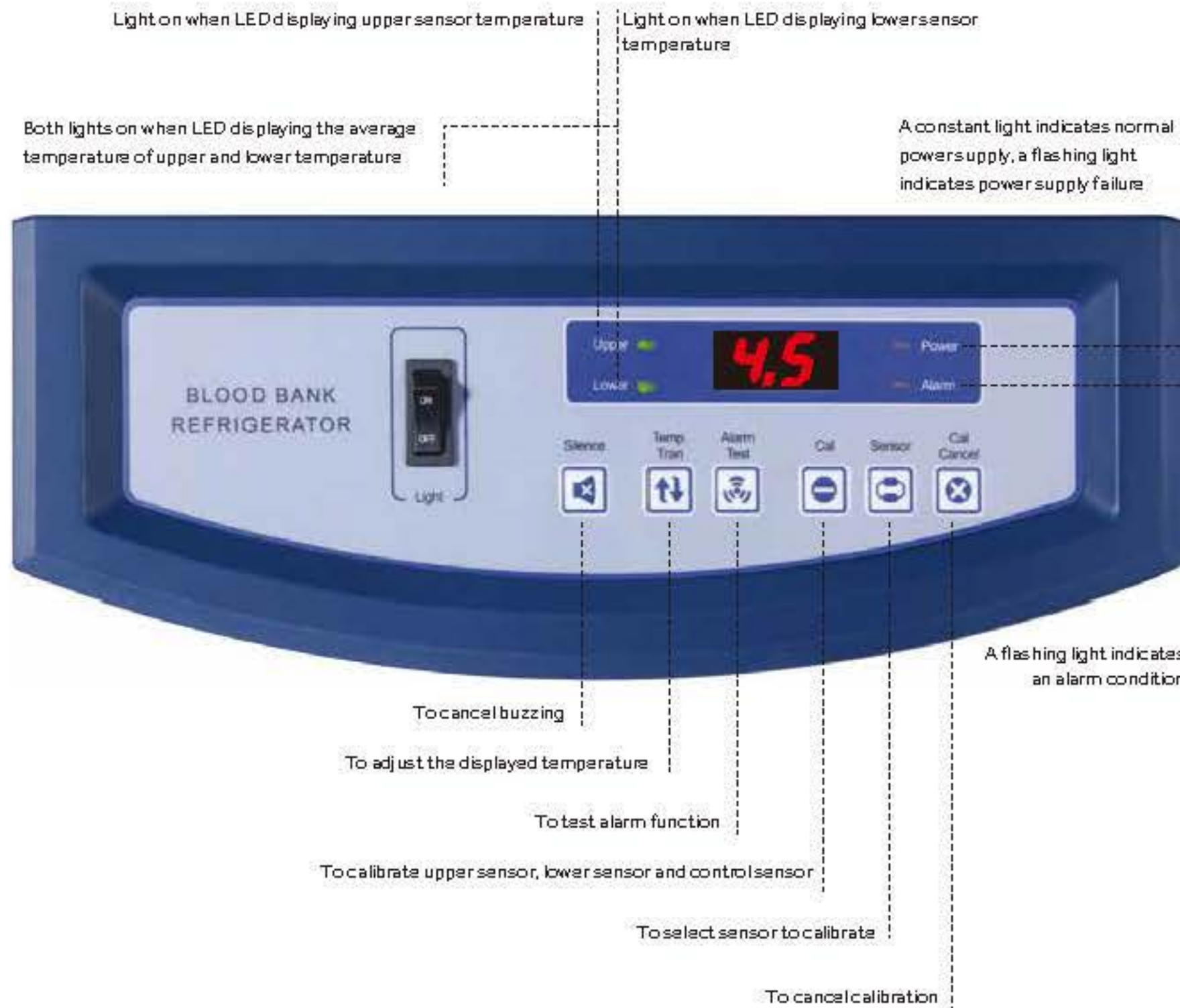

Alarm	Alarm Triggering Condition
High Temperature	Temperature reaches the warm alarm limit
Low Temperature	Temperature reaches the low alarm limit
Power Failure	Equipment loses power
Probe Failure	1. Main cabinet temperature control sensor fails 2. Condenser sensor fails 3. Ambient sensor fails 4. Heat exchanger sensor fails
Low Battery	Battery capacity runs low or battery switch is not turned on
Door Ajar	Door opening time exceeds 600 seconds



Standard drawers can be optionally fitted with adjustable dividers to ensure stored products neatly organized.

HXC-608 Pull down test at 32°C ambient

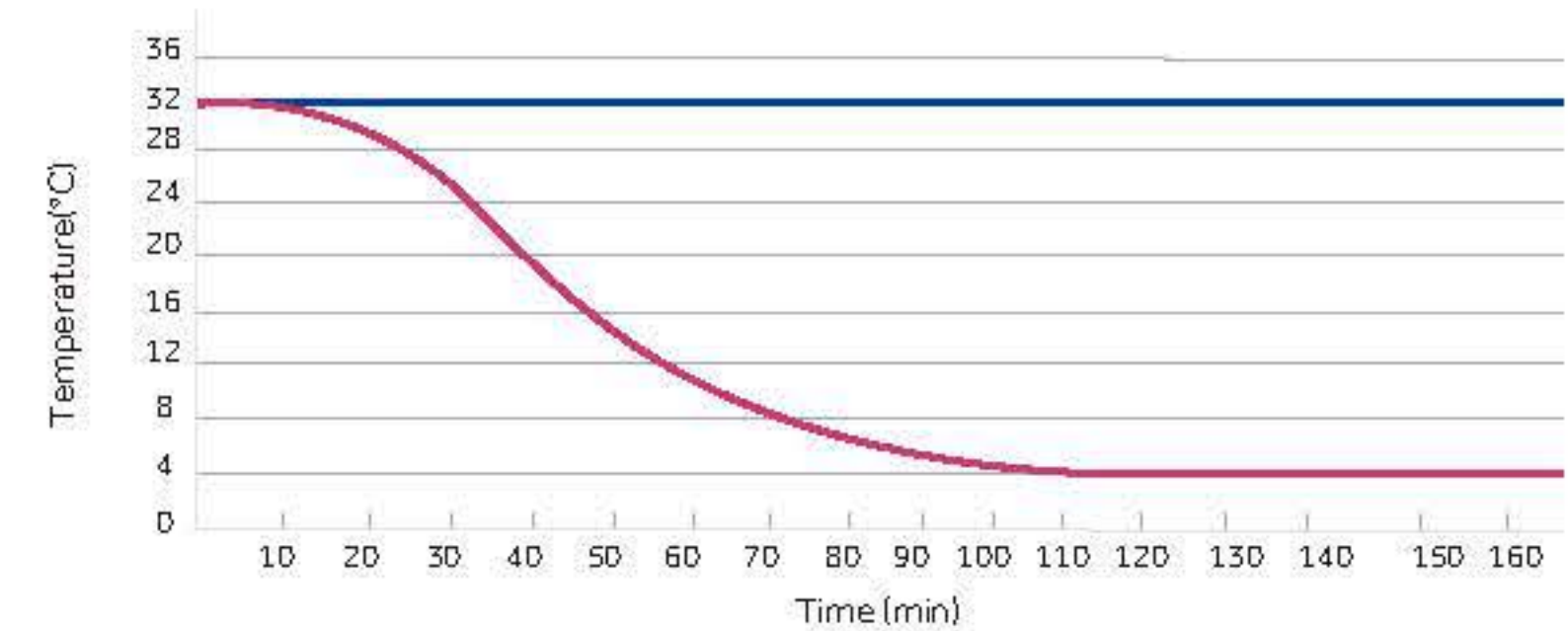

HXC-608 Warm up test at 32°C ambient

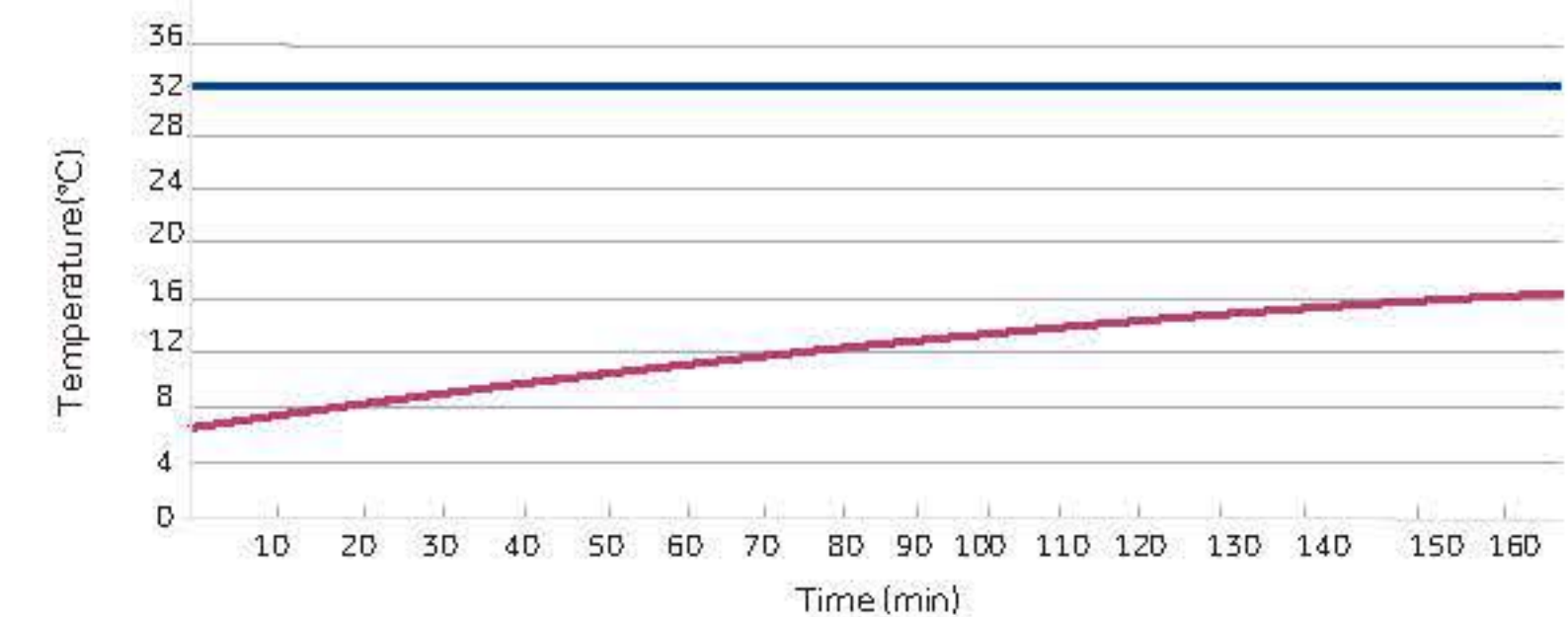



HXC-1308

Ergonomic Design

- Auto-closing door
- It provides a clear view of stored items through the large glass windows
- Two access ports for ease of testing
- Built-in 7-day circular chart recorder, standard USB port
- Bright, energy-efficient LED interior lighting
- Environmentally friendly CFC-free refrigerant
- "One lock one key" to safeguard valuable contents

Application

- HXC-1308(B) is a large capacity blood refrigerator designed for storage of whole blood products, and biological products. It is frequently installed in blood banks, hospitals and disease prevention centers

Advantages

- **More Stable:** The temperature range is 2-6°C
- **Safety:** Anti-low/high temperature function
- Double-pane electric heated glass door
- Multilayer adjustable shelves
- Baskets or optional stainless steel drawers
- Each shelf can be labelled
- **Ensures the safety in daily use**

Function

- Storage of large blood bags
- Each blood basket holds twelve 450 ml blood bags. Each drawer can hold sixty 450 ml blood bags
- HXB-1308 unit's capacity is 576*450 ml blood bags. HXC-1308B can hold 720*450 ml blood bags.
- Microprocessor system works with an optimized refrigeration system and controls the temperature within 2°C to 6°C with a quick recovery after a door opening
- Redundant mechanical control system allows the unit to operate and maintain proper temperature should there be a malfunction on the electronic control system
- Defrosting function is performed automatically with minimal impact to temperature
- Multiple Alarms: High/low temperature alarm, door open alarm, sensor error alarm, remote alarm under audible (buzzer) and visible (light flashing) alarm
- Backup battery supports the digital display and alarm system for up to 48 hours in the event of a mains power failure



HXC-1308B



HXC-1308B

Biomedical's 4 °C Medical Blood Refrigerator:
High efficiency, energy-saving, safe and reliable, smart control.



HXC-106



Microprocessor Control System

The temperature range $4 \pm 1^\circ\text{C}$, with temperature accuracy of 0.1°C .



Air Cooling Design

The temperature in all corners of the cabinet is maintained within the calibrated temperature range, and the test hole design is added to meet the actual needs of the user.



Multiple Fault Alarms

High and low temperature alarm, power failure alarm, door ajar alarm, sensor error alarm, low battery with a remote alarm interface, two alarm modes (sound beeping alarm and light flashing alarm).



Multiple Protection

Startup delay protection, stop interval protection, display panel password protection, power failure memory data protection, sensor error protection.



Remote Alarm Function

Can connect alarm to other rooms to achieve alarm function.



Automatic Evaporation of Condensed Water after Collection

Avoid the trouble of manual treatment of condensed water.

Product Features

The Door:

Vertical single door design, double layer electric heating glass door and self-closing function.

Materials

The shell and inner liner are sprayed with steel plate, which is anticorrosive and bacteriostatic.

Compressor

Deeply optimized refrigeration system, international brand SECOP compressor, German imported brand EBM energy saving, low noise, long service life.

Interior lighting:

The cabinet is equipped with LED lights and external independent light switches.

Door lock and door lock alarm:

Prevent random door opening.

Door handle:

Easy to open

Foot:

Stable and adjustable

LED digital display:

The internal temperature $2-6^\circ\text{C}$, digital display of upper and lower temperature, the average temperature display and the resolution of 0.1°C .

Air cooling design:

Ensure that the temperature in any corner of the box is maintained within the calibration temperature range.

The temperature measuring box is used to monitor the temperature in the cabinet in real time.

3 shelves, 4 blood baskets, blood basket with a label slot, easy to label. Capable of storing 54 bags of 400ml blood totally.

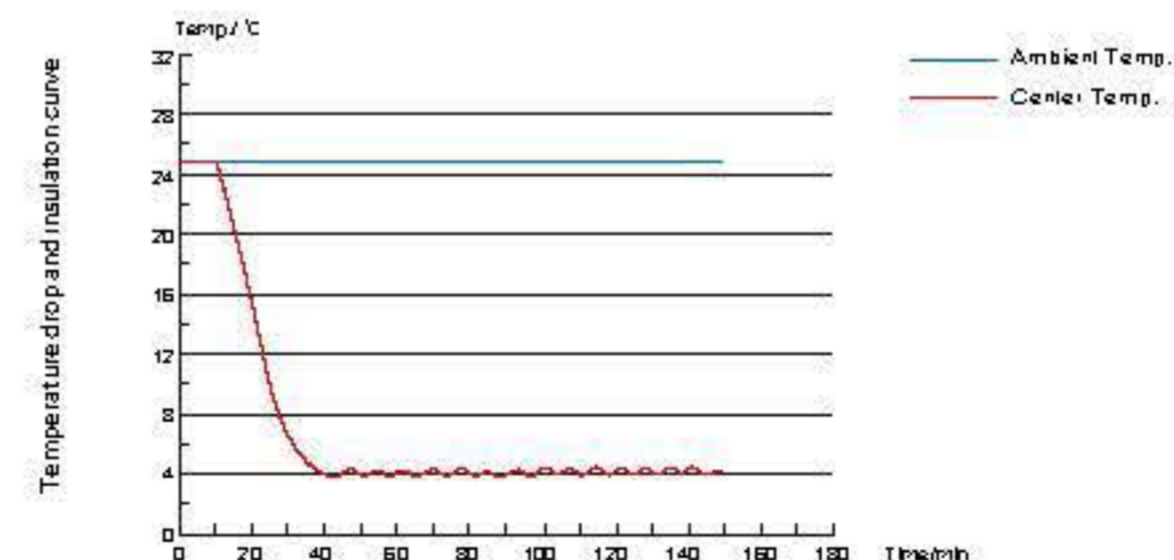



Specifications

Model	HXC-15B	HXC-35B	HXC-60B	HXC-130B	HXC-106	HXC-158B	HXC-358B	HXC-608B	HXC-1308B		
Technical Data	Type	Basket-Type				Drawer-Type					
	Climate Class	ST	ST	ST	N	N	ST	ST	ST	N	
	Cooling Type	Forced aircooling	Forced aircooling	Forced aircooling	Forced aircooling	Forced aircooling	Forced aircooling	Forced aircooling	Forced aircooling	Forced aircooling	
	Defrost Mode	Auto	Auto	Auto	Auto	Auto	Auto	Auto	Auto	Auto	
	Refrigerant	CFC-Free	CFC-Free	CFC-Free	CFC-Free	R600a	CFC-Free	CFC-Free	CFC-Free	CFC-Free	
Performance	Sound level [dB(A)]	42	43	43	45	41	42	43	43	45	
	Temperature Range [°C]	4±1	4±1	4±1	4±1.5	4±1	4±1	4±1	4±1	4±1.5	
Control	Ambient Temperature [°C]	10-38	10-38	10-38	16-32	10-38	16-32	10-38	10-38	16-32	
	Controller	Microprocessor	Microprocessor	Microprocessor	Microprocessor	Microprocessor	Microprocessor	Microprocessor	Microprocessor	Microprocessor	
Electrical Data	Display	LED	LED	LED	LED	LED	LED	LED	LED	LED	
	Power Supply [V/Hz]	220-240/50/60	220-240/50/60	220-240/50/60	220-240/50	220-240/50/60	220-240/50/60	220-240/50/60	220-240/50/60	220-240/50	
	Power [W]	350	460	490	850	253	350	460	490	850	
Dimensions	Electrical Current [A]	2.6	3	3.5	7.5	4.2	1.6	2.6	3	3.5	4.2
	Capacity [L/Cu.Ft]	158/5.6	358/12.7	608/21.5	1308/46.2	106/3.75	158/5.6	358/12.7	608/21.5	1308/46.2	
	Blood Storage Capacity [450ml blood bags]	84	200	300	576	54	84	200	360	720	
	Net/Gross Weight [approx]	[kg]	107/120	158/174	204/227	310/360	49/52	113/126	165/181	211/234	335/385
		[lbs]	235.9/264.6	348.3/383.6	449.7/500.4	683.4/793.7	108.03/114.64	249.1/277.8	363.8/399.0	465.2/515.9	738.5/848.8
	Interior Dimensions [W*D*H]	[mm]	460*370*950	620*490*1160	680*640*1400	1320*700*1500	430*350*830	460*370*950	620*490*1160	680*640*1400	1320*700*1500
		[in]	18.1*14.6*37.4	24.4*19.3*45.7	26.8*25.2*55.1	52.0*27.6*59.1	16.93*13.78*32.68	18.1*14.6*37.4	24.4*19.3*45.7	26.8*25.2*55.1	52.0*27.6*59.1
Exterior Dimensions [W*D*H]	[mm]	560*570*1530	720*690*1730	780*840*1945	1440*925*1980	500*514*1055	560*570*1530	720*690*1730	780*840*1945	1440*925*1980	
	[in]	22.0*22.4*60.2	28.3*27.2*68.1	30.7*33.1*76.6	56.7*36.4*78.0	19.69*20.24*41.54	22.0*22.4*60.2	28.3*27.2*68.1	30.7*33.1*76.6	56.7*36.4*78.0	
Packing Dimensions [W*D*H]	[mm]	645*675*1680	795*805*1870	865*945*2090	1570*1010*2120	565*615*1145	645*675*1680	795*805*1870	865*945*2090	1570*1010*2120	
	[in]	25.4*26.6*66.1	31.3*31.7*73.6	34.0*37.2*82.3	61.8*39.8*83.5	22.24*24.21*45.08	25.4*26.6*66.1	31.3*31.7*73.6	34.0*37.2*82.3	61.8*39.8*83.5	
Container load [20"/40"/40"H]		27/54/54	14/30/30	12/26/26	6/12/12	36/72/72	27/54/54	14/30/30	12/26/26	6/12/12	
Alarms	High/Low Temperature	Y	Y	Y	Y	Y	Y	Y	Y	Y	
	Power Failure	Y	Y	Y	Y	Y	Y	Y	Y	Y	
	Sensor Error	Y	Y	Y	Y	Y	Y	Y	Y	Y	
	Low Battery	Y	Y	Y	Y	Y	Y	Y	Y	Y	
	Door Ajar	Y	Y	Y	Y	Y	Y	Y	Y	Y	
	Remote Alarm	Y	Y	Y	Y	Y	Y	Y	Y	Y	
Accessories	Caster	Y	Y	Y	Y	Y	Y	Y	Y	Y	
	Foot	Y	Y	Y	Y	Y	Y	Y	Y	Y	
	Porthole	Y	Y	Y	Y	Y	Y	Y	Y	Y	
	Shelves/Baskets	4/4	5/20	6/24	12/48	3/3	-	-	-	-	
	Drawers/Inner doors	-/2	-/3	-/3	-/6	4/-	-/1	5/-	6/-	12/-	
	USB Interface	Optional	Optional	Optional	Y	Optional	N	Optional	Optional	Y	
Others	Temperature Recorder	Optional	Y	Y	Y	Y	Y	Y	Y	Y	
	Certification	CE	CE	CE	/	CE	CE	CE	CE	CE	

Product appearance and specifications are subject to change without notice

RFID Solution with Real-Time IoT Technology



DW-30L1280TR/DW-30L818TR

- RFID radio frequency, accurate management of plasma information, with automatic inventory and quick inquiry function.
- Hydrocarbon refrigeration, efficient and quick.
- Mobile terminal bio-link APP ensures real-time monitoring.
- Multiple alarms, safe and reliable.
- 10-inch large screen, easy to operate and more intuitive display.
- NFC permission management system combined with an electromagnetic lock, controllable flow direction and traceable information.



10-inch large touch screen, easy to operate, intuitive display.

- The 10-inch large touch screen ensures an easier operating experience. Capable of displaying interior real-time temperature, ambient temperature, temperature set point, input voltage, network status, user login status, temperature curve and new message/notebook, etc. Query interface can display plasma donation code, product code, blood type, blood volume, period of validity, etc.



Equipped with IoT function, ensuring real-time temperature monitoring.

- Equipped with IoT function, capable of sending users the equipment alarm information in the form of text messages. Download bio-link APP to monitor and check cabinet temperature, alarms and event logs from anywhere at anytime.



Bottom air inlet system, low noise

- Equipped with a special filter, ensuring the cleanness and safety of interior air.



Multi-compartment Storage Basket

- Multi-compartment storage basket design, streamlines plasma storage and placement, easy to access.



Dual Cooling System, Frost Free

- Equipped with dual cooling system, if one system fails, the other system can maintain the interior temperature at -25°C for an extended period, safe and reliable.
- RFID read-write board can read plasma label information, providing inventory plasma information statistics. Supports automatic inventory, one-key inventory and plasma in-out stock storage information.

Specifications

Model	Voltage (V/Hz)	Interior Temperature (°C)	Exterior Dimension (L*W*Hmm)	Interior Dimension (L*W*Hmm)	Effective Volume (L)	N.W./G.W. (kg)	loading Qty (bag)
DW-30L1280TR	220/50	-10~-35	1520*1065*1980	1320*752*1260	1280	440/505	576
DW-30L818TR	220/50	-10~-35	988*951*1980	750*755*1460	818	235/285	360

Active Cooling Solution



HZY-8Z/8ZA



HZY-15Z/15ZA

- Accurate control of the temperature between 2-6°C
- PCM ice pack
- Constant Temperature
- Complete process cold chain monitoring
- Replaces the traditional insulation method with Haier's transport cooler for transport
- Blood from blood transfusion department to clinical blood transfusion point



Low Noise

- The ultra-quiet fan is equipped with air outlets on both sides, noise level less than 34 dB providing a more comfortable environment.



Air Duct Structure



Easy to Clean

- The inner liner adopts aluminium oxidation process to make it smooth inside and easy to clean.



Internal Structure

Product Features

Semiconductor for active cooling, energy saving and environmental protection.

- Connect to power to cool unit to temperature, during transportation (without power) the unit will hold temperature. Small and easy to carry.

2-6°C precise temperature control, suitable for storage of biological products such as blood, medicines and reagents etc.

- Temporary blood storage to ensure blood safety at clinical blood stations.

Transport Cooler for Biological Products

Embedded with 4°C phase change PCM ice pack for cold storage, providing long insulation after power off to ensure blood safety during the transportation.



4°C PCM Ice Pack

- The PCM ice pack uses a 4°C phase change material with a freezing point greater than 2°C to ensure the low temperature preservation of blood and other biological samples.
- At 25 °C under no load, the time for temperature inside the box rises to 10 °C is more than 1 hour.
- At 25 °C under full load, the time for temperature inside the box rises to 10 °C is more than 2 hour.

Multiple Fault Alarms, Making it Safer to Use.

- High/low temperature alarm, power failure alarm, and sensor failure alarm.

The Power Supply Is Configured with Cigarette Lighter Plug, Easy for Vehicle Transportation.

- The power supply is configured to fit the vehicles internal power plug, easy for vehicle transportation.

Passive Cooling Solution

- Multi-function handle with casters for easy transportation
- Multi dimensional binding of orders and blood, and whole process cold chain monitoring
- From blood collection vehicle/blood donation house to blood center/blood station from blood center/blood station to hospital

Product Features

- LCD screen, real-time display of inside temperature, battery level and other information.
- Electromagnetic lock as standard, ability to scan QR code to open the unit, safeguarding the stored items.
- 4°C ice pack ensures cool storage temperatures with zero freezing to keep blood within safe storage temperature guidelines during transportation.



HZY-5B



HZY-35B

Product Features

- Real-time display of inside temperature.
- Integrated cold storage ice pack box, easy to access ice pack.
- Rotational moulding shell, anti-knocking, easy to carry.
- Multifunctional handle, sided casters, easy to be transported on flat road.



Specifications

	Model	HZY-5B	HZY-8Z	HZY-15Z	HZY-8ZA	HZY-15ZA	HZY-35B
Technical Data	Storage Temperature [°C]	/	2-6	2-6	2-6	2-6	/
	Operating Temperature [°C]	2-10	2-10	2-10	2-10	2-10	2-10
Dimensions	Exterior Dimensions [W*D*H mm]	285x186x200	320x265x260	520x300x270	320x265x260	520x300x270	550x328x370
	Interior Dimensions [W*D*H mm]	220x118x126	230x140x170	430x150x180	230x140x170	430x150x180	450x232x295
	Packing Dimensions [W*D*H mm]	357x277x287	393x362x367	595x375x404	393x362x367	595x375x404	674x455x490
	Net weight [kg]	2	4	6	4	6	9
	Gross weight [kg]	3	5	8	5	8	12
	Blood Bag Capacity	5	8	15	8	15	35
Functions	Cold Chain Monitoring	/	/	/	Y	Y	/
	NFC Unlock	/	/	/	/	Y	/
	Foam material	High density foam	High density foam	Polyurethane Cyclopentane	High density foam	Polyurethane Cyclopentane	Polyurethane Cyclopentane
	Refrigeration method	Passive cooling	Semiconductor active refrigeration	Semiconductor active refrigeration	Semiconductor active refrigeration	Semiconductor active refrigeration	Passive cooling
	Warmup time	3 hours [32°C ambient temperature load situation]	2 hours [32°C ambient temperature load situation]	2 hours [32°C ambient temperature load situation]	2 hours [32°C ambient temperature load situation]	2 hours [32°C ambient temperature load situation]	6 hours [43°C ambient temperature load situation]
	Shell/liner	ABS/ABS	ABS/aluminium plate	ABS/aluminium plate	ABS/aluminium plate	ABS/aluminium plate	HDPE/HDPE
	Alarm	Low Battery	High temperature, sensor error, power off	High temperature, sensor error, power off	High temperature, sensor error, power off	High temperature, sensor error, power off	/
	Battery	Lithium Battery	Rechargeable lithium battery	Rechargeable lithium battery	Rechargeable lithium battery	Rechargeable lithium battery	Button battery

Product appearance and specifications are subject to change without notice

Transport Cooler for the Infectious Material

The virus is high-risk specimen, and if there is collision during the transportation or transmission, there will be a risk of leakage and re-infection. A solution is urgently needed to ensure the viability of the samples and the safety of transport personnel.

Packaging System

Three-layer packaging:

- **Main container**
Test tube with cap (user configures according to business)
- **Auxiliary container**
≥95kPa pressure sealed tank (EPS or EPE bracket for fixing test tube, 16 hole D10 test tube + 2 hole D15 test tube)
- **Outer packaging**
Transfer box (ice row, foam used to fix sealed container, activated carbon and other adsorbed substances, sample labeling)

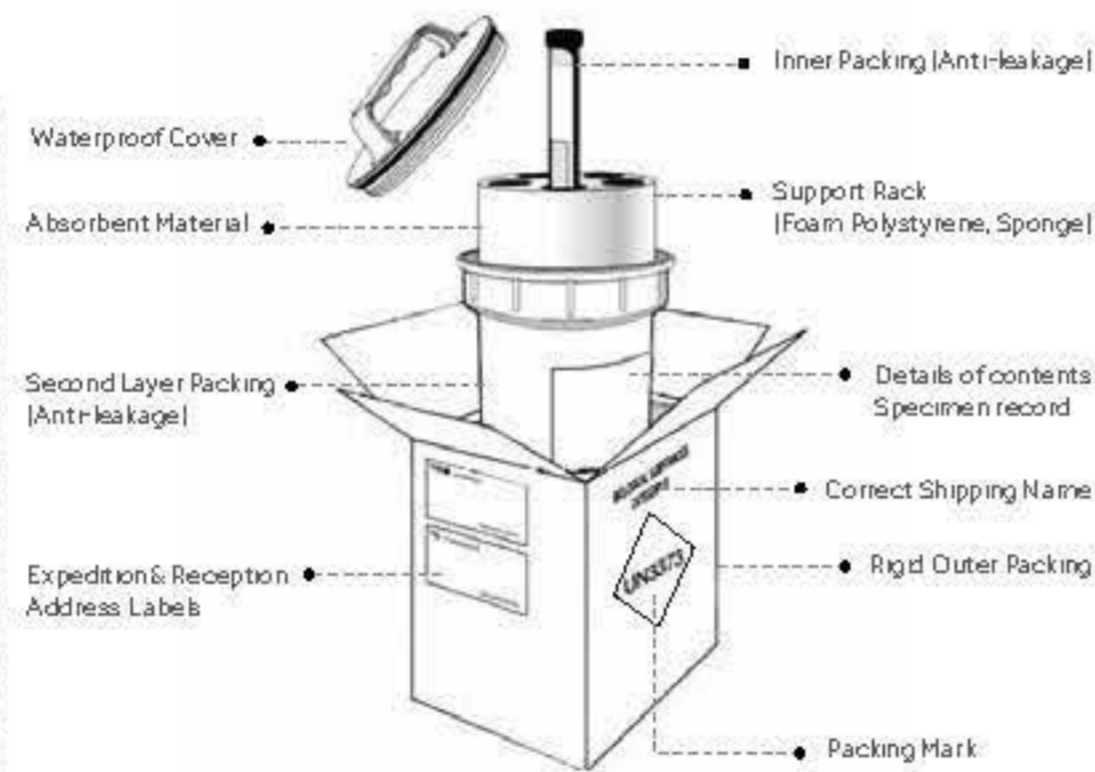

Active Cooling →



HZY-8Z (Specimen)



HZY-15Z (Specimen)

Product Advantages

- Active semiconductor cooling, energy saving and environment friendly**
 Active semiconductor cooling, energy saving and environmental protection, built-in cooling function, cooling after power on.
- Precise temperature control**
 Precise temperature control at 2°C - 6°C is suitable for the temporary storage of biological products such as serum and blood specimens.
- Built-in, 4°C phase change PCM, ice row cooling, long-term insulation after power failure, to ensure the safety of specimen**
 Under the condition of no load at 25°C, the temperature of the air in the box rises to 10°C + takes 1 hour; under the loading condition of 25°C, the air temperature in the box rises to 10°C + takes 2 hours.
- Multiple fault alarms, safer to use**
 High and low temperature alarm, power failure alarm, sensor failure alarm.
- The power supply is equipped with a car cigarette lighter plug, which is convenient for vehicle transport**
 The power supply can support 12V and 220V conversion, so the container can be put into the car to plug in and transfer.

Auxiliary Container →



HZY-8Z (Specimen)



HZY-15Z (Specimen)



Pressure sealed tank (EPS or EPE holder for fixing test tubes, 16-hole D10 test tube + 2-hole D15 test tube)

The pressure-sealed tank remains intact at the temperature of the refrigerant used, as well as the temperature and pressure that may occur after loss of refrigeration. Under the condition of no leakage, it can withstand the internal pressure of 95kPa, and can ensure that it will not be damaged in the temperature range of -40°C to +55°C.

Passive Cooling



UN2814 transport cooler
HZY-10B (P620)



UN3373 transport cooler
HZY-10B (P650)

Product Advantages



Passive cooling, long heat preservation time, suitable for air transportation;
At 32°C ambient temperature, the temperature inside the box (pre-cooled in advance) rises to 10°C+ take 7 hours(P650) and 8 hours(P620) separately.



PCM ice row, frozen at 4°C, to ensure the safety of specimen storage;



The shell is made of aluminum-magnesium alloy, with high strength; Meeting the P620 packaging requirements of Class A infectious substances(HZY-10B) and the P650 packaging requirements of Class B infectious substances(HZY-10B) separately.

Auxiliary Container



HZY-10B (P620)



HZY-10B (P650)



Pressure sealed tank (EPS or EPE holder for fixing test tubes, 16-hole D10 test tube + 2-hole D15 test tube)

The pressure-sealed tank remains intact at the temperature of the refrigerant used, as well as the temperature and pressure that may occur after loss of refrigeration. Under the condition of no leakage, it can withstand the internal pressure of 95kPa, and can ensure that it will not be damaged in the temperature range of -40°C to +55°C.

Specifications

Model	HZY-8Z	HZY-15Z
Use	Transfer of biological specimens, etc	Transfer of biological specimens, etc
Type	Active cooling, portable	Active cooling, portable
Internal dimensions (W*D*H mm)	230*140*170	430*150*180
External dimensions (W*D*H mm)	320*265*260	520*300*270
Loading quantity	1 transport tank	2 transport tanks
Effective volume	6L, 1 built-in specimen seal can	12L, 2 built-in specimen seal cans
Specimen seal can dimension (mm)	H160*D130	H160*D130
Tube storage capacity	16 pcs D10 test tubes (small), 2 pcs D15 test tubes (large)	
Net weight (kg)	3.5	6
Controller	Microprocessor control	Microprocessor control
Temporary storage temperature (°C)	2-6	2-6
Transfer temperature (°C)	2-10	2-10
Holdover time (25°C, no load) (h)	1	1
Holdover time (25°C, full load) (h)	2	2
External material	ABS, high-density EPS foam filling	ABS, high-density EPS foam filling
Internal material	Aluminum plate	Aluminum plate
Door material	ABS, high-density EPS foam filling	ABS, high-density EPS foam filling
Cold storage	PCM ice-pack for cold storage	PCM ice-pack for cold storage
Cooling type	Optimized semiconductor cooling	Optimized semiconductor cooling
Cooling fan	ADDA fan	ADDA fan
Temperature control and display	Microprocessor control, dual sensors for control and display, display accuracy 0.1 °C	
Alarms	Sensor failure alarm, high temperature alarm, power failure alarm	
Warranty	One year on complete machine	

Specifications

Model	HZY-10B (P620)	HZY-10B (P650)
Purpose	Disease control centers, hospitals, etc. are used for transport of infectious substance specimens (air transportation)	Disease control centers, hospitals, etc. are used for transshipment of Class B infectious substance specimens (air transportation)
Type	Passive cooling	Passive cooling
Internal dimensions (W*D*H mm)	345*225*182	345*225*182
External dimensions (W*D*H mm)	430*312*272	430*312*272
Loading quantity	2 transport tanks	2 transport tanks
Effective volume	14L with 2 built-in specimen sealed tanks	14L with 2 built-in specimen sealed tanks
Specimen sealed tank size (mm)	H160*D130	H160*D130
Number of test tubes (Single tank)	16 test tubes D10 (small), 2 test tubes D15 (large)	16 test tubes D10 (small), 2 test tubes D15 (large)
Net weight (kg)	8	4
Transport temperature (°C)	2-10	2-10
Thermal insulation time (32°C full load) (h)	8	7
Cabinet material	Aluminum magnesium alloy box shell	PP plastic
Thermal insulation material	EPP foam liner	EPP foam liner
Cool storage mode	PCM ice pack cold storage	PCM ice pack cold storage

Scope of Application

Temperature Sensitive Medicines Transportation Flow



Vaccines Transportation Flow

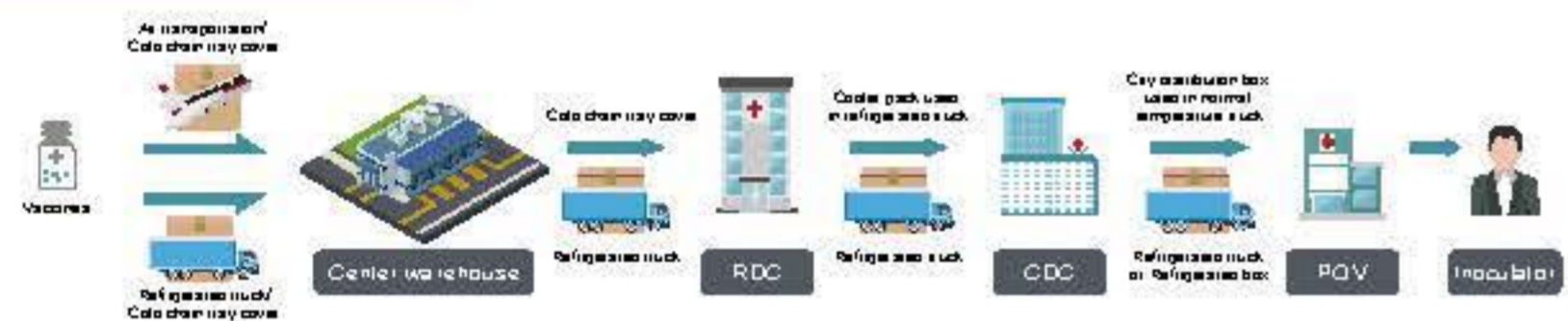

Passive Cooling

Product Advantages

High Stability and Durable

Adopting Vacuum Insulation Panel (VIP) insulation technology. The insulating material is vapor phase silica, which has an insulation performance of 5-8 times that of polyurethane foam. Vapor phase silica V.I.P. has a longer service life than other insulating materials.

Phase Change Cool Storage Technology Utilized to Reduce CO₂ Emissions

Adopting multi-temperature zone Phase Change Material (PCM), and with different phase change points, this product achieves temperature control within -25~-15°C, 2~8°C, 15~25°C and other multi-temperature zones, effectively decreasing CO₂ emissions, reduces waste and costs.

Light Weight, Easy to Carry

Designed for less-than-carload logistics and small batch logistics, light and ergonomic, easy to carry.

Extended Heat Preservation Time, Adapts to Complicated and Changeable Transportation Conditions

Superior heat preservation and cool storage capacity to ensure long-term heat preservation time to cope with the changing transportation environment.



BW25-8/12/18/36/64 BW50-12/36

Specifications

Model	BW25-8	BW25-12	BW50-12	BW25-18	BW25-36	BW50-36	BW25-64
Temperature Range	2~8°C	-25~-15/2~8/15~25°C	-25~-15/2~8/15~25°C	2~8°C	-25~-15/2~8/15~25°C	-25~-15/2~8/15~25°C	-25~-15/2~8/15~25°C
Coolant Type	PCM	PCM	PCM	PCM	PCM	PCM	PCM
Duration	48h	48h	72h	48h	72h	120h	72h
Volume	8L	12L	12L	18L	36L	36L	64L
Payload Size [W*D*H mm]	287*190*190	245*245*245	245*245*245	345*245*245	345*345*345	345*345*345	415*415*415
Outer Dimension [W*D*H mm]	436*295*500	395*350*355	448*405*410	495*350*355	495*450*455	548*505*510	564*521*526
Temperature Recorder	Optional	Optional	Optional	Optional	Optional	Optional	Optional
Product Series	Backcarry/ Carry	Carry	Carry	Backcarry/ Carry	Carry	Carry	Carry

Remarks: Data from laboratory, right to interpret by Haier Biomedical

Active Cooling

Product Advantages

DC Frequency Conversion Technology

DC frequency conversion compressor, superior energy efficiency.

Tilt Protection Function

Electronic gyroscope in board, effective protection for compressors.

Integrated Main Body

Rotational molding body better adapted to complex transport environments.

Multiple Power Supply

Supports AC and DC power.



HZY-40Z

Unique Designs

- The body and door use integrated rotomolding.
- Using environmental LBA CFC-free foaming materials, thermal insulation performance is increased by up to 5%.
- The body is equipped with a handle for easy carry.
- Optional: Casters to facilitate transport.
- Optional: Electromagnetic lock, with password lock equipped; more secure.
- Forced air cooling method, the temperature is more uniform.
- Built-in UVC ultraviolet lamp for regular disinfection.
- 3 in 1 wide temperature range, multiple functions within one unit, greater cost savings.

Specifications

Model	Exterior Dimension [W*D*H mm]	Interior Dimension [W*D*H mm]	Valid Volume	Door	Foam Materials	Compressor	Shelf/Basket/ Load bearing	Cooling Method	Outer Shell/ Inner Liner	Condenser/ Evaporator
HZY-40Z	800*550*905	377*348*285	40L	Rotational moulding integrated forming foam door	LBA	DC variable frequency compressor	Baskets:35kg	Forced air cooling	Rotational moulding	Microchannel/ Fin type

Temperature Control Method	Refrigerant	Lamp	UV Lamp	Net Weight	Temperature Range	Rated Power	Rated Power /Current	Power Consumption	Electromagnetic Lock	USB
Microprocessor	R134a	LED1W	UVC1W	25Kg	-20to 22°C	AC99-264V 50/60HZ DC12V/DC24V	85W	1.5Kwh/24h	Optional coded lock	Optional

Vaccine Storage Solution

Haier Smart Vaccine

Biomedical developed the Smart Vaccination Solution, by improving the conventional vaccination process, adopting advanced refrigeration technology, automation and intelligent vaccine delivery by incorporating IoT technologies. By connecting and leveraging the existing digital outpatient service system, the vaccination process can be managed as follows:

- After the vaccination record is scanned, the IoT based vaccination refrigerator will automatically and immediately eject the required vaccine.
- A 'double check' scan of the medical code to confirms a "Correct" & "Valid" vaccine prior to patient administration.
- Standardised vaccination process produces zero error.
- The vaccination records will be uploaded in real-time to the system. Records are traceable, making it possible to trace a specific vaccine code back to a specific child.

Smart Vaccine Safe Vaccination Solution

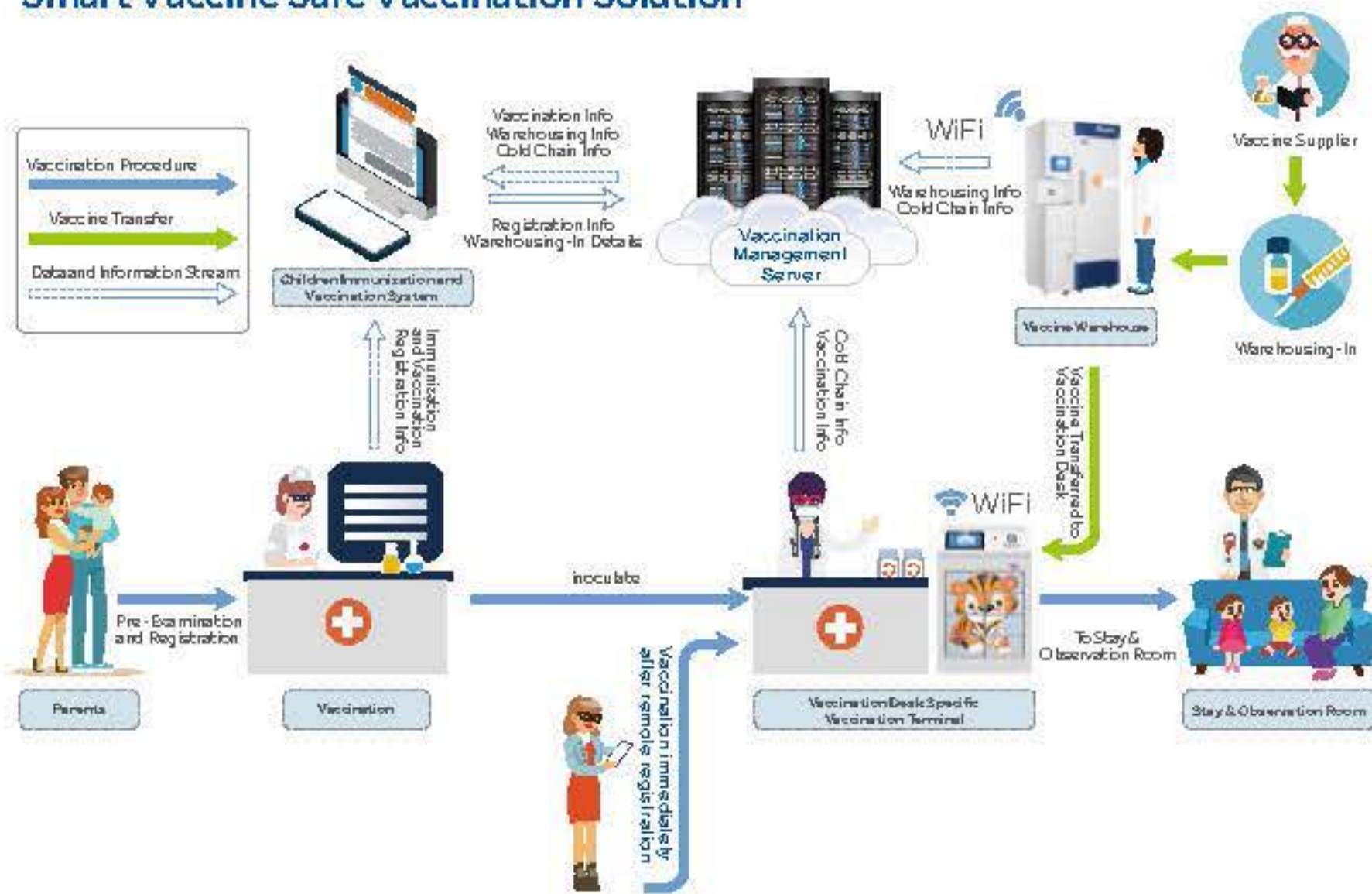

Safe, Worry-free and Intelligent Vaccine Management

3 Key Advantages

- Right patient-vaccine information management system (VIMS) confirms correct patient required for the vaccination
- Right vaccine-vaccine is automatically selected and delivered and double-checked by VIMS to ensure right medicine can and should be administered
- Exchange of vaccine, child and vaccination information, end-to-end visibility and transparency, plus immediate freezing of vaccines upon expiration or in question, ensure the high reliability of the vaccination programme.

Smart Vaccine Refrigerator

Smart Vaccine Storage Solution

Vaccine storage management is an essential step to ensure vaccine safety. However, most of the vaccine storage refrigerators used by the vaccination stations are household refrigerators or ordinary medical refrigerators, without storage management functions, making it difficult to operate a first-in-first-out methodology. Haier's intelligent vaccine preservation refrigerator solves the problem of manual (pen and paper) vaccine management, which is time-consuming and laborious.

Smart Vaccine Refrigerator

Smart Vaccine Preservation Refrigerator and Smart Vaccination Refrigerator are provided with a VIMS (Vaccine Information Management System) software to improve the vaccination experience.

- 1 Smart Vaccine Preservation Refrigerator can improve the work efficiency of nurses by removing manual inventory-taking and warehouse operations by leveraging the classification based storage, electronic regulatory code based management, data and information stream management.

 <p>HYC-361</p>	<p>Classification based storage</p> <p>Each standard refrigerator is provided with 21 compartments in 7 bays. Each compartment can distinguish different bits of vaccines by applying specific first-in-first-out rules. Different kinds of vaccines can be stored up on such classification to effectively reduce the errors during the warehousing-in/out operations.</p>	<p>The smallest package units</p> <p>The warehousing-in/out operations are verified based on the electronic regulatory codes to realize the full digitalization and automation of vaccine management, and guarantee the accuracy and reliability of vaccine storage data.</p>	<p>Data and information streams</p> <p>The data can be synchronized quickly between the vaccine warehouse and the vaccination management program. The vaccination management server utilizes the vaccination management server to monitor in real-time the vaccines stored by each vaccination station/casine.</p>
---	--	--	---

- 2 The Smart Vaccination Refrigerator, used at vaccination stations, can reduce the workload of nurses during the dispensing and checking of vaccines. The automated accurate vaccine dispensing, minimum temperature fluctuation, reconfirmation of vaccine information, electronic information system, integrated nurse station and other functions ensure zero vaccination error.

 <p>HYC-61</p>	<p>Automated accurate vaccine dispensing</p> <p>The vaccine will be ejected automatically after the vaccination record is scanned; The Regulatory Code will be scanned automatically to reconfirm the information of vaccine, including the inventory, expiration date and combination safety warning. The time of dispensing can be shortened, and the rate of vaccination errors can be reduced effectively.</p>	<p>Reduce temperature fluctuation</p> <p>The refrigerator is divided into 8 independent chambers, and the size of each chamber can be opened for taking out the vaccine required as quick as possible, to minimize the door opening time. The intelligent temperature fluctuation can be minimized to ensure the safe storage of vaccines.</p>	<p>A Double Check</p> <p>The warehousing-in/out and dispensing of vaccines can be verified by using the electronic regulatory codes. The vaccination can be conducted only after the vaccine to be used is verified by scanning the code. This function can guarantee the accurate vaccination effectively.</p>	<p>Integrated nurse workstation</p> <p>The queue management, vaccination management, vaccination information input, real-time cold chain control and authentication management are integrated into the vaccination desk vaccine refrigerator. Multiple tasks are centralized to streamline the overall management.</p>
---	---	---	--	---

Specifications

Model		HYC-361	HYC-361 Scanner Cabinet	HYC-61	
Technical Data	Cabinet Type	upright	upright	upright	
	Climate Class	N	N	N	
	Cooling Type	Forced Air Cooling	/	Forced Air Cooling	
	Defrost Mode	Manual+ Auto defrost	/	Manual+ Auto defrost	
	Refrigerant	R600a	/	R600a	
	Sound Level (dB(A))	≤41	/	≤41	
Performance	Temperature Range (°C)	2-8	/	2-8	
	Controller	Microprocessor	/	Microprocessor	
Control	Display	/	10.1 inch touch screen	10.1 inch touch screen	
Electrical Data	Power Supply (V/Hz)	220/50	/	220/50	
	Power (W)	254	/	230	
	Electrical Current (A)	1.6	/	1.5	
Dimensions	Capacity (L/Cu.Ft)	361	/	61	
	Net/Gross Weight (approx)	kg	116/139	36/42	80/90
		lbs	255.2/308.8	79.2/92.4	176/198
	Interior Dimensions (W*D*H)	mm	530*555*1380	/	560*460*630
		in	20.8*21.9*54.3	/	22*18.1*24.8
	Exterior Dimensions (W*D*H)	mm	665*710*1965	315*710*1965	600*600*935
		in	26.2*28*77.4	12.4*28*77.4	23.5*22.6*37.1
	Packing Dimensions (W*D*H)	mm	1035*805*2110	420*744*2042	660*670*1110
in		40.7*31.7*83.1	16.5*29.3*80.4	23.5*22.6*37.1	
Container load (20'/40'/40'H)		14/28/28	/	48/96/96	
Alarms	High/Low Temperature	Y	/	Y	
	Remote Alarm	Y	/	Y	
	Power Failure	Y	/	Y	
	Sensor Error	Y	/	Y	
	Low Battery	/	/	/	
	Door Ajar	Y	/	/	
Accessories	Caster	Y	/	Y	
	Foot	Y	/	Y	
	Test Hole	Y	/	/	
	Shelves/Drawers	Y	/	Y	
	USB Interface	Y	/	/	
	Temperature Recorder	/	/	/	
Others	Certification	Registration certification for medical equipment /CE	/	Registration certification for medical equipment /CE	

Product appearance and specifications are subject to change without notice



HTCD-160

Storage Security

- The anti-freeze function ensures the internal temperature of the cooling chamber is not lower than 0°C.
- Guarantees the safe storage of vaccine even in the event of a power failure. Under an ambient temperature of 43°C, the inner box temperature will be no more than 8°C after power outage for more than 121 hours and no more than 10°C after power outage for more than 160 hours.
- The freezing chamber can freeze 2.08kg of ice every day, with storage of 10.68kg in total.
- Solar powered temperature display indicates clearly the internal temperature.
- Lockable catch designed for padlock for added security
- The cooling chamber meets the A level WHO requirements for anti-freezing protection.

Temperature Control

- Microprocessor Control; accurate and precise temperature control

Ergonomic Design

- Equipped with USB charging socket, allows users to charge their mobile phone, etc.
- Eliminate storage battery and only provide solar energy power, which is better for the environment.
- Even when powered off the temperature display screen remains illuminated.
- The refrigerating chamber and freezing chamber both have separate refrigerating systems; the two independent cooling systems ensure safety of the vaccine storage.
- Sensor error alarm.
- Low noise.

Specifications

	Model	HTCD-160	
Technical Data	Cabinet Type	Upright	
	Ambient Temperature [°C]	5-43	
	Cooling Type	Direct Cooling	
	Defrost Mode	Manual	
	Refrigerant	CFC-Free	
	Noise [dB(A)]	38	
Performance	Temperature Range [°C]	Freezer ≤-10 Refrigerator: 2-8	
Control	Controller	Microprocessor	
	Display	Solar LED Temperature Display	
Electrical Data	Power Supply [V]	24	
	Maximal Current [A]	9	
	Energy Consumption: Stable Running [kWh/24h]	0.86	
	Energy Consumption: Cool Down Test [kWh/24h]	0.86	
	Holdover Time at 43°C	160hrs 8mins	
	Holdover time at 32°C	230hrs 10mins	
	Autonomy Time at 43°C	121hrs 27mins	
	Solar Radiation Reference Period [kWh/ m ² /day]	3.5	
	Voltage of Solar Panel	24V	
	Power of Solar Panel	255W*3	
Dimensions	Vaccine Storage Capacity [L/Cu.Ft]	100/3.5	
	Gross Volume [L/Cu.Ft]	Refrigerator: 120/4.2	
		Freezer: 40/1.4	
	Net/Gross Weight [approx]	kg	170/197
		lbs	374.8/434.3
	Interior Dimensions [W*D*H]	mm	Cooling Chamber: 545*500*530 Freezer Chamber: 560*520*150
		in	Cooling Chamber: 21.5*19.7*20.9 Freezer Chamber: 22.0*20.5*5.9
	Exterior Dimensions [W*D*H]	mm	865*825*1700
		in	35.1*32.6*66.9
	Packing Dimensions [W*D*H]	mm	985*920*1860
in		38.8*36.2*73.2	
Solar Panel [L*W*D]	mm	1640*990*35	
	in	64.6*39.0*1.4	
Container Load [20'/40'/40'H]		12/24/24	
Alarm	High/Low Temperature	N	
	Sensor Error	Y	
	Low Battery	-	
Accessories	Baskets	/	
	Shelves	2 [Refrigerator Room]	
Others	Certificate	CE/WHO/PQS	
	Data Logger	Y	
	Freezer Protection Level	A	
	Freezer Gross Volume [L/Cu.Ft]	40/1.4	
	Waterpack Storage Capacity [kg]	10.68	
Waterpack Freezing Capacity [kg/24h]	2.08		

Product appearance and specifications are subject to change without notice

Solar Direct Drive Combined Refrigerator/Freezer

The combined refrigerator with freezer can be used to store vaccines, reagents and freeze ice packs. Suitable for remote and sunny regions where power shortages are common.



HTCD-90

Product Features

- The refrigerating chamber and freezing chamber both have separate refrigeration systems; to ensure safe vaccine storage
- Solar direct drive is a greener and environment-friendly technology compared with traditional refrigeration
- Microprocessor control, solar powered display panel shows refrigerator and freezer interior temperature, refrigerator temperature range is 2-8°C, freezer temperature is less than -10°C
- Patented technology within the cooling chamber maintains the interior temperature, to ensure longer holding times when powered off
- Cooling chamber meets the A level WHO requirements for anti-freezing protection
- Patented technology, better temperature uniformity
- Wide working ambient range will function normally within an ambient range of 5-43°C

Ergonomic Design

- Lockable to ensure no unauthorized access
- Equipped with USB charging socket, for charging a mobile phone, etc
- Quick and efficient sample retrieval, equipped with easy-to-reach storage baskets
- Low noise
- Corrosion-resistant and easy to clean aluminium interior
- Equipped with handles on both sides of the cabinet, making it easier to move around

Solar Direct Drive Combined Refrigerator/Freezer

Specifications

	Model	HTCD-90	
Technical Data	Cabinet Type	Chest	
	Ambient Temperature [°C]	5-43	
	Cooling Type	Direct Cooling	
	Defrost Mode	Manual	
	Refrigerant	CFC-Free	
	Noise [dB(A)]	<38	
Performance	Temperature Range [°C]	Freezer ≤ -10 Refrigerator: 2-8	
Control	Controller	Microprocessor	
	Display	Solar LED Temperature Display	
Electrical Data	Power Supply [V]	24	
	Maximal Current [A]	7	
	Energy Consumption: Stable Running [kWh/24h]	0.86	
	Energy Consumption: Cool Down Test [kWh/24h]	0.81	
	Holdover Time at 43°C	137hrs 47mins	
	Holdover Time at 32°C	169hrs 6mins	
	Autonomy Time at 43°C	114hrs 56mins	
	Solar Radiation Reference Period	3.5 kWh/m ² /day	
	Voltage of Solar Panel [V]	24	
	Power of Solar Panel	180W *4	
	Dimensions	Vaccine Storage Capacity [L/Cu.Ft]	37.5/1.3
Gross Volume [L/Cu.Ft]		Refrigerator: 58/2.1	
		Freezer: 32/1.1	
Net/Gross Weight [approx]		kg	83/113
		lbs	183.0/250.0
Interior Dimensions [W*D*H]		mm	Cooling Chamber: 270*345*555
			Freezer Chamber: 170*370*575
		in	Cooling Chamber: 10.6*13.6*21.9
			Freezer Chamber: 6.7*14.6*22.6
Exterior Dimensions [W*D*H]		mm	1128*720*875
	in	44.4*28.3*34.3	
Packing Dimensions [W*D*H]	mm	1190*770*1080	
	in	46.9*30.3*42.5	
Solar Panel [L*W*D]	mm	1335*990*40	
	in	52.6*39.0*1.6	
Alarms	Container Load [20'/40'/40'H]	26/56/56	
	High/Low Temperature	N	
	Sensor Error	Y	
Accessories	Low Battery	-	
	Baskets	4	
Others	Shelves	-	
	Certificate	CE/WHO/PQS	
	Data Logger	Y	
	Freezer Protection Level	A	
	Freezer Gross Volume [L/Cu.Ft]	32/1.1	
	Waterpack Storage Capacity [kg]	12.52	
Waterpack Freezing Capacity [kg/24h]	2.43		

Product appearance and specifications are subject to change without notice

Solar Direct Drive Vaccine Refrigerator

This product is designed to store vaccine, reagents, etc. in remote, sunny regions liable to power shortages.



Product Features

- Solar direct drive, a greener and more environment-friendly technology than traditional refrigeration
- Microprocessor control, solar powered display panel shows interior temperature
- Patented technology maintains interior temperature, with longer holding times when power is off
- Cooling chamber meets the A level WHO requirements for anti-freezing protection
- Patented technology ensures better temperature uniformity
- Inner lid configuration offers additional temperature protection
- Wide working ambient range will function normally within an ambient range of 5-43°C

Ergonomic Design

- Lockable to ensure no unauthorized access
- Equipped with USB charging socket, for charging a mobile phone, etc
- Quick and efficient sample retrieval, equipped with easy-to-reach storage baskets
- Low noise
- Corrosion-resistant and ease to clean aluminium interior
- Equipped with handles on both sides of the cabinet, making it easier to move around

Solar Direct Drive Vaccine Refrigerator

Specifications

Model	HTC-40	HTC-110	HTC-112
Technical Data			
Cabinet Type	Chest	Chest	Chest
Ambient Temperature [°C]	5-43	5-43	5-43
Cooling Type	Direct Cooling	Direct Cooling	Direct Cooling
Defrost Mode	/	/	/
Refrigerant	CFC-Free	CFC-Free	CFC-Free
Noise [dB(A)]	<30	<30	<30
Performance			
Temperature Range [°C]	2-8	2-8	2-8
Control			
Controller	Microprocessor	Microprocessor	Microprocessor
Display	SolarLED Temperature Display	SolarLED Temperature Display	SolarLED Temperature Display
Electrical Data			
Power Supply [V]	24	24	24
Maximal Current [A]	5	5	5
Energy Consumption: Stable Running [kWh/24h]	0.69	0.58	0.59
Energy Consumption: Cool Down Test [kWh/24h]	0.71	0.62	0.62
Holdover Time at 43°C	122hrs 18mins	106hrs 17mins	-
Holdover Time at 32°C	163hrs 36mins	152hrs 28mins	145hrs 29mins
Autonomy Time at 43°C	117hrs 18mins	96hrs 24mins	92hrs 46mins
Solar Radiation Reference Period [kWh/m²/day]	3.5	3.5	3.5
Voltage of Solar Panel [V]	24	24	24
Power of Solar Panel [W]	180 *2	180 *2	180 *2
Dimensions			
Vaccine Storage Capacity [L/Cu.Ft]	22.5/0.8	59/2.08	75/2.65
Gross Volume [L/Cu.Ft]	40/1.4	110/3.88	110/3.88
Net/Gross Weight [approx]	kg	57/82	75/105
	lbs	125.6/180.7	165/231.5
Interior Dimensions [W*D*H]	mm	200*345*575	545*345*575
	in	7.9*13.6*22.6	21.5*13.6*22.6
Exterior Dimensions [W*D*H]	mm	788*720*875	1128*720*875
	in	31.0*28.3*34.4	44.4*28.3*34.4
Packing Dimensions [W*D*H]	mm	850*770*1080	1190*770*1080
	in	33.4*30.3*42.5	46.9*30.3*42.5
Solar Panel [L*W*D]	mm	1335*990*40	1335*990*40
	in	52.6*39.0*1.6	52.6*39.0*1.6
Container Load [20'/40'/40'H]		36/78/78	26/56/56
Alarms			
High/Low Temperature	N	N	N
Sensor Error	Y	Y	Y
Low Battery	-	-	-
Accessories			
Baskets	2	4	4
Shelves	-	-	-
Others			
Certificate	CE/WHO/PQS	CE/WHO/PQS	CE/WHO/PQS
Data Logger	Y	Y	Y
Freezer Protection Level	A	A	A
Freezer Gross Volume [L/Cu.Ft]	-	-	-
Waterpack Storage Capacity [kg]	-	-	-
Waterpack Freezing Capacity [kg/24h]	-	-	-

Product appearance and specifications are subject to change without notice



Lock Catch Designed to Match Padlock

Handgrip

Display Panel

Product Features

Solar Energy Driven

- Solar power is green and environmentally friendly

Anti-Freeze

- A level protection ensures required internal temperature

Ergonomic Design

- Easy to clean and corrosion proof

Environmentally Friendly

- Ecofriendly product

Patented Technology

- Heat-pipe provides better temperature uniformity

Specifications

	Model	HTC-120	HTC-240	
Technical Data	Cabinet Type	Upright	Upright	
	Ambient Temperature [°C]	-	-	
	Cooling Type	Direct Cooling	Direct Cooling	
	Defrost Mode	No electric heating frost	No electric heating frost	
	Refrigerant	HC	HC	
	Noise [dB(A)]	≤43	≤43	
Performance	Temperature Range [°C]	2-8	2-8	
Control	Controller	Microprocessor	Microprocessor	
	Display	Solar LED temperature display	Solar LED temperature display	
Electrical Data	Power supply [V]	24	24	
	Maximal Current [A]	5	5	
	Energy Consumption: stable running [KWh/24h]	0.44	0.35	
	Energy Consumption: cooldown test [KWh/24h]	0.48	0.54	
	Holdover time at 43°C	-	-	
	Holdover time at 32°C	112hrs 24mins	95hrs 23mins	
	Autonomy Time	183hrs 20mins	151hrs 10mins	
	At a Solar Radiation Reference Period of [KWh/m ² /day]	3.5	3.5	
	Voltage of Solar Panel [V]	24	24	
	Power of Solar Panel [W]	360	360	
Dimensions	Vaccine Storage Capacity [L/Cu.Ft]	100/3.5	200/7.1	
	Gross Volume [L/Cu.Ft]	120/4.2	240/8.5	
	Net/Gross Weight [approx]	kg	130/160	150/185
		lbs	286/352	330/407.9
	Interior Dimensions [W*D*H]	mm	530*500*530	530*500*960
		in	20.9*19.7*20.9	20.9*19.7*37.8
	Exterior Dimensions [W*D*H]	mm	865*825*1422	865*825*1815
		in	34*32*56	34*32*71
	Packing Dimensions [W*D*H]	mm	980*920*1585	985*920*1980
		in	38.8*36.2*62.4	38.8*36.2*78
Solar Panel [L*W*D]	mm	1580*808*40	1580*808*40	
	in	62.2*31.8*1.6	62.2*31.8*1.6	
Container Load [20'/40'/40'H]		12/24/24	12/24/24	
Functions	High/Low Temperature	Y	Y	
	Sensor Error	Y	Y	
	Low Battery	-	-	
Accessories	Baskets	-	-	
	Shelves	2	4	
Others	Certification	CE, PQS	CE, PQS	
	Data Logger	Y	Y	
	Freezer Protection Level	A	A	
	Freezer Gross Volume [L/Cu.Ft]	-	-	
	Waterpack Storage Capacity [kg]	-	-	
	Waterpack Freezing Capacity [kg/24h]	-	-	
	Optional	-	-	

Product appearance and specifications are subject to change without notice

This product can be used to freeze ice packs in remote and sunny regions where power shortages are common.



HTD-40

Product Features

- Environmentally-friendly solar powered drive system
- Solar-powered display panel
- High performance refrigeration system
- Rated for up to 43°C ambient
- Efficient insulation layer for temperature preservation

Ergonomic Design

- Safety lock for unauthorized access control
- Storage basket for ease of retrieval and archival of samples
- Easy to clean, corrosion proof aluminium interior

Specifications

	Model	HTD-40	
Technical Data	Cabinet Type	Chest	
	Ambient Temperature [°C]	≤43	
	Cooling Type	Direct Cooling	
	Defrost Mode	Manual	
	Refrigerant	CFC-Free	
	Noise [dB(A)]	<30	
Performance	Temperature Range [°C]	<-10	
Control	Controller	Microprocessor	
	Display	Solar LED Temperature Display	
Electrical Data	Power Supply [V]	24	
	Maximal Current [A]	5	
	Energy Consumption: Stable Running [kWh/24h]	0.46	
	Energy Consumption: Cool Down Test [kWh/24h]	0.93	
	Holdover Time at 43°C	-	
	Autonomy Time	-	
	Solar Radiation Reference Period [kWh/m²/day]	3.5	
	Voltage of Solar Panel [V]	24	
	Power of Solar Panel [W]	180*2	
	Vaccine Storage Capacity [L/Cu.Ft]	-	
Dimensions	Gross Volume [L/Cu.Ft]	48/1.7	
	Net/Gross Weight [approx]	kg	65/85
		lbs	143.0/187.4
	Interior Dimensions [W*D*H]	mm	265*370*575
		in	10.4*14.6*22.6
	Exterior Dimensions [W*D*H]	mm	788*720*875
		in	31.0*28.3*34.3
	Packing Dimensions [W*D*H]	mm	850*770*1080
		in	33.4*30.3*42.5
Solar Panel [L*W*D]	mm	1335*990*40	
	in	52.6*39.0*1.6	
Container Load [20'/40'/40H]		36/78/78	
Alarms	High/Low Temperature	N	
	Sensor Error	Y	
	Low Battery	-	
Accessories	Baskets	2	
	Shelves	-	
Others	Certificate	CE/WHO/PQS	
	Data Logger	-	
	Freezer Protection Level	1	
	Freezer Gross Volume [L/Cu.Ft]	48/1.7	
	Waterpack Storage Capacity [kg]	16.8	
	Waterpack Freezing Capacity [kg/24h]	2.4	

Product appearance and specifications are subject to change without notice

Solar Direct Drive Blood Refrigerator

Applicable for storing wholeblood, medicines, biological products and other laboratory products that need to be stored at 4°C.

Suitable for the storage of blood and blood articles in areas that have power shortages.



HTXC-240



Product Features

- Solar direct drive refrigerator without battery
- Wide applicable ambient temperature: 5-43°C
- Vertical structure, first-in first-out, easy operation
- Stainless steel drawer
- Optional RTMD
- Automatic drainage design

Solar Direct Drive Blood Refrigerator



Specifications

	Model	HTXC-240	
Technical Data	Cabinet Type	Upright	
	Ambient Temperature (°C)	≤43	
	Cooling Type	Direct Cooling	
	Defrost Mode	No electric heating frost	
	Refrigerant	HC	
	Noise (dB(A))	≤43	
Performance	Temperature Range (°C)	2-8	
Control	Controller	Microprocessor	
	Display	Solar LED temperature display	
Electrical Data	Power supply (V)	24	
	Maximal Current (A)	5	
	Energy Consumption: stable running (KWh/24h)	0.35	
	Energy Consumption: cool down test (KWh/24h)	0.54	
	Autonomy Time at 4°C	95hrs 23mins	
	Autonomy Time at 32°C	151hrs 10mins	
	At a Solar Radiation Reference Period of (kwh/m ² /day)	3.5	
	Voltage of Solar Panel (V)	24	
	Power of Solar Panel (W)	360	
	Vaccine Storage Capacity (L/Cu.Ft)	200/7.1	
Gross Volume (L/Cu.Ft)	240/8.5		
Dimensions	Net/Gross Weight (approx)	kg	150/185
		lbs	330/407.9
	Interior Dimensions (W*D*H)	mm	530*500*960
		in	20.9*19.7*37.8
	Exterior Dimensions (W*D*H)	mm	865*825*1815
		in	34*32*71
Packing Dimensions (W*D*H)	mm	985*920*1980	
	in	38.8*36.2*78	
Solar Panel (L*W*D)	mm	1580*808*40	
	in	62.2*31.8*1.6	
Container Load (20'/40'/40'H)		12/24/24	
Functions	High/Low Temperature	Y	
	Sensor Error	Y	
	Low Battery	-	
Accessories	Baskets	-	
	Shelves	4	
Others	Certification	CE, PQS	
	Data Logger	Y	
	Freezer Protection Level	A	
	Freezer Gross Volume (L/Cu.Ft)	-	
	Waterpack Storage Capacity (kg)	-	
	Waterpack Freezing Capacity (kg/24h)	-	
	Optional	Remote Temperature Monitoring Device (RTMD)	

Product appearance and specifications are subject to change without notice

The combined refrigerator with freezer can be used to store vaccines, reagents and freeze ice packs.

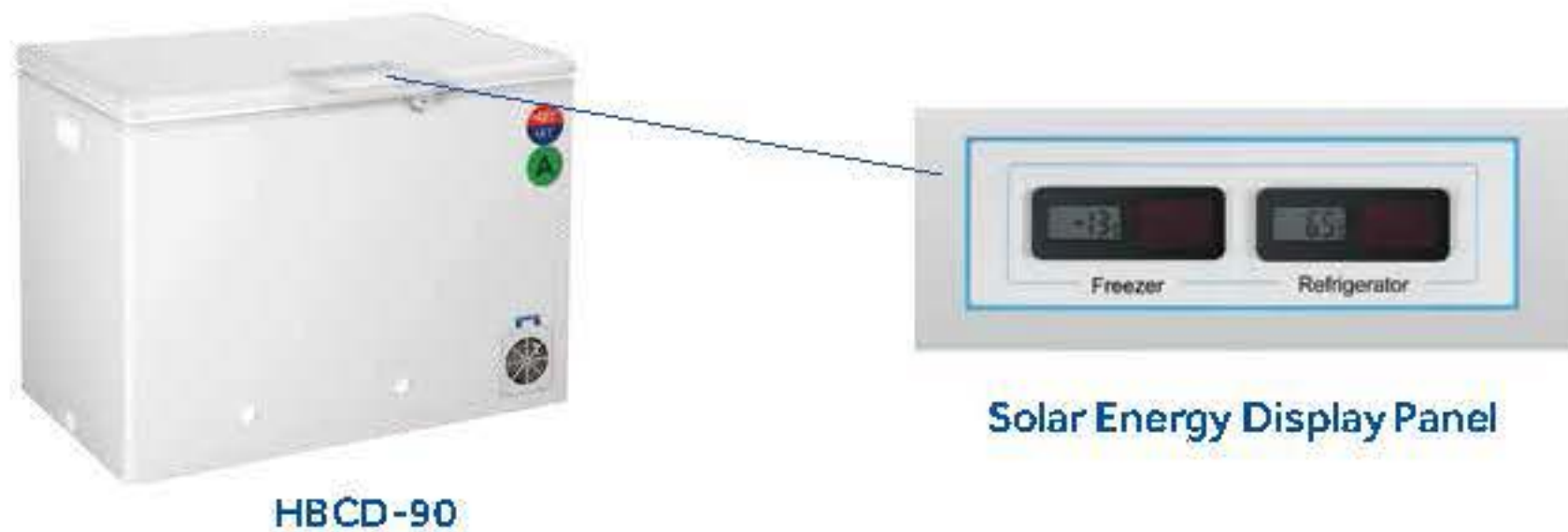

Product Features

- The refrigerating chamber and freezing chamber both have the separate refrigeration systems to ensure safe vaccine storage
- Green and environment-friendly
- Microprocessor control, solar powered display panel shows refrigerator and freezer interior temperature, refrigerator temperature range is 2~8°C, freezer temperature is less than -10°C
- Cooling chamber with water tank maintains interior temperature, extending the holding time when power is off
- Cooling chamber meets the A level WHO requirements for anti-freezing protection
- Patented technology, better temperature uniformity
- Wide working ambient range, will function normally within an ambient range of 5-43°C

Ergonomic Design

- Safety lock for unauthorized access control
- Equipped with storage basket, easy-reach retrieval of sample
- Low noise
- Aluminium and stainless steel chamber interior, corrosion-proof and easy to clean
- Equipped with handles on both sides of the cabinet, easy to move

Ice-Lined Refrigerator

Specifications

Model		HBCD-90	
Technical Data	Cabinet Type	Chest	
	Ambient Temperature [°C]	5-43	
	Cooling Type	Direct Cooling	
	Defrost Mode	Manual	
	Refrigerant	CFC-Free	
	Noise [dB(A)]	< 40	
Performance	Temperature Range [°C]	2~8	
	Freezer Protection Level	A	
Control	Controller	Microprocessor	
	Display	Solar LED Temperature Display	
Electrical Data	Power Supply [V/Hz]	220~240/50	
	Power [W]	190	
	Electrical Current [A]	1.0	
	Power Consumption: Stable Running [kWh/24h]	0.9	
	Power Consumption: Cool Down Test [kWh/24h]	1	
	Holdover Time at 43°C	63hrs 48mins	
	Holdover Time at 32°C	132hrs 21mins	
Dimensions	Vaccine Storage Capacity [L/Cu.Ft]	30/1.1	
	Gross Volume [L/Cu.Ft]	Refrigerator: 42/1.5 Freezer: 32/1.1	
	Net/Gross Weight [approx]	kg	105/135
		lbs	231/298
	Interior Dimensions [W*D*H]	mm	Refrigerator Chamber: 279*273*556 Freezer Chamber: 166*366*580
		in	Refrigerator Chamber: 11*10.8*21.9 Freezer Chamber: 6.5*14.4*22.8
	Exterior Dimensions [W*D*H]	mm	1128*717*872
		in	44.4*28.2*34.3
	Packing Dimensions [W*D*H]	mm	1190*770*1080
		in	47*30*42.5
Container Load [20'/40'/40'H]		26/56/56	
Functions	High/Low Temperature	Y	
	Power Failure	N	
	Sensor Error	Y	
Accessories	Foot/Caster	N	
	Baskets	4	
Others	Certification	CE/WHO/PQS	
	Data Logger	Y	
	Freezer Gross Volume [L/Cu.Ft]	32/1.1	
	Waterpack Storage Capacity [kg]	16	
	Waterpack Freezing Capacity [kg/24h]	4	
	Optional	30 Days Temperature Logger Automatic Voltage Stabilizer Remote Temperature Monitoring Device	

Product appearance and specifications are subject to change without notice

Refrigeration System

- Optimized refrigeration system design
- Cabinet structure designed specifically to maintain 2°C to 8°C for more than 30 hours at 43°C ambient
- CFC-free high-density foam insulation
- Complies with WHO/UNICEF standards Grade A freeze protection to ensure vaccine never freezes in the storage compartment
- Wide ambient temperature range, from 5°C -43°C

Temperature Control

- Digital solar powered temperature display
- Internal temperature range is 2°C to 8°C

Ergonomic Design

- Door lock for storage safety
- Indicator light to show whether compressors on or off status
- Independent temperature data logger to monitor, record and manage temperature records
- Operates within wide voltage range, 172-264 volts



Solar Energy Display Panel



HBC-80

Ice-Lined Refrigerator



Specifications

Model	HBC-80	HBC-150	HBC-260	
Technical Data				
Cabinet Type	Chest	Chest	Chest	
Ambient Temperature [°C]	5-43	5-43	5-43	
Cooling Type	Direct Cooling	Direct Cooling	Direct Cooling	
Defrost Mode	Auto	Auto	Auto	
Refrigerant	CFC-Free	CFC-Free	CFC-Free	
Noise [dB(A)]	<40	<40	<40	
Performance				
Temperature Range [°C]	2-8	2-8	2-8	
Control				
Controller	Microprocessor	Microprocessor	Microprocessor	
Display	SolarLED Temperature Display	SolarLED Temperature Display	SolarLED Temperature Display	
Electrical Data				
Power Supply [V/Hz]	220-240/50	220-240/50	220-240/50/60	
Power [W]	105	110	230	
Electrical Current [A]	0.9	1	1.8	
Power Consumption Stable Running [kWh/24h]	0.6	0.6	1	
Power Consumption Cool Down Test [kWh/24h]	0.7	0.7	1.1	
Holdover Time at 43°C	59hrs 58mins	60hrs 50mins	62hrs	
Holdover Time at 32°C	98hrs 26mins	96hrs 23mins	117hrs 24mins	
Dimensions				
Vaccine Storage Capacity [L/Cu.Ft]	61/2.2	122/4.3	211/7.4	
Gross Volume [L/Cu.Ft]	80/2.8	150/5.3	260/9.2	
Net/Gross Weight [approx]	kg			
	85/110	105/140	160/200	
Interior Dimensions [W*D*H]	mm	500*366*560	840*366*560	1359*366*560
	in	19.7*14.4*22	33.1*14.4*22	53.5*14.4*22
Exterior Dimensions [W*D*H]	mm	788*717*872	1128*717*872	1647*717*940
	in	31*28.2*34.3	44.4*28.2*34.3	64.8*28.2*37
Packing Dimensions [W*D*H]	mm	850*770*1080	1190*770*1080	1720*770*1080
	in	33.5*30*42.5	47*30*42.5	67.7*30*42.5
Container Load [20'/40'/40'H]		36/78/78	26/56/56	18/38/38
Functions				
High/Low Temperature	Y	Y	Y	
Power Failure	N	N	N	
Sensor Error	Y	Y	Y	
Accessories				
Foot	N	N	Y	
Baskets	2	5	9	
Others				
Certificate	CE,WHO/PQS	CE,WHO/PQS	CE,WHO/PQS	
Data Logger	Y	Y	Y	
Freezer Protection Level	A	A	A	
Optional	30 Days Temperature Logger Automatic Voltage Stabilizer Remote Temperature Monitoring Device			

Product appearance and specifications are subject to change without notice



HBC-120



HBC-240

Refrigeration System

- Optimized refrigeration system design
- Cabinet structure designed specifically to maintain 2°C to 8°C for more than 30 hours at 43°C ambient.
- CFC-free high-density foam insulation
- Complies with WHO/UNICEF standards Grade A freeze protection to ensure vaccine never freezes in the storage compartment
- Wide ambient temperature range, from 5°C -43°C

Temperature Control

- Digital Solar powered temperature display
- Internal temperature range is 2°C to 8°C

Ergonomic Design

- Door lock for storage safety
- Indicator light to show whether compressors on or off status
- Independent temperature data logger to monitor, record and manage temperature records
- Operates within wide voltage range, 172-264 volts

Ice-Lined Refrigerator

Specifications

Model		HBC-120	HBC-240	
Technical Data	Cabinet Type	Upright	Upright	
	Ambient Temperature	5 ~ 43	5 ~ 43	
	Cooling Type	Direct Cooling	Direct Cooling	
	Defrost Mode	/	/	
	Refrigerant	CFC-Free	CFC-Free	
Performance	Sound Level [dB(A)]	< 40	< 40	
	Temperature Range [°C]	2 ~ 8	2 ~ 8	
Control	Freezer Protection Level	A	A	
	Controller	Microprocessor	Microprocessor	
Electrical Data	Display	Solar LED Temperature Display	Solar LED Temperature Display	
	Power Supply [V/Hz]	220-240/50/60	220-240/50/60	
	Power [W]	145	145	
	Electrical Current [A]	1	1	
	Power Consumption: stable running [KWh/24h]	0.4	0.4	
	Power Consumption: cooldown test [KWh/24h]	0.35	0.35	
	Holdover Time at 43°C	128hrs 48mins	87hrs 14mins	
	Holdover Time at 32°C	185hrs	165hrs	
	Vaccine Storage Capacity [L/Cu.Ft]	100/3.6	200/7.2	
	Gross Volume [L/Cu.Ft]	120/4.3	240/8.5	
Dimensions	Net/Gross Weight [approx]	kg	128/160	152/186
		lbs	281.6/352	334.4/409.2
	Interior Dimensions [W*D*H]	mm	530*500*530	530*500*960
		in	20.87*19.69*20.87	20.87*19.69*37.8
	Exterior Dimensions [W*D*H]	mm	890*829*1425	890*829*1815
		in	35.04*32.64*56.10	35.04*32.64*71.46
Packing Dimensions [W*D*H]	mm	985*920*1600	985*920*2010	
	in	38.78*36.22*62.99	38.78*36.22*79.12	
Functions	Container Load [20"/40"/40"H]	12/24/24	12/24/24	
	High/Low Temperature	Y	Y	
	Power Failure	N	N	
	Sensor Error	Y	Y	
	Accessories	Foot/Caster	Y	Y
Others	Baskets/Shelves	2	4	
	Certification	CE/WHO/PQS	CE/WHO/PQS	
	Data logger	Y	Y	
	Freezer Protection Level	A	A	
Optional	30 Days Temperature Logger Automatic Voltage Stabilizer Remote Temperature Monitoring Device.			

Product appearance and specifications are subject to change without notice

The refrigerators are designed to store vaccines, freeze icepacks, pharmaceuticals etc and used within epidemic prevention, clinics, hospitals, research institutes etc.



HBD-116

Refrigeration System

- High quality compressor
- CFC-free high-density foam insulation
- Optimized refrigeration system design

Temperature Control

- Electronic temperature controller with digital display
- Internal temperature range is -15°C to -25°C

Ergonomic Design

- Safety lock to safeguard against unauthorized access
- Stainless steel interior for ease of cleaning
- Internal configuration suitable for various sizes of storage baskets
- Drainage port for ease of cabinet cleaning
- LCD temperature display

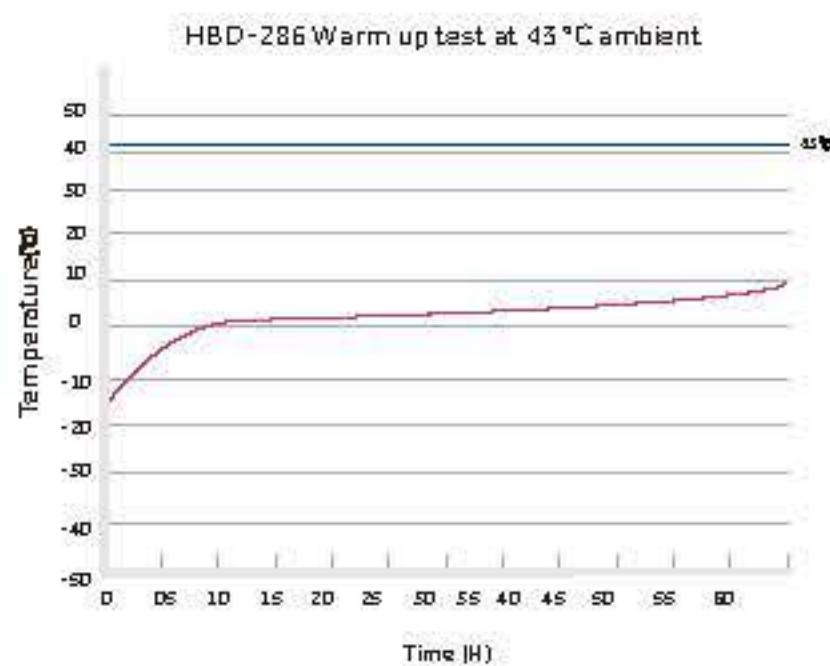
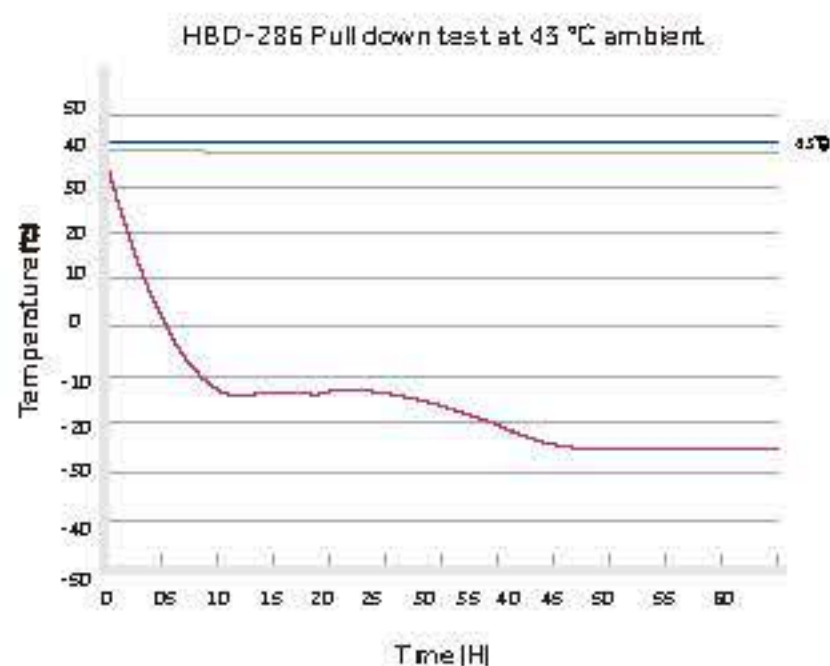

Specifications

Model		HBD-116	HBD-286	
Technical Data	Cabinet Type	Chest	Chest	
	Ambient Temperature [°C]	<43	<43	
	Cooling Type	Direct Cooling	Direct Cooling	
	Defrost Mode	Manual	Manual	
	Refrigerant	CFC-Free	CFC-Free	
	Noise [dB(A)]	43	44	
Performance	Temperature Range [°C]	-15--25	-15--25	
Control	Controller	Microprocessor	Microprocessor	
	Display	LCD	LCD	
Electrical Data	Power Supply [V/Hz]	220-240/50	220-240/50	
	Power [W]	134	185	
	Electrical Current [A]	1.1	1.3	
	Power Consumption: Stable Running [kWh/24h]	3.01	4.36	
	Power Consumption: Cool Down Test [kWh/24h]	3.77	3.77	
	Holdover Time at 43°C	More than 4hrs [up to -5°C]	More than 5hrs [up to -5°C]	
Dimensions	Vaccine Storage Capacity [L/Cu.Ft]	-	-	
	Gross Volume [L/Cu.Ft]	121/4.3	286/10.1	
	Net/Gross Weight [approx]	kg	58/67	85/97
		lbs	110.3/121.3	174.2/187.4
	Interior Dimensions [W*D*H]	mm	497*457*655	1067*457*655
		in	19.6*18.0*25.8	42.0*18.0*25.8
	Exterior Dimensions [W*D*H]	mm	670*630*915	1240*630*915
		in	26.4*24.8*36.0	48.8*24.8*36.0
	Packing Dimensions [W*D*H]	paper		paper
		mm	755*760*1005	1325*760*1005
	in	29.7*29.9*39.6	52.2*29.9*39.6	
Container Load [20/40/40 H]		42/90/90	24/50/50	
Accessories	Foot	Y	Y	
	Baskets	2	3	
Others	Certificate	CE,WHO/PQS	CE,WHO/PQS	
	Optional	Automatic Voltage Stabilizer	Automatic Voltage Stabilizer	

Product appearance and specifications are subject to change without notice



Biomedical walk-in cold rooms are for storage of vaccines and other temperature sensitive products. The complete unit is also designed for installations in housed areas such as warehouses to meet specified temperature standards. These units have been installed in India, Guinea, Syria, Pakistan, Burundi, Zimbabwe and other regions across the world.

Specifications

Type	Freezer Room	Freezer Room	Cold Room	Cold Room	Cold Room	Cold Room	Cold Room	Cold Room	Combined Cold/Freezer Room
Model	HRZK-40D	HRZK-20D	HRZK-10G	HRZK-15G	HRZK-20G	HRZK-30G	HRZK-40G		HRZK-40GD
Defrost Mode	Electrical heating								
Refrigerant	CFC-Free								
Internal Temperature Range [°C]	-20	-20	2-8	2-8	2-8	2-8	2-8	2-8	-20
Evaporator Temperature [°C]	-25	-25	-7	-7	-7	-7	-7	-7	-25
Power Supply [V/Hz]	380/50	380/50	220/50	220/50	220/50	380/50	380/50		380/50
Power [W]	5500	2650	1300	1750	1750	2520	2610	2520	2010
Refrigerating Output [W]	4200	2060	1560	2230	2230	2950	3250	2950	1560
Capacity [m ³]	40	20	10	15	20	30	40	25	15
Condensation Temperature [°C]	43								
Density [Kg/Cbm]	40±2								
K-Value [m ² K]	0.22								
Insulation Thickness [mm]	100								
Certification	-		WH-IO/PQS						

Product appearance and specifications are subject to change without notice

Walk-In Cold/Freezer Room

Integral Cold Store Unit

The cold room is suitable for a variety of applications; it can be used to freeze or refrigerate samples for healthcare, research, agriculture, and biotechnology purposes. In the walk-in cold room (WIC), the interior temperature can be controlled within a range of 2°C to 8°C. In the walk-in freezer (WIF), the temperature is set at -20°C.

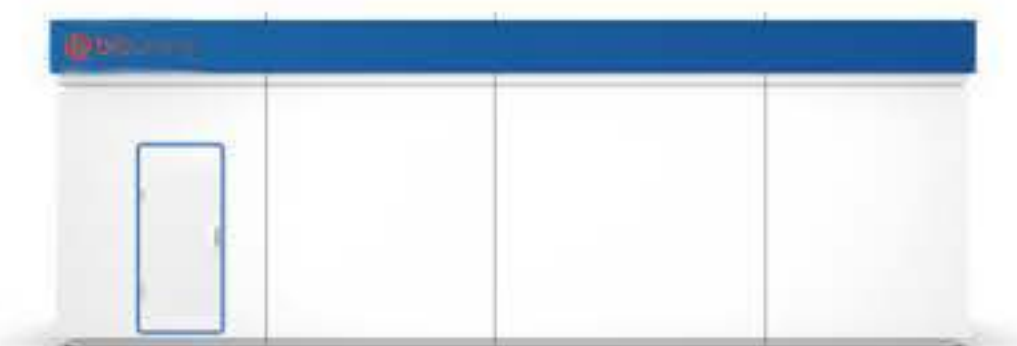

Features of the Cold Room

- The set point of the cold room has an adjustable range of 0°C to 10°C (or -15°C to -25°C for the Freezer Room) with a resolution of 0.1°C.
- High-efficiency CFC-free polyurethane insulation foamed into place. With a density of 42kg/m³, a thickness of 100mm and an insulation K-value of 0.22 W/(m²)(K) or better.
- Internal and exterior surfaces are made up of hot-dipped galvanized steel sheet, coated in a white polyester coating. The floor is clad with non-slip material.
- Rooms are equipped with tungsten lighting.
- Rooms are equipped with shelving systems on 3 of their walls.
- Dual refrigeration system – while one system is working, the other one is reserved as a back-up.
- Forced air-cooling system
- Door equipped with a lock and heavy-duty hinges, with an internal safety release.
- CFC-free refrigerant
- Automatic defrosting
- A manual change-over switch is offered as standard, an automatic change-over switch is available as an optional extra.
- Temperature recorder and audible alarm system.

Technical Characteristics of the Refrigerating Unit

- An integrated condenser unit, called Mono block, integrating evaporator, condenser, compressor, electrical control units into one compact body, is used in cold storage rooms with temperature control of -5°C-5°C or -15°C--20°C, in medical, clinical, agricultural and chemical industries where large scale cold storage is needed.
- Small compact structure.
- Comprises of TECUMSEH hermetic compressors, high efficient, in-grooved copper tube and aluminium fin heat exchangers and leading brand refrigeration parts.
- The electronic control boards manage following parameters: automatic temperature setpoint and control, electric heater defrosting, protection devices for over loading, over-heating, lack of phase, high and low pressure.
- Safe, easy to use and is economical, low cost installation and operation.

Temperature Recorder

- Upper and lower limits +50°C to -30°C
- Accuracy ±1°C
- Resolution ±0.5°C
- Minimum acceptable recording period between chart changes is 7 days
- USB interface is included

Combined Cold Room

Applicable for storing large quantities of vaccines, reagents, medicines and other biological products. Suitable for CDCs, animal epidemic prevention and control centers, hospitals, biopharmaceutical companies, etc.



Technical Features:

- The integrated solution provider integrates cold storage, automation, informatization and environmental laboratory.

Environmental protection

- Uses R404a environmentally friendly refrigerant;
- Uses durable, environmentally-friendly poly-ethurane foam insulated walls to provide excellent insulation with a low ozone destruction coefficient.

Safety

- With equipment fault self-diagnosis function. With a variety of active protection and passive early warning functions, the operating status is monitored to ensure the safety of stored samples.

Modular

- The system is modular and solutions are customized according to individual requirements.

Energy saving

- The technology of liquid-subcooling and exhaust-precooling via defrosting water is adopted to save energy.

Smart

- The PLC control system can automatically control the start and stop of the refrigeration unit, the regular switching between the main and standby machines and the automatic fault switch. No manual operation is required for refrigeration and defrosting.

Side Loading Cold Room

Applied to save vaccines, reagents, medications, biological products, etc.. Suitable for community clinics, pharmacies, etc.



Technical Features:

- All-weather: 24-hour uninterrupted monitoring of the cold storage operation status to ensure the safety of samples;

Solar Direct Driven Cold Room

- Whole process monitoring: production, transportation and storage
- Full coverage: network monitoring, real-time query, unified management
- Stable state change rate: $\leq \pm 0.3^{\circ}\text{C}/10\text{h}$
- Temperature uniformity: $\leq \pm 3^{\circ}\text{C}$
- Ultra-low noise: the noise of the outdoor unit is less than 50 decibels
- Exclusive perforated ceiling air supply design ensures rapid cooling and excellent temperature uniformity $\pm 1^{\circ}\text{C}$
- Utilizes quick and effective hot fluoride defrosting method
- An electronic expansion valve accurately controls the storage temperature while ensuring the refrigeration system runs more energy efficiently



Applicable for storage of temperature-sensitive products such as large quantities of vaccines and medicines; National or regional vaccine centers, hospitals, biopharmaceutical and other industries;

Technical Features:

- Powered by solar photovoltaic power generation system, low operating cost.

- Solar direct drive refrigeration, no battery driven compressor; combined with ice lining technology, maintain the temperature in the cold room at 2-8 °C throughout the day.
- Adopting PLC intelligent control, preferentially start the compressor of higher temperature cold storage box to ensure the uniformity of the room temperature.
- Power off and maintain 2-8°C for more than 48 hours at 43°C ambient temperature; it can last longer under low ambient temperature conditions.
- Low temperature protection function module (optional), can achieve 5-43 °C wide temperature range operation.
- Optional 48V switching power supply can be connected to single-phase 110-220V AC power supply.



30-Day Electronic Temperature Logger

bitstrong Biomedical Vaccine Cold Chain Storage Safety Solution

- Continuous, real-time, whole-process traceable monitoring for vaccine safety storage
- WHO approved and sourced by WHO procurement.

30-Day Electronic Temperature Logger



HETL-01



WHO Certified
PQS code:E006/042

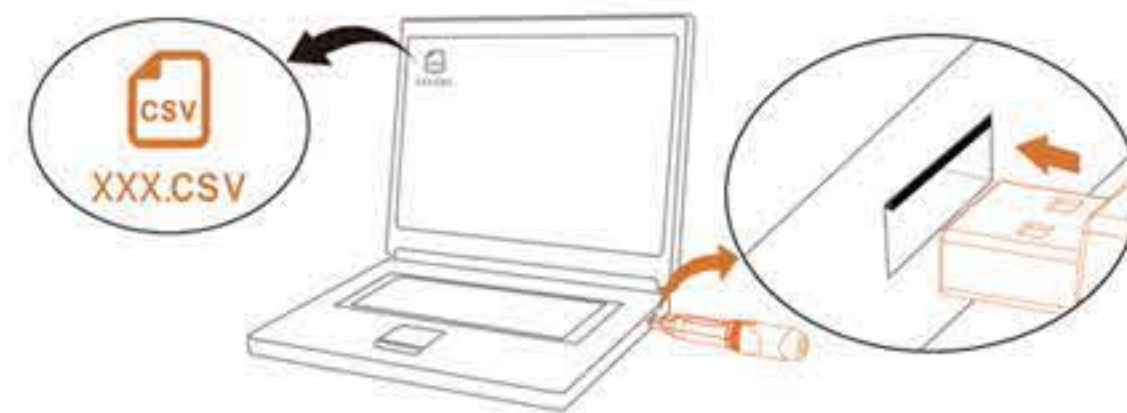

Easy to download data



Accessory: Bracket

30-Day Electronic Temperature Logger

Product Features

- Approved by WHO's PQS, PQS code:E006/042
- Designed specifically for 2-8°C vaccine storage, equipped with high/low temperature visual alarm to meet the WHO standard
- Recording capacity is over 30days, recording interval is 6 minutes, outdated data will be overwritten by new one automatically, when the recording volume is full
- LCD screen displays temperature
- Integrated sensor device, dust and water resistant to IP65 protection standard, can be placed in Cold Box or vaccine refrigerator to monitor the temperature
- The logger can be plugged into the USB port of any PC to automatically generate a CSV file including temperature data and temperature graph which can be generated by data management software
- Built-in disposable wide temperature range lithium battery (Non-replaceable) with a minimum operating life of two years after a maximum shelf life of one year
- The bracket is included as standard

Specifications

Model	HETL-01
Temperature Range (°C)	-20~+50
Main Material	ABS(Transparent Shield: PC)
Data Interface	USB Interface
Display Medium	LCD
Resolution (°C)	0.1
Accuracy	±0.5°C for -20°C~+40°C, ±1°C for the others
Recording Volume	8192 Data Points(34 days)
Logging Interval	6 min
Power Source	Non-Replaceable Battery
Size (Length*Diameter mm)	131*24
Service Life	2-3 years

Product appearance and specifications are subject to change without notice



**Laboratory
Equipment**

Main Uses

The X series of standard Class II microbiological safety cabinets are suitable for basic cell biology, microbiology, biomedicine, biosafety laboratories and other laboratories. It is the most basic protection and isolation equipment for biosafety.



Product function advantages

- The dual DC fans meet the low-noise, energy-saving and high-reliability requirements
- Utilizing intelligent constant air speed design to monitor the downward airflow and the inlet airflow in real-time. The dual air speed sensors adjust the fan speed through a microcomputer system so as to maintain constant air speed inside the cabinet
- Adopting ultralow penetration air filters (ULPA) ensuring a cleanliness grade conforming to Class 1 of the American standard FED STD 209E (Class 3 of ISO14644-1) and using pressure sensors to monitor the service life of the filters in real-time to ensure superior accuracy and efficiency
- Optional - X series - electric lifting glass doors with matching foot switches
- Optional - X series - comes equipped with surveillance cameras to record the operating status of the left and right working areas respectively and independently
- Optional - Intelligent IoT module to enable the mobile App to monitor the running state of the safety cabinet and display the performance parameters such as air speed and filter life in real-time
- Adopting an intelligent interlock design to avoid the risk of misoperation; with an operational front window interlocking with the UV lamp, LED lamp and fan intelligently to ensure better security
- Patented technology one-button UV lamp timer, enabling the memory setting of the user's UV lamp usage habits for convenient one-key start-up of the UV lamp timing function

Product construction advantages

- Using platform-type hand rest racks which are comfortable to use and can relieve fatigue; with leak-proof construction to prevent the splashed liquid waste from entering into the seams of the racks
- The cabinet body has a 10-degree inclination design, which is in accordance with ergonomic principles and more comfortable to operate
- The cabinet has a pull-down front window, which makes it easy to clean the upper glass after pulling down the glass front window and removing the hand rest racks
- Equipped with an integrated workbench and a stainless steel liquid collecting tank larger than the workbench so as to prevent liquid leakage
- Constructed with a universal caster design to facilitate ease of movement by users and comes with built-in threaded feet to prevent bacterial growth
- With real-time display of the filter life and the running time of the fan and the UV lamp, the system alerts the user by alarm when the service life of the filter and the UV lamp becomes less than 10%, which is convenient and safe



Specifications

Model		HR1200-IIA2-X	HR1500-IIA2-X	HR1800-IIA2-X
Working Voltage&Frequency (V/Hz)		220/50/60	220/50/60	220/50/60
Power (VA)		1600	1670	1850
Power of Blower (W)		DC 120/112	DC 190/112	DC 120/112
Airflow Circulation		70% Downflow,30% Exhaust	70% Downflow,30% Exhaust	70% Downflow,30% Exhaust
Main Filter Typical Efficiency		ULPA ,U15,99.9995%@0.12um	ULPA ,U15,99.9995%@0.12um	ULPA ,U15,99.9995%@0.12um
Exhaust Filter Typical Efficiency		ULPA ,U15,99.9995%@0.12um	ULPA ,U15,99.9995%@0.12um	ULPA ,U15,99.9995%@0.12um
Filter's Brand		AAF	AAF	AAF
Downflow Velocity (m/s)		0.30	0.30	0.30
Inflow Velocity (m/s)		0.45	0.45	0.45
Net/Gross Weight (approx)	kg	280/340	320/400	380/465
	lbs	617/750	705/882	838/1025
Interior Dimensions (W*D*H)	mm	1230*600*655	1530*600*655	1830*600*655
	in	48.4*23.6*25.8	60.2*23.6*25.8	72.0*23.6*25.8
Exterior Dimensions (W*D*H)	mm	1336*790*2120	1636*790*2120	1936*790*2120
	in	52.6*31.1*83.5	64.4*31.1*83.5	76.2*31.1*83.5
Packing Dimensions (W*D*H)	mm	1400*925*1665	1700*925*1665	2000*925*1665
	in	55.1*36.4*65.6	66.9*36.4*65.6	78.7*36.4*65.6
Supporter		680-900mm adjustable height	680-900mm adjustable height	680-900mm adjustable height
Container load(20"/40"/40"H)		8/16/16	6/12/12	6/12/12
Alarm		Sound and Flash	Sound and Flash	Sound and Flash
Certification		CFDA,CE	CFDA,CE	CFDA,CE

Product appearance and specifications are subject to change without notice

Main Uses

These are standard Class II microbiological safety cabinets suitable for basic cell biology, microbiology, biomedicine, biosafety laboratories and other laboratories. It is the most basic protection and isolation equipment for biosafety.



Product Advantages

- HR1200-IIA2-S is the latest biosafety cabinet developed and manufactured to European Standard EN12469.
- With improved energy efficiency the HR1200-IIA2-S is equipped with two DC fans which also lower noise output.
- A highly efficient HEPA output filter provides protection for the samples, operators and environment.
- Side glass windows allow more natural light, reducing optical stress caused by artificial lighting.
- Additional features include height adjustable stand with wheels and levelling feet, air valve and vacuum valve ports.

Features

- Certified to EN12469.
- Damp-proof, fire-proof glass fibre HEPA filter with a filtering efficiency for $\geq 0.3\mu\text{m}$ particulate matter is $\geq 99.995\%$ provides cleaner air and safer samples.
- Dual DC fans allow for better air flow uniformity and operate with lower noise.
- LCD screen displays various parameters and clear operational conditions.
- UV lamp can be set with one single key to activate/deactivate automatically at specified sterilization intervals from 0min to 24hrs, to minimize the waiting time.
- The product features an interlocking function between the ultraviolet sterilization, fluorescent lamp, front window and fan motor meaning the UV lamp can only come on when the illuminating lamp is off. This failsafe removes the risk of incorrect operation.
- Multiple audible and visual alarms: hardware malfunction alarm, operating parameter overrun alarm, filter/UV lamp lifecycle ending alarm, etc.
- Two patented IP 44 rated water-proof sockets with timed on/off function for improved safety and energy conservation.
- Optional electric door or electric underframe.

Ergonomic Design

- 10° angled front window provides a comfortable work space for operators.
- Adjustable height stand with hidden mechanism to avoid contamination.
- Universal castor for convenient moving.
- Drop-down front window design for easier cleaning of the upper edge of glass.
- Removable hand rest reduces arm fatigue and does not interfere with air inflow.
- Optional accessories include water valve (manual/ electric), air valve, VHP sterilizer and electric door function (door electric motor and foot switch).

Main Uses

Energy efficient Class II microbiological safety cabinet with two DC fans, dual exhaust HEPA's and long lasting LED lights. Suitable for microbiology, biomedicine, biosafety laboratories and other laboratories. It offers three levels of protection – operator, product and environment.



Product Advantages

The HR1200-IIA2 double exhaust filtered biological safety cabinet utilises two highly efficient HEPA exhaust filters and one ULPA downflow filter to provide three levels of protection; operator, product and environment. As there is no need for external ducting, this is a cost-effective solution.

The unit is certified to the EN 12469 standard. It uses energy efficient DC fans, as well as LED lights to ensure for optimal performance with a low noise output and reduce energy consumption. The ergonomic design ensures maximum comfort and alleviates operator fatigue.

The units utilise side air design on the upper edge and on both sides of the front window to eliminate 'blind spots'. This prevents crossflow between inside and outside air thus reducing the risk of contamination. The compartmented working surface can easily be removed for sterilization and cleaning.

Features

- E.U. EN12469 Standard Certification.
- The main filter uses a damp-proof, fire-proof glass fibre ULPA filter, the filtering efficiency for $\geq 0.12\mu\text{m}$ particulate matter is $\geq 99.9995\%$ which provides cleaner air and safer samples.
- EC fan operates with lower noise and better uniformity air flow.
- LCD screen displays various parameters and clear operational conditions.
- Ultraviolet light can be set with one single key to automate on/off time, and sterilization time interval from 0 to 24 hours, reducing downtime.
- The product features an interlocking function between the ultraviolet sterilization, fluorescent lamp, front window and fan motor meaning the UV lamp can only come on when illuminating lamp is off. This failsafe removes the risk of incorrect operation.
- Equipped with multiple visual and sound alert functions, it is clear and easy to understand. Alarms include filter and UV end-of-life alerts, fan turned-off after door opening alert and door open alarm.
- Two patented IP44 rated waterproof sockets with timed on/off function to improve safety and conserve energy.

Ergonomic Design

- 10° angled front window provides a comfortable work space for operators.
- Adjustable height stands with hidden mechanism to avoid contamination.
- Universal castors with self-levelling feet for convenient moving.
- Drop-down front window design for easier cleaning of the upper edge of glass.
- Removable hand rest reduces arm fatigue and does not interfere with air inflow.
- Optional accessories include water valve (manual/electric), air valve and VHP sterilizer.
- Optional electric door or electric underframe.

Alarm Functions

- Fan turn-off alarm after door opening.
- Abnormal door height alarm.
- Door open more than limit.
- Blocked filter alarm.
- Damaged filter alert.
- Filter and UV end-of-life alert.
- Front glass blocks ultraviolet.

bitstrong Biomedical Biological Safety Cabinet is designed to protect the operator, laboratory environment and samples from being exposed to the infective aerosol produced from samples with bacteria strains, diagnostic materials, and other infective substances. It provides the operator with comfortable and safer working conditions. It is widely used in medical health, disease prevention, food safety, biological pharmacy and environment monitoring.



Features

Patent Intelligent Constant Air Velocity

The professional hot-bulb air velocity transducer performs real-time monitoring on the air velocity of the working area, compares it with the standard air velocity and maintains a constant velocity by adjustment of the fan speed by microcomputer system.

Low Noise Safety Energy-saving Mode

When the human body sensor module detects under the intelligent mode that the person is outside and away from the operating area for over 15 minutes, the microcomputer program will automatically switch the safety cabinet to Low Noise Safety Energy Conservation mode, which reduces noise, conserves energy and improves the service life of the filter.

Professional Air-flow Distribution Module

Through the professional air flow distribution design, the safety cabinet provides a more uniform airflow, reducing contamination and noise to <math><62\text{dB(A)}</math>.

Ultra Low Penetration Air Filter System

American AAF (ULPA) filter is tested to a typical efficiency of > 99.9995% for 0.12 micron particles. ULPA filter provides vertical laminar flow to the worktable to protect samples from pollution.

Patented Air Flow Disruption Technology

The units utilise side air design on the upper edge and on both sides of the front window to eliminate 'blind spots'. This prevents crossflow between inside and outside air, reducing contamination (Patent No. ZL200520125549.X).

Unique Drop-down Front Glass Window

The unique drop-down front glass window can be removed in seconds to enable quick and efficient cleaning of upper sections, shortening downtime.

Removable Arm Rest

Removable arm rest reduces user fatigue and does not interfere with air inflow.

	Biosafety Cabinets	Air Quality	Filtration	Electrical Safety
Standards Compliance	EN 12469, Europe NMPA (CFDA) YY-0569, China	ISO 14644.1, Class 3, Worldwide US Fed Std 209E, Class 1 USA	EN-1822 (H14), Europe IEST-RP-CC001.3, USA IEST-RP-CC007, USA IEST-RP-CC034.1, USA	EN61010



HR40-IIA2

304 Stainless Steel Operation Platform and Internal Wall

- Stainless steel work surface without screws ensures no accumulation of contaminant
- Removable air in-flow plate is easy to clean and disinfect
- Internal wall is constructed of a single piece stainless steel, with 12mm arc angle corners which allows for more effective cleaning
- The volume of liquid tank is over 4L, equipped with outlet valve for convenient cleaning and maintenance
- Concaved work surface, waste liquid easily collected
- Adjustable stand (0-75mm) without exposed screw thread, reduces risk of contamination



Ultra Low Penetration Air Filtration System

- American AAF ULPA filter
- Tested to a typical efficiency of 99.9995% for 0.12 micron particles
- Provides FED STD 209E class 1 (or ISO14644.1 class 3) clean air to work surface in a stable vertical laminar flow to protect samples
- The exhaust ULPA filter traps biohazard particles acquired from the work surface before air is exhausted to the room, offering personnel and environmental protection.

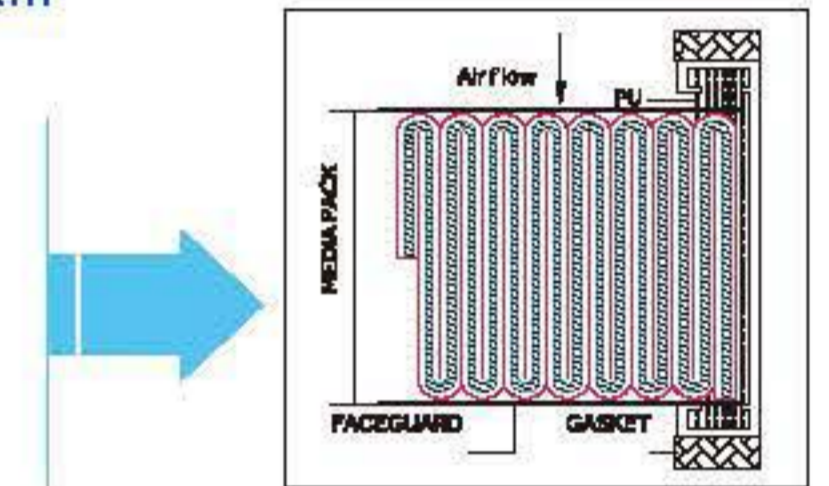

High Efficiency Blower System

- The blower system is designed for high performance operation, maximum energy efficiency and minimal maintenance
- Self cooling system reduces energy consumption while enhancing reliability

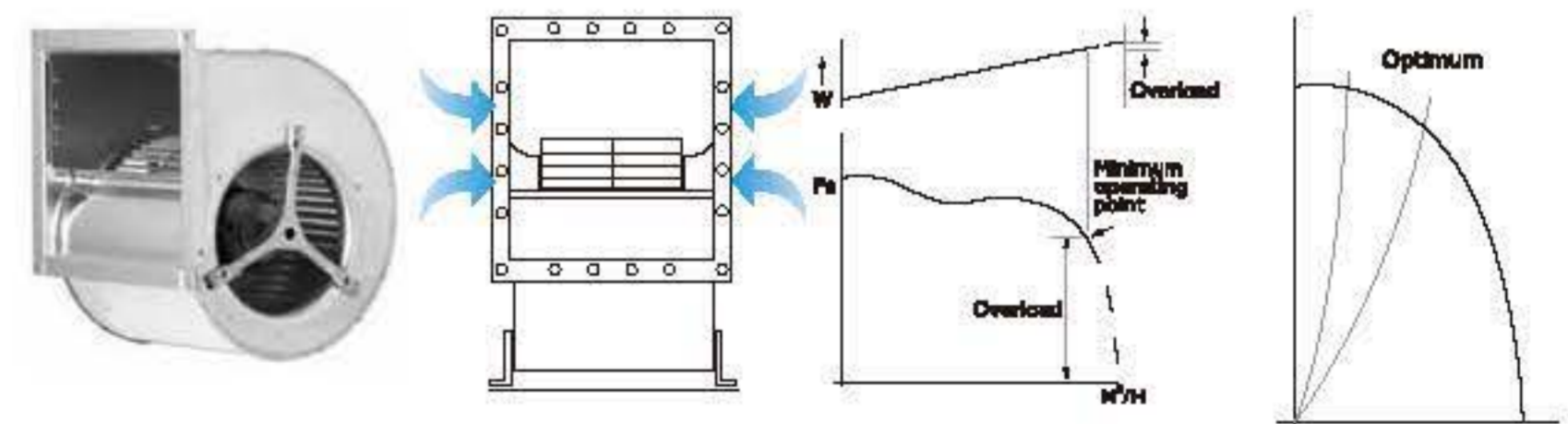

Reverse centrifugal fan	Double-side air inflow design decreases running noise	Air velocity auto-compensation function guarantees stable wind speed	Provide uniform airflow by adjusting working voltage of fan
-------------------------	---	--	---



Specifications

Model		HR900-IIA2	HR1200-IIA2	HR1200-IIA2-D	HR1200-IIA2-S	HR1500-IIA2
Working Voltage&Frequency (V/Hz)		220/50	220/50	220/50/60	220/50/60	220/50
Power (VA)		1400	1500	1600	1600	1600
Power of Blower (W)		AC-L=330W,M=465W,H=735W	AC-L=330W,M=465W,H=735W	DC 190W, DC 170W	DC 120W,DC 112W	AC 650W
Airflow Circulation		70% Downflow,30% Exhaust	70% Downflow,30% Exhaust	70% Downflow,30% Exhaust	70% Downflow,30% Exhaust	70% Downflow,30% Exhaust
Main Filter Typical Efficiency		ULPA,U15,99.9995%@0.12um	ULPA,U15,99.9995%@0.12um	ULPA,U15,99.9995%@0.12um	HEPA,H14,99.995%@0.3um	ULPA,U15,99.9995%@0.12um
Exhaust Filter Typical Efficiency		ULPA,U15,99.9995%@0.12um	HEPA,H14,99.995%@0.3um	TWO HEPA,H14,99.995%@0.3um	HEPA,H14,99.995%@0.3um	HEPA,H14,99.995%@0.3um
Filter's Brand		AAF	AAF	AAF	AAF	AAF
Downflow Velocity (m/s)		0.33	0.34	0.30	0.30	0.31
Inflow Velocity (m/s)		0.55	0.55	0.45	0.45	0.55
Fluorescent Lamp Intensity (Lux)		≥900	≥900	≥1000	≥1000	≥900
Net/Gross Weight (approx)	kg	270/293	320/339	320/339	320/339	360/393
	lbs	595.3/646	705.5/747.4	705.5/747.4	705.5/747.4	793.7/866.4
Interior Dimensions (W*D*H)	mm	920*620*650	1220*620*650	1310*620*630	1310*620*630	1520*620*650
	in	36.2*24.4*25.6	48.0*24.4*25.6	51.6*24.4*24.8	51.6*24.4*24.8	59.9*24.4*25.6
Exterior Dimensions (W*D*H)	mm	1080*845*2160	1380*845*2160	1380*780*2160	1380*780*2160	1680*845*2160
	in	42.5*33.3*85.0	54.3*33.3*85.0	54.3*30.7*85.0	54.3*30.7*85.0	66.1*33.3*85.0
Packing Dimensions (W*D*H)	mm	1145*920*1690	1470*920*1690	1470*920*1690	1470*920*1690	1755*920*1690
	in	45.1*36.2*66.5	57.9*36.2*66.5	57.9*36.2*66.5	57.9*36.2*66.5	69.1*36.2*66.5
Supporter		680-900mm adjustable height	680-900mm adjustable height	680-900mm adjustable height	680-900mm adjustable height	680-900mm adjustable height
Container load(20'/40'/40'H)		12/24/24	8/16/16	8/16/16	8/16/16	6/12/12
Alarm		Sound and Flash	Sound and Flash	Sound and Flash	Sound and Flash	Sound and Flash
Certificate		NMPA(CFDA),CE,EN12469	NMPA(CFDA),CE,EN12469	CE,EN12469	CE,EN12469	NMPA (CFDA) ,CE,EN12469

Product appearance and specifications are subject to change without notice



Biological Safety Cabinet



Specifications

Model	HR30-IIA2	HR40-IIA2	HR40-IIA2	HR40-IIB2
Working Voltage&Frequency (V/Hz)	220/50	115/60	220/50/60	220/50/60
Power (VA)	1300	1300	1300	1700
Power of Blower (W)	AC-L=330,M=465,H=735	AC 540/625	AC 540/625	AC 115
Airflow Circulation	70% Downflow,30% Exhaust	70% Downflow,30% Exhaust	70% Downflow,30% Exhaust	100% Exhaust
Main Filter Typical Efficiency	ULPA ,U15,99.9995%@0.12um	ULPA ,U15,99.9995%@0.12um	ULPA ,U15,99.9995%@0.12um	ULPA ,U15,99.9995%@0.12um
Exhaust Filter Typical Efficiency	ULPA ,U15,99.9995%@0.12um	HEPA ,H14,99.995%@0.3um	HEPA ,H14,99.995%@0.3um	HEPA ,H14,99.995%@0.3um
Filter's Brand	AirePlus	AAF	AAF	AAF
Downflow Velocity (m/s)	0.31	0.28	0.28	0.28
Inflow Velocity (m/s)	0.55	0.55	0.55	0.55
Fluorescent Lamp Intensity (Lux)	≥1200	≥1200	≥1200	≥1200
Net/Gross Weight (approx)	kg	235/257	293/316	252/298
	lbs	518.5/567.1	646.5/697.3	555.6/657.5
Interior Dimensions (W*D*H)	mm	900*610*680	1167*610*680	1167*610*680
	in	35.4*24.0*26.8	45.9*24.0*26.8	45.9*24.0*26.8
Exterior Dimensions (W*D*H)	mm	1100*790*2200	1360*790*2200	1360*790*2400
	in	43.3*31.1*86.6	53.5*31.1*86.6	53.5*31.1*94.5
Packing Dimensions (W*D*H)	mm	1155*905*1720	1415*905*1720	1415*905*1910
	in	45.5*35.6*67.7	55.7*35.6*67.7	55.7*35.6*75.2
Supporter	680	680	680	680
Containerload(20/40/40H)	10/20/20	8/16/16	8/16/16	8/16/16
Alarm	Sound and Flash	Sound and Flash	Sound and Flash	Sound and Flash
Certificate	NMPA CFDA	/	NMPA CFDA CE,EN12469	NMPA CFDA CE,EN12469

Product appearance and specifications are subject to change without notice

Main Uses

Featuring many patented technologies and certified to ISO 146644.1 Class 5 standard, Haier Biomedical's clean bench laminar flow units are suitable for a wide range of clean air applications within various sectors including pharmaceutical, clinical, life science research, photoelectric or microelectronics manufacturing.

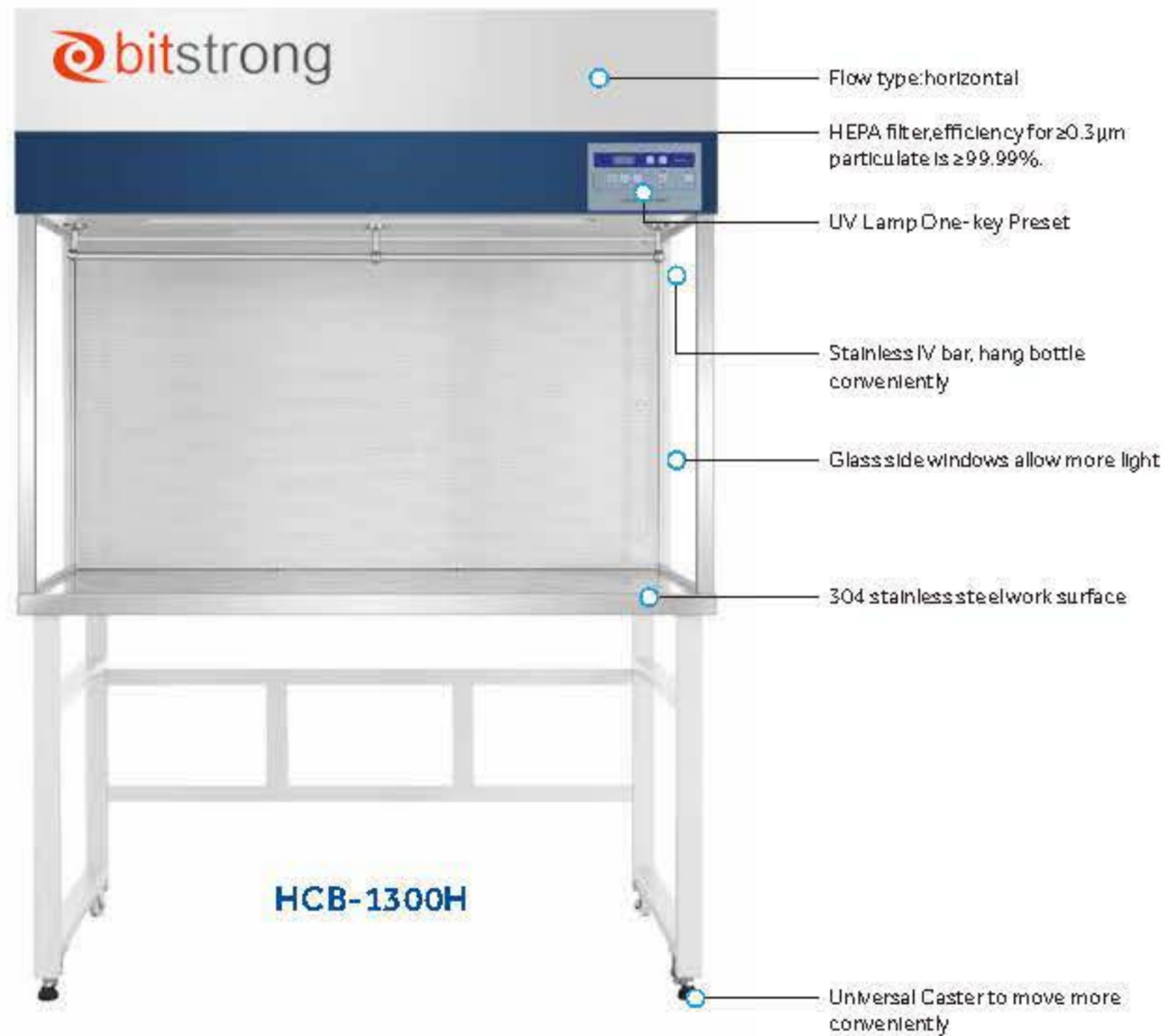

Clean Bench

Product Advantages

- Efficient damp-proof and fire-proof glass fibre HEPA filter, typical efficiency of $\geq 99.99\%$ for $\geq 0.3\mu\text{m}$ particulate.
- ISO 14644.1 Class 5 Standard, air cleanliness exceeds that required for Class 5 clean air applications.
- The industry's first innovated pre-cleaning function pre-cleans the working area before sample handling to further improve sample/product protection.
- UV lamp start-up delay time prevents operators from being exposed to potentially harmful ultraviolet light. The pre-set function for the ultraviolet sterilization improves user's operation efficiency.

Features

- Recessed internal lighting reduces eye fatigue.
- One-touch UV lamp operation, ultraviolet light can be set with one single key to automate on/off time and sterilisation time interval from 0 to 24 hours, reducing downtime. Audible and visual alarms remind users to leave, protecting them from UV injury.
- Inter-lock function provides a safer operation. The fluorescent light and ultraviolet light interlock with each other. The ultraviolet light can only be switched on when the fluorescent light is turned off. When the fluorescent light is on, the ultraviolet light is powered off immediately to minimize any risks.

Ergonomic Design

- The working surface is 800mm above the floor and suitable for an operator to stand or sit, allowing for flexible working through the day to reduce operator fatigue and make operations comfortable.
- The delay to start function of the ultraviolet sterilization prevents operators exposure to harmful lighting. When ultraviolet light is switched on, the sound and light alarms will notify operators to leave immediately. The light will come on after 10 seconds to prevent operators from being harmed by the ultraviolet light.
- The pre-set sterilization function improves productivity. The product has a ultraviolet sterilization pre-set timer function which provides more rest to users and improves work efficiency.
- The detachable chassis makes installation and moving convenient. It is equipped with universal casters and adjustable stand with levelling feet for convenient moving and cabinet placement.

- Featuring many patented technologies and authoritative testing certification for reliability
- Microcomputer intelligent control panel with durable touch buttons
- Multiple safety protection functions including UV delay start
- Interlocking function to put an end to incorrect operation
- Ergonomic design to ensure comfortable operation
- Memory function to avoid repeated start-up setting
- Integrated stand with universal casters



Clean Bench

High-Efficiency Filter HEPA

High-efficiency HEPA filter with efficiency of 99.99%@0.3µm, provides ISO14644.1 Class V standard clean air, safer and reliable clean air.

304 Stainless Work Surface

The durable and corrosion-resistant 304 stainless steel work table without fixing screws reduces the accumulation of dirt, reducing the risk of contamination.

Ergonomic Design

Recessed internal lighting reduces eye fatigue.

Patented Technology

- Patented UV sterilization start-up delay technology prevents injury by UV light. After the UV lamp switch is pressed down, the audible and visual alarm will be activated to remind the operator to leave in time;
- Pre-set function: This technology includes a pre-set UV sterilization start-up delay function to provide improved working efficiency.

Interlocking Function

There is an interlocking function between illuminating lamp and UV lamp, the UV lamp only works when the illuminating lamp is off. If the UV lamp is on, it can be turned off by pressing the daylight lamp, reducing the risk of incorrect operation.

Memory Function

The UV lamp start-up delay time, sterilization duration, pre-set start time, fan position can be set and saved by user on request for the convenient and quick cabinet start-up.

One-key Operation

- After the UV lamp switch is pressed, the time function can be activated automatically. The default sterilization time is 30min, which can be adjusted by user within 0-99min on request;
- Sterilization pre-set, when pressing the UV lamp, the pre-set lamp will light to remind user that the sterilization pre-set function has been activated and that the sterilization pre-set can be conducted.

Pre-cleaning Function

The pre-cleaning function can further improve the protection of samples.



Specifications

Model		HCB-900V	HCB-1300V	HCB-1300V	HCB-1300H	HCB-1300H	HCB-1600H
Flow Type		Vertical	Vertical	Vertical	Horizontal	Horizontal	Horizontal
Voltage/Frequency (V/Hz)		220/50	115/60	220/50	115/60	220/50/60	220/50/60
Power (W)		1200	1200	1200	350	350	350
Vibration Amplitude (UM)		2	2	2	2	2	2
Exhaust Filter Typical Efficiency		HEPA,99.99%@0.3um	HEPA,99.99%@0.3um	HEPA,99.99%@0.3um	HEPA,99.99%@0.3um	HEPA,99.99%@0.3um	HEPA,99.99%@0.3um
Average Velocity (M/S)		0.2-0.4	0.2-0.4	0.2-0.4	0.2-0.4	0.2-0.4	0.2-0.4
Fluorescent Lamp Intensity (Lux)		≥300	≥300	≥300	≥1000	≥1000	≥1000
Net/Gross Weight (approx)	kg	115/145	145/171	145/171	145/175	145/175	165/214
	lbs	254/319	320/376	320/376	319/385	319/385	363.7/471
Sound Level (dB(A))		58	58	58	61	61	61
Internal Dimension (W*D*H)	mm	900*530*520	1300*530*520	1300*530*520	1310*550*750	1310*550*750	1710*550*750
	in	35.4*20.9*20.5	51.2*20.9*20.5	51.2*20.9*20.5	51.6*21.7*29.6	51.6*21.7*29.6	67.3*21.7*29.6
External Dimension (W*D*H)	mm	970*630*1730	1370*630*1730	1370*630*1730	1380*792*1960	1380*792*1960	1780*790*1960
	in	38.2*24.8*68.1	53.9*24.8*68.1	53.9*24.8*68.1	54.4*31.2*77.2	54.4*31.2*77.2	70.1*31.1*77.2
Packing Dimensions (W*D*H)	mm	1105*745*1280	1505*745*1280	1505*745*1280	1465*940*1350	1465*940*1350	1865*940*1370
	in	43.5*29.3*50.4	59.3*29.3*50.4	59.3*29.3*50.4	57.7*37*53.2	57.7*37*53.2	73.4*37.0*53.9
Supporter		755mm high chassis	755mm high chassis	755mm high chassis	765mm high chassis	765mm high chassis	765mm high chassis
Cleanliness Classification		ISO 14644.1 Class 5	ISO 14644.1 Class 5	ISO 14644.1 Class 5	ISO 14644.1 Class 5	ISO 14644.1 Class 5	ISO 14644.1 Class 5
Container Load (20'40'40'H)		15/33/33	10/25/25	10/25/25	8/16/16	8/16/16	6/12/12
Certification		CE,NMPA(CFDA)	/	CE,NMPA(CFDA)	/	CE	CE,NMPA(CFDA)

Product appearance and specifications are subject to change without notice



**CO₂
Incubator**

Concise Test Results with Accurate Temperature Control

Precise temperature control within the fluctuation range of $\pm 0.1^{\circ}\text{C}$, with six-sided heating based on fuzzy PID control principles ensures the normal growth of cells throughout their life cycle.



6-sided heating sketch

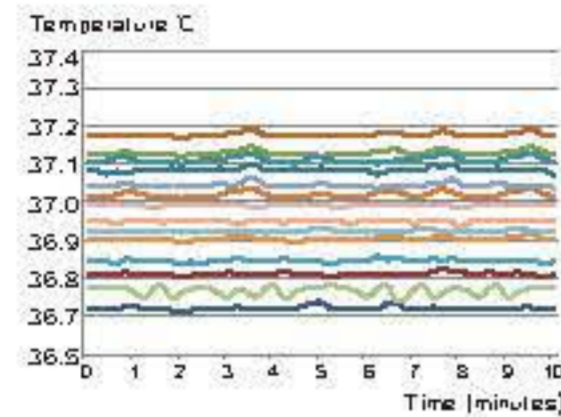

Uniformity of 27 measuring points $\leq \pm 0.3^{\circ}\text{C}$

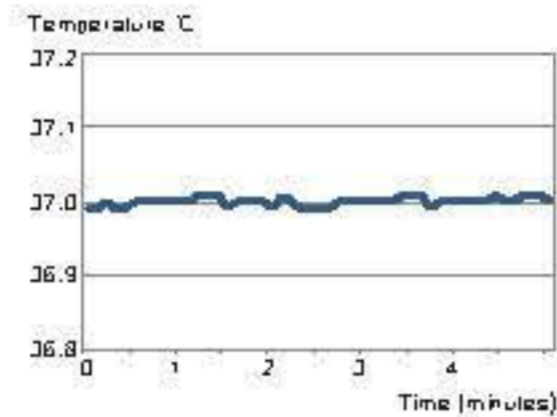

Central point volatility $\leq \pm 0.1^{\circ}\text{C}$

New IR Sensor Control Technology for Precise CO₂ Concentration

New type IR sensor technology, using NDIR measurement principles, can withstand high temperature up to 190°C . The silicon MEMS transmitter can withstand more than 300 dry heat sterilization cycles with a service life of 15 years. Built-in temperature and humidity compensation technology reduces the impact of changes of humidity and temperature without the need for calibration after high temperature sterilization. Five-point calibration yields a higher measuring accuracy and sensitivity with less drift.

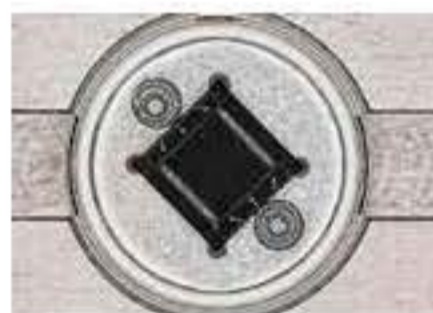

Silicon-based mems transmitter

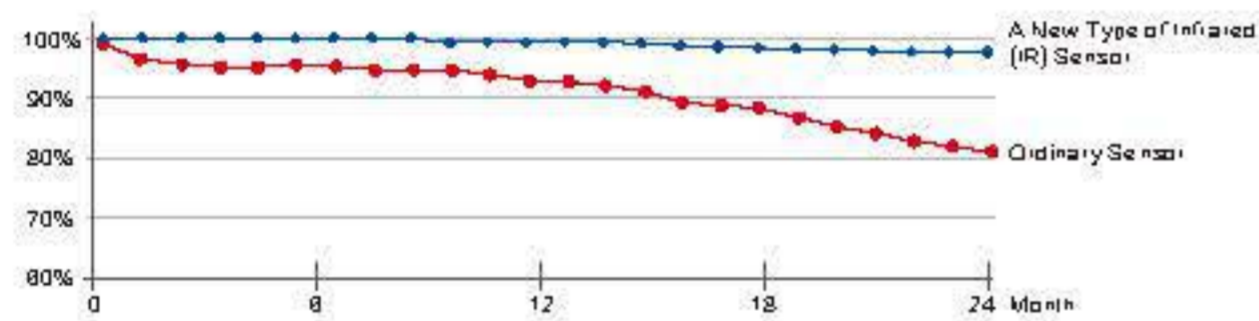

Sketch of drift less than 0.3%

Quick Environment Recovery System in the Incubator

Adopting active air flow control technology, based on the fuzzy PID control principle, the parameters can be restored without overshoot. For example, with the door open for 30 seconds, the temperature and CO₂ concentration is quickly restored within 4 minutes. Even if multiple users share a CO₂ incubator and frequently open and close the door, the stability and uniformity of the incubator can be ensured.

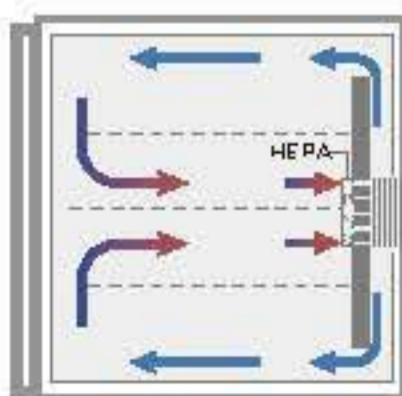
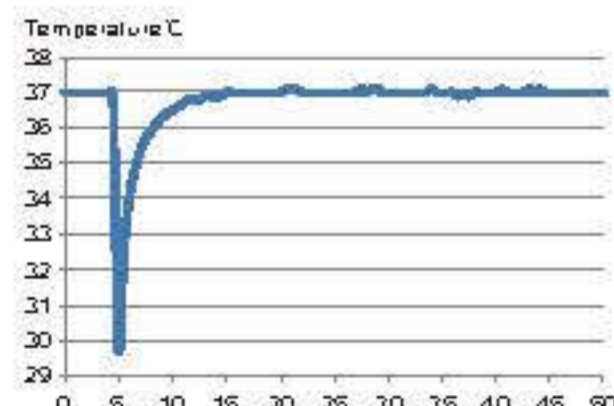
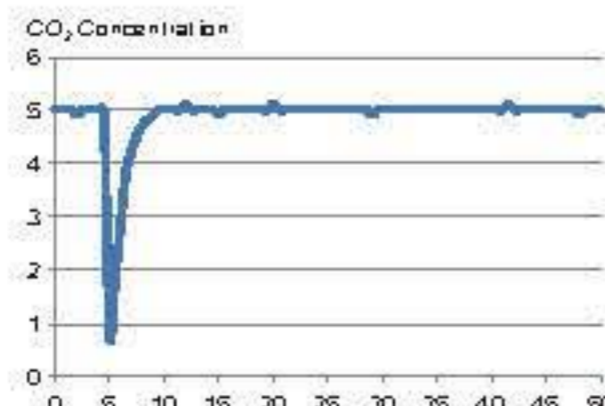

Illustration of purified airflow



Temperature recovery curve (door open for 30s)



CO₂ concentration recovery curve (door open for 30s)

CO₂ Incubator

180°C Dry-Heat Sterilization Technology

Effective sterilization of biological contaminants including microorganisms and fungal spores with strong resistance. Easy one-step 180°C High temperature, dry-heat sterilization (without the need for consumables), simply press the "sterilization key" to activate 12 hours sterilization process. The sterility level of all surfaces in the working chamber meets WS/T367-2012 requirements. During the sterilization process, all the internal components (including CO₂) sensors are not disassembled with no need for separate sterilization to effectively avoid secondary contamination.

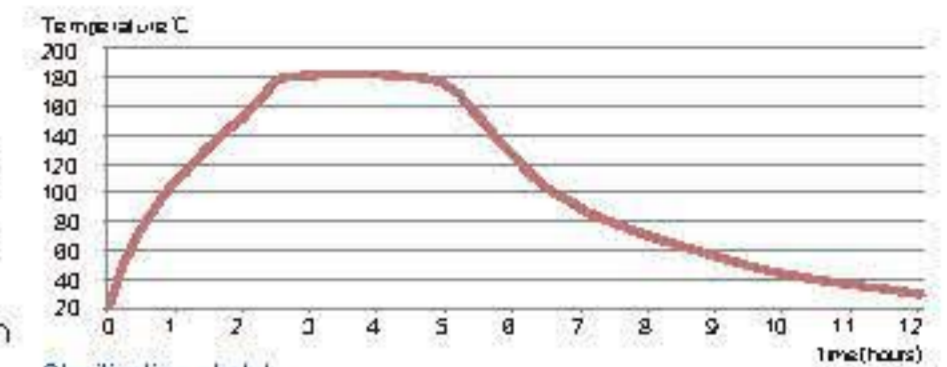

Sterilization sketch

Fifty-seven points were tested in the working chamber, including glass inner doors and partitions. All regions reached 180°C and maintained for 2 hours.

Comparison of Cell Environment Disinfection vs Dry-Heat Sterilization



Ultraviolet disinfection of ordinary CO₂ incubator
Cells exposed to bacterial environment



90°C hydrothermal disinfection of ordinary CO₂ incubator
Cells exposed to bacterial environment



180°C dry-heat sterilization of higher CO₂ incubator
Pollution-free cell growth environment

High Efficiency Bacteria Filtration with High Efficiency Microbial Filter



The CO₂ inlet is equipped with a high-efficiency microbial filter, with a filtration efficiency of 99.99% for particles larger than or equal to 0.2 micron in diameter. It can effectively filter bacteria and dust particles in CO₂ gas inline to ensure the safety of experimental results.

Easy to Clean Interior

The working chamber is manufactured with stainless steel, utilizing a laser seamless welding and a plasma electropolishing process, to create large arc angled corners which with the bracket-less design, means the unit is easy to clean.

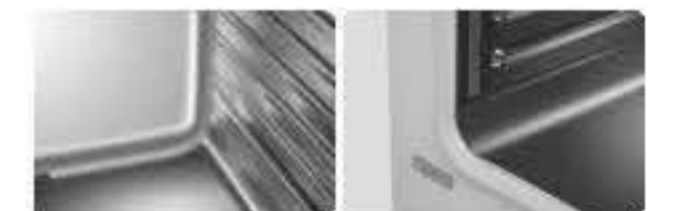

Intelligent Interactive and Easy Touch Operation

Touchscreen controller, sensitive to touch, even when you are wearing rubber gloves. Normal operation parameters are displayed in green, while abnormal operation parameters are in red, with data shown at a glance. When the liquid level is low, a buzzing alarm will also be activated alongside the visual red warning display.



Home screen red warning example

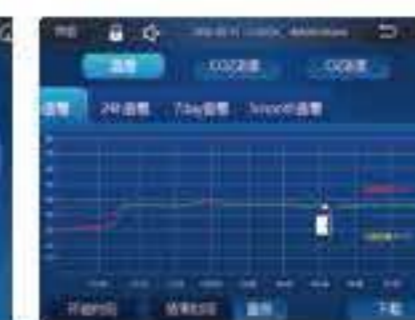

Real-time display of operation data real-time display of temperature, CO₂ concentration and CO₂ concentration, and the data during the culture cycle can be viewed at any time



An no uncorrected notification designed for multiple users of the same incubator, makes important information clear to all users



Operation mode with clear management authority: three-levels of authority to ensure the security of data

Monitor the Incubator in Realtime

The configuration of IoT module with multi-screen interaction provides real-time data on the set parameters, actual operation parameters, operation curves, records, and event records through the IoT cloud platform. The operation of incubator can be monitored at anytime and anywhere through mobile App or any web enabled device. The alarm function and service function are available through simple one touch button.



Anti-condensation Heating System Reduced Contamination Risk

The door on the CO₂ incubator can radiate heat to the inner glass door, effectively preventing the glass door from forming condensation. This eliminates the possibility of microbial contamination caused by any condensation.

Intelligent Control of Circulating Air to Maintain Uniformity

The air flow for circulation can be adjusted automatically. The air flow is optimized to avoid evaporation of test samples and to ensure proper uniformity throughout the chamber.

Comprehensive Alarm System

The incubator ensures the safety of experiments and processes by an independent temperature alarm system including a sound, light and remote reminder. Other alarms include CO₂ concentration, door ajar, and water level.

Thoughtful Design with Attention to Details



Anti-slip and anti-slide design of integral partition



Convenient drainage design, clean and convenient.

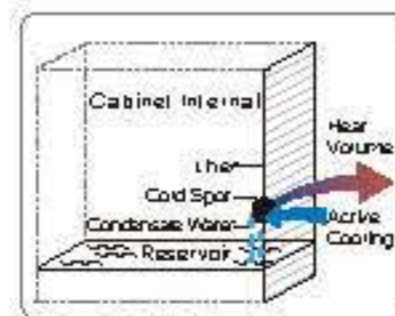

Active heat pipe condensation technology with condensate water directly return to reservoir



Data accessible for 15 years with large storage capacity, and data exportable through USB

CO₂ Incubator

Specifications

Model		HCP-80	HCP-168	HCP-258	
Type		Air Jacket	Air Jacket	Air Jacket	
Construction	Chamber Volume [L]	80	170	258	
	Interior Chamber	Stainless Steel			
	Exterior Chamber	Cold-rolled Steel Powder Coated			
	Access Port	35mm Diameter			
Data Outputs	Remote Alarm Contacts, USB, and Optional 4-20mA				
Dimensions	Net/Gross Weight [approx]	kg	75/100	110/140	
		lbs	165/220	242.5/308.6	297/374
	Interior Dimensions [W*D*H]	mm	400*420*490	490*560*650	570*610*745
		in	15.7*16.5*19.3	19.3*22*25.6	22.4*24.0*29.3
	Exterior Dimensions [W*D*H]	mm	625*684*735	714*812*887	794*867*985
		in	24.6*26.9*28.5	28.1*32*34.9	31.3*34.1*38.8
Packing Dimensions [W*D*H]	mm	695*755*915	760*840*1050	865*940*1135	
	in	27.3*29.7*36.0	29.9*33.1*41.3	34.0*37.0*44.7	
Shelves	Dimensions [W*D]	mm	380*300	470*434	550*484
	Number Standard/Maximum		3/7	3/11	3/13
	Max.load Per Shelf/Total Load	kg	10/30	10/30	10/30
	Construction		Perforated, Adjustable		
Electrical	Rated Voltage Power Supply [V/Hz]		220/50	220/50	220/50
	Nominal Consumption [kw] [Steri-run]		0.07 [0.9]	0.095 [1.4]	0.12 [1.6]
Control	Controller		Microprocessor	Microprocessor	Microprocessor
	Display		7" LCD Screen	7" LCD Screen	7" LCD Screen
CO ₂	Control		±0.1%	±0.1%	±0.1%
	Range		0-20%	0-20%	0-20%
	Alarm Range		±0.5%	±0.5%	±0.5%
	Inlet Pressure		12-17Psi [0.8-1.2 Bar]		
	Gas Purity	%	Min.99.5 or Medical Quality		
	Sensor		IR	IR	IR
	Recovery Time at 5vol.-%/CO ₂ for a 30 Second Door Opening *		4min	4min	4min
Alarms	CO ₂ Inlet Filter		<0.2µm	<0.2µm	<0.2µm
	High/Low Temperature		Y	Y	Y
	Remote Alarm		Y	Y	Y
	Excessive CO ₂ Concentration		Y	Y	Y
	Water Shortage		Y	Y	Y
Temperature Parameter	Door Ajar		Y	Y	Y
	Control		±0.1°C	±0.1°C	±0.1°C
	Range		Range 3°C Above Ambient to 55°C		
	Uniformity		±0.3°C	±0.3°C	±0.3°C
	Ambient Range		18-32°C	18-32°C	18-32°C
	Sensor		Pt1000	Pt1000	Pt1000
Sterilization Cycle	Recovery Time at 37°C for a 30 Second Door Opening *		4min	4min	4min
	Cycle Temperature		180°C on all Internal Surfaces		
Humidity	Cycle Duration		Under 12 Hours	Under 12 Hours	Under 12 Hours
	RH [Relative Humidity]		Setting 37°C ≥90%	Setting 37°C ≥90%	Setting 37°C ≥90%
	Humidity Reservoir		Max.1.3L/Min 0.5L	Max.3L/Min 0.5L	Max.3.6L/Min 0.5L
Optional	Hepa Filter		Y	Y	Y
	Regulator		Y	Y	Y
	RS485		Y	Y	Y
	4-20mA		Y	Y	Y
Certification	The Cylinder Switch		Y	Y	Y
			CE	CE	CE

Product appearance and specifications are subject to change without notice

Running Mode: automatic mode
Liquid Level: 100mm
Point A Temperature: -190°C
Point B Temperature: -196°C
Inlet Valve: Open

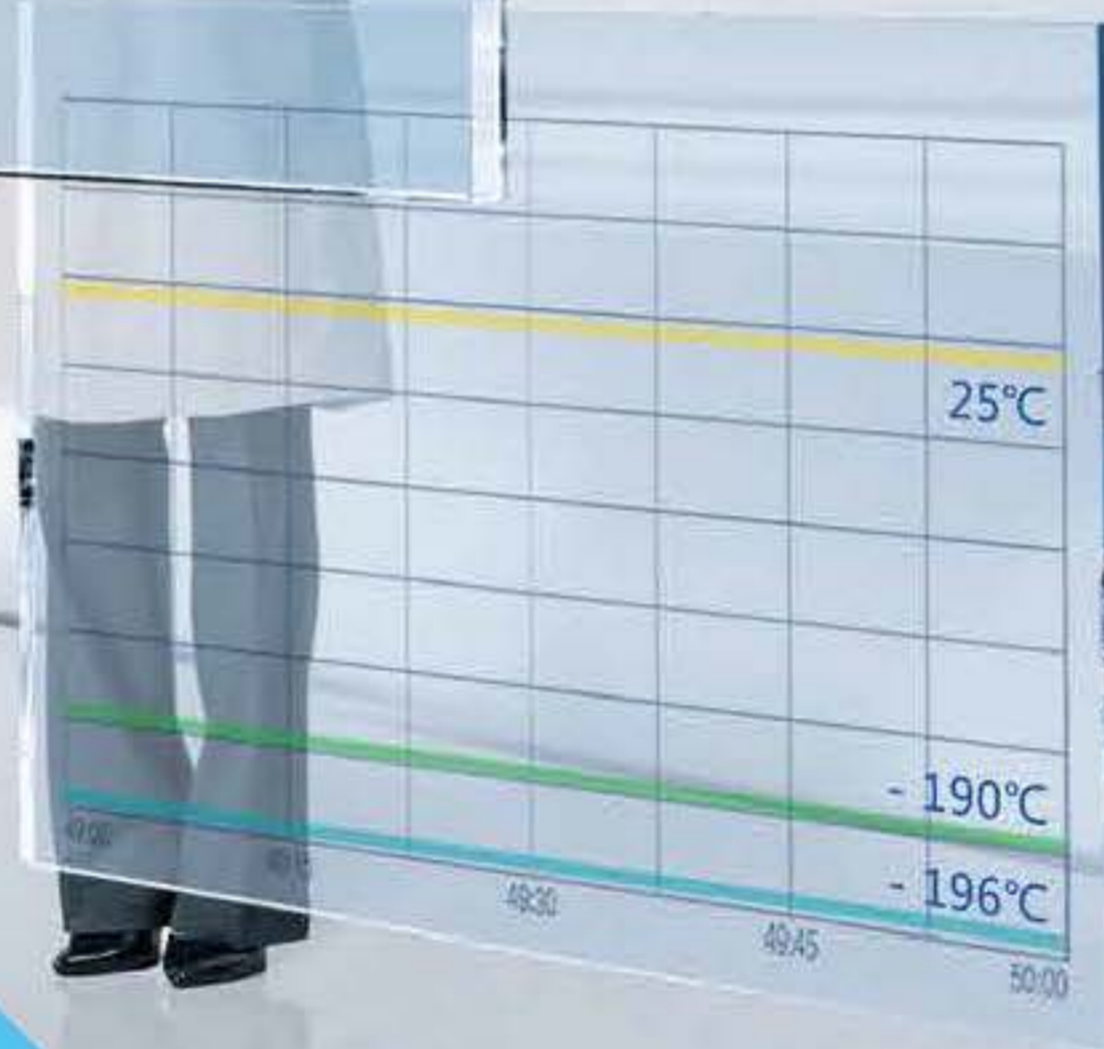

Liquid Nitrogen Storage Solutions

Biobank Series for Large Scale Storage

Biobank series for large scale storage is designed to ensure the maximum storage capacity with the minimum consumption of liquid nitrogen to lower the overall cost of operation.

Key Features

- Massive capacity between 13,000 to 94,875×2ml Vials
- Vapour phase storage is the only guaranteed method to prevent cross-contamination
- Vapour phase storage at -190°C
- 5-Year vacuum warranty
- One-touch defogging for easier access
- LN₂ splash proof ensures a safer operation
- Can be used to store all kinds of biological sample

Product Advantages

Optimal Use of Storage Space

Racks are stored on the rotating tray with an appropriate distance from the wall of the chamber. Liquid nitrogen or supercooled nitrogen vapour is filled in the space between the tray and the wall to maintain temperature uniformity. Storage space is equally divided into four or six fan-shaped storage areas which are clearly labelled. Each storage room is easily rotated to the opening of the tank for convenient sample access.



Designed for Both Liquid and Vapour Phase Storages

Each model of Biobank series for large scale storage is designed for both liquid and vapour phase storage. For vapour phase storage, samples are located away from the liquid nitrogen at a uniform temperature close to that of liquid nitrogen.

Advanced Vacuum Technology and Superinsulation Technology

Haier Liquid Nitrogen Storage System Biobank series for large scale storage applies advanced vacuum technology and superinsulation technology to ensure storage safety and temperature uniformity while reducing the consumption of liquid nitrogen. The temperature difference of the entire storage area does not exceed 10°C even in vapour phase storage. Temperature near the top of the shelf is as low as -190°C.

Cryosmart Intelligent Liquid Nitrogen Control System

Haier Liquid Nitrogen Storage System Biobank series for large scale storage feature the Cryosmart system for complete monitoring and controlling. High-precision temperature and liquid level sensors are used to ensure accuracy. All data and samples are protected by a secure access control system.



Biomedical Liquid Nitrogen Storage System

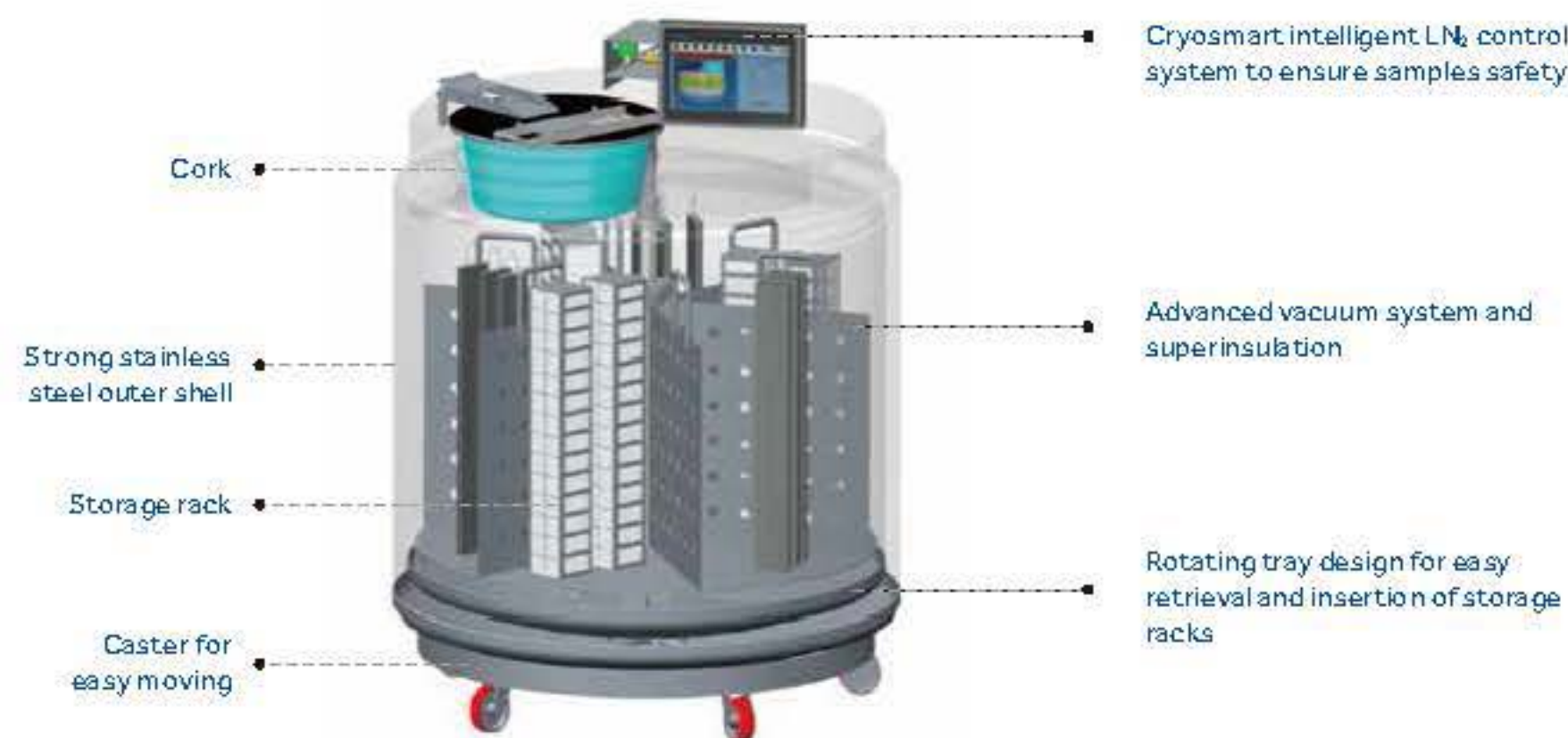

Liquid and Gas Phase

Liquid Phase

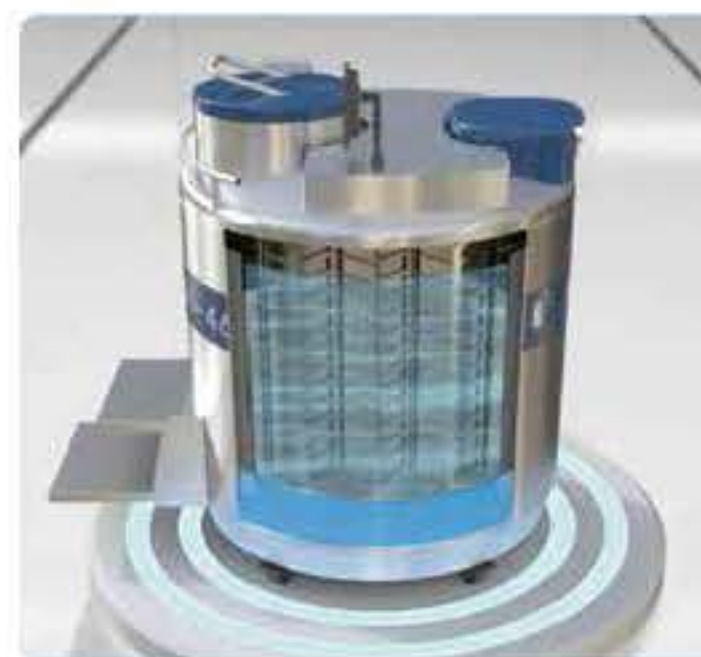

Top of the Container



Gas Phase

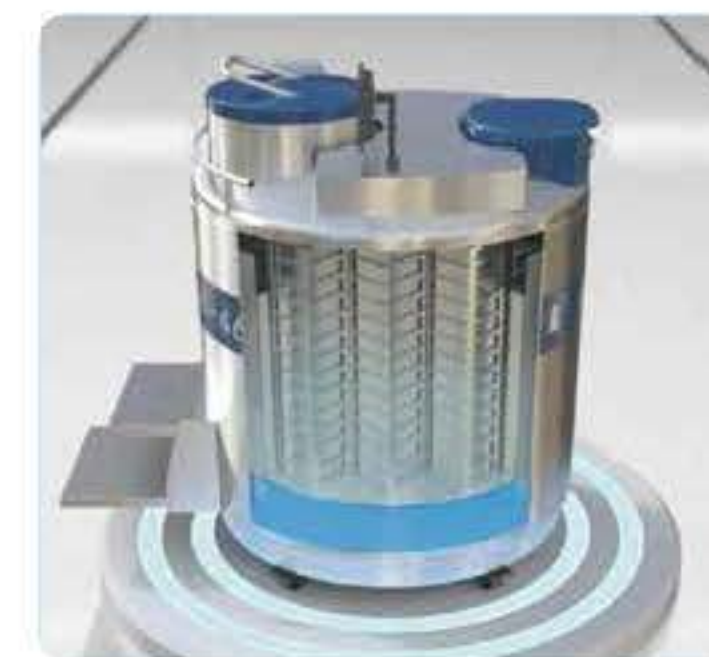

Liquid Feed System



Vapour condensation near the container opening is controlled. Reducing the amount of water vapour solidification on the outer surface of the neck. This unique design of the opening strengthens the structure of the tank under a full load, helping to extend its service life.



Small self-pressurized liquid nitrogen supply vessels are available and suitable for smaller biobank models.



Temperature Test Graph



- ① Precooling stage when freezer filled to high level
- ② Lid open test, -179.2°C max
- ③ Temperature maintained below -135°C for 22 days

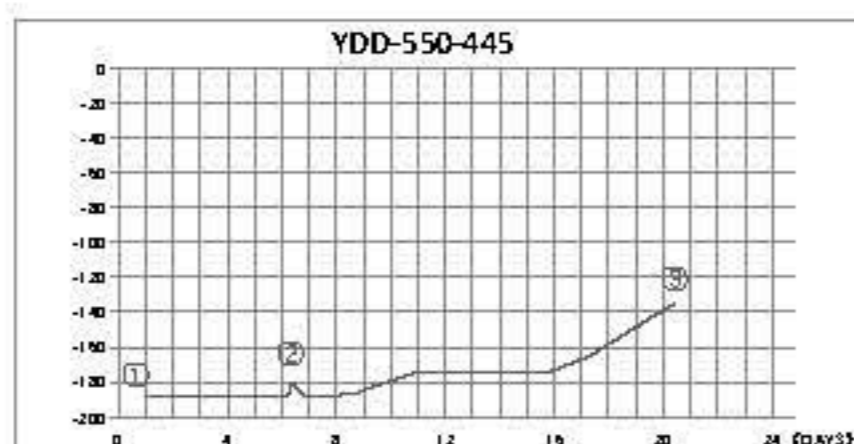

- ① Precooling stage when freezer filled to high level
- ② Lid open test, -180.2°C max
- ③ Temperature maintained below -135°C for 20 days

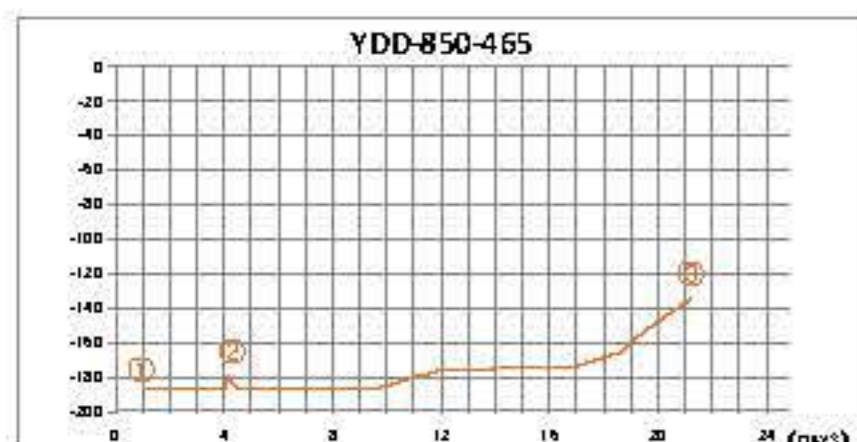

- ① Precooling stage when freezer filled to high level
- ② Lid open test, -179.4°C max
- ③ Temperature maintained below -135°C for 21 days

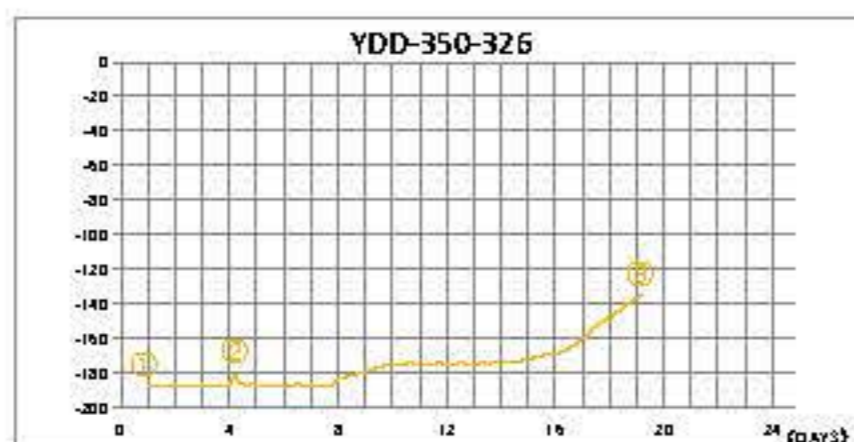

- ① Precooling stage when freezer filled to high level
- ② Lid open test, -181.4°C max
- ③ Temperature maintained below -135°C for 19 days

Temp Test indicates typical performance of Haier Biobank freezer with factory recommended level settings. Actual performance may vary with atmospheric conditions and usage.

Biomedical Liquid Nitrogen Storage System



Technical Parameters

Model	YDD-350-326	YDD-370-326	YDD-550-445	YDD-750-445	YDD-850-465
2ml Volume	13K	16K	27K	38K	43K
Maximum Storage Capacity					
2 ml Vials (Internal Thread)	13000	15600	27000	37800	42900
Freeze Rack (100 wells)	12	12	24	24	32
Freeze Rack (25 wells)	4	4	12	12	4
Layers of each Rack	10	12	10	14	13
5 ml Vials (Internal Thread)	5360	6232	11220	17952	18844
Freeze Rack (81 wells)	12	12	24	24	32
Freeze Rack (25 wells)	4	4	12	12	4
Layers of each Rack	5	6	5	8	7
Performance					
Volume of LN ₂ (L)	350	370	587	783	890
Volume of LN ₂ under the Tray (L)	55	55	80	80	135
Dimensions					
Inside Neck Diameter (mm)	326	326	445	445	465
Height (mm)	1263	1423	1266	1499	1496
Operating Height (mm)	1263	1096	970	1216	980
Outside Diameter (mm)	875	875	1104	1104	1190
Door Width Requirement (mm)	895	895	1124	1124	1210
Empty Weight (kg)	219	230	328	372	441
Gross Weight (kg)	502	529	802	1005	1160
Shipping Weight (kg)	358	438	520	616	702

Blood Bag Capacity

Model	YDD-350-326			YDD-370-326			YDD-550-445			YDD-750-445			YDD-850-465		
Bag Specifications	Total No. of Bags	Rack Layers	No. of Racks	Total No. of Bags	Rack Layers	No. of Racks	Total No. of Bags	Rack Layers	No. of Racks	Total No. of Bags	Rack Layers	No. of Racks	Total No. of Bags	Rack Layers	No. of Racks
25 ml 791 OS/U	1296	6	216	1512	7	216	2376	6	396	5168	8	396	3360	7	480
50 ml 4R9951	792	6	132	924	7	132	1416	6	236	1888	8	236	2072	7	296
500 ml DF-200	168	3	56	—	—	56	336	3	112	580	5	112	544	4	136
250 ml 4R9953	300	3	100	—	—	100	552	3	184	920	5	184	944	4	236
500 ml 4R9955	192	3	64	—	—	64	408	3	136	680	5	136	640	4	160
700 ml DF-700	96	3	32	—	—	32	204	3	68	272	4	68	320	4	80



Technical Parameters

Model	YDD-1000-465	YDD-1300-635	YDD-1600-635	YDD-1800-635
2 ml Volume	51K	59K	76K	95K
Maximum Storage Capacity				
2 ml Vials (Internal Thread)	51000	58500	76050	94875
Freeze Rack (100 wells)	30	54	54	60
Freeze Rack (25 wells)	16	18	18	13
Layers of each Rack	15	10	13	15
5 ml Vials (Internal Thread)	22640	28944	33768	46665
Freeze Rack (81 wells)	30	54	54	60
Freeze Rack (25 wells)	16	18	18	13
Layers of each Rack	8	6	7	9
Performance				
Volume of LN ₂ (L)	1014	1340	1660	1880
Volume of LN ₂ under the Tray (L)	135	265	300	320
Dimensions				
Inside Neck Diameter (mm)	465	635	635	635
Height (mm)	1517	1342	1534	1662
Operating Height (mm)	950	997	967	1097
Outside Diameter (mm)	1190	1565	1565	1565
Door Width Requirement (mm)	1210	1585	1585	1585
Empty Weight (kg)	495	851	914	985
Gross Weight (kg)	1314	1934	2255	2504
Shipping Weight (kg)	926	1168	1426	1520

Blood Bag Capacity

Model	YDD-1000-465			YDD-1300-635			YDD-1600-635			YDD-1800-635		
Bag Specifications	Total No. of Bags	Rack Layers	No. of Racks	Total No. of Bags	Rack Layers	No. of Racks	Total No. of Bags	Rack Layers	No. of Racks	Total No. of Bags	Rack Layers	No. of Racks
25 ml 791 OS/U	4356	9	484	4716	6	786	5502	7	786	7758	9	862
50 ml 4R9951	2682	9	298	2916	6	486	3402	7	486	4905	9	545
500 ml DF - 200	1180	5	236	666	3	222	888	4	222	1290	5	258
250 ml 4R9953	670	5	134	1170	3	390	1560	4	390	2095	5	419
500 ml 4R9955	810	5	162	828	3	276	1104	4	276	1520	5	304
700 ml DF - 700	400	5	80	396	3	132	528	4	132	775	5	155

Square Canister & Racks Layout

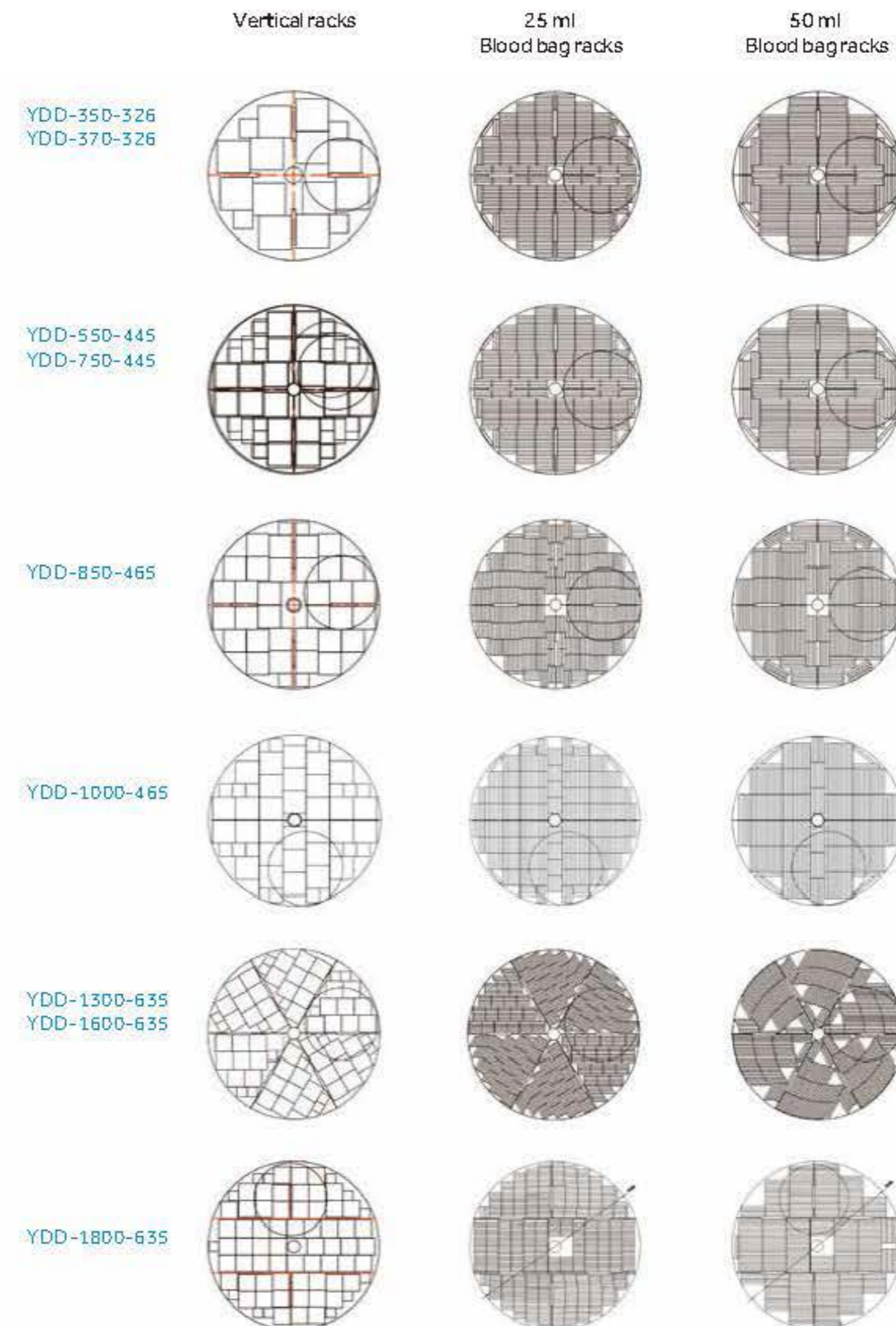

Smart Series (Square Racks)

The smart, IoT and cloud management system monitors temperature and liquid levels simultaneously to provide accurate and real-time information on the critical parameters to ensure ultimate sample safety.

Key Features

- 5 models from 2,400 to 6,000 cryovial capacity
- 5 years vacuum warranty
- Durable aluminium construction
- Real time monitor of temperature and fluid level
- Cloud data storage for traceability
- Low consumption rate and high performance stability
- New lock design

Product Advantages

Colour identification for pickup tool handle

Pickup tool handles are colour-coded for ease of separating storage zones and managing samples.



New lock design

Special and dedicated lock design assures sample safety.



Dual monitoring respectively for temperature and liquid level

Storage temperature and liquid level are automatically monitored by a high precision controller. Accurate and real-time information ensures samples safety.



Multilayer protection for ultimate safety

Temperature and fluid level are monitored in real time to safeguard the storage environment. Alarms can be transmitted through email, IM and wechat.

Cloud data storage for traceability

Temperature and fluid level data can be transmitted to Haier's IoT platform for storage. All data is traceable and stored permanently.

Low consumption rate and high performance stability

Automated manufacture ensures build quality and reliable vacuum which delivers stable and uniform temperature performance as well as low LN₂ consumption rates.



Biomedical Liquid Nitrogen Storage System

Accessories



Technical Parameters

Model	YDS-65-216-FZ	YDS-95-216-FZ	YDS-115-216-FZ	YDS-145-216-FZ	YDS-175-216-FZ
Maximum Storage Volume					
No. of Rack	6	6	6	6	6
2ml Storage Vials (100/box)	2400	3000	3600	4800	6000
Layers in Rack	4	5	6	8	10
5ml Storage Vials (81/box)	—	972	1458	1944	2430
Layers in Rack	—	2	3	4	5
Function					
Liquid Nitrogen Volume (L)	65	95	115	145	175
Static Evaporation Rate* (%/d)	0.78	0.97	0.94	0.96	0.95
Static Holding Time** (Day)	83	98	122	151	184
Dimensions					
Neck Opening (mm)	216	216	216	216	216
Overall Height (mm)	712	774	846	946	1060
Overall Diameter (mm)	681	681	681	681	681
Empty Container Weight (kg)	39.3	42.5	43.7	49.9	54.8
Full Container Weight (kg)	81.5	112.3	133.5	158.9	199.5
Shipping Weight (kg)	63.8	67.9	71.2	82.1	91.3

* Static evaporation and static holding time are theoretical values. Actual evaporation and holding time are affected by usage, atmospheric conditions and manufacturing tolerances.

** Static Holding Time: the amount of days it takes for all of the LN₂ to evaporate out after container is filled with liquid nitrogen to pre-cool and reach thermal equilibrium and the liquid nitrogen filling rate reaches 100% under standard atmospheric condition.

Medium Sized Storage Series (Square Racks)

Medium Sized Storage Series (Square Racks) features low LN₂ consumption and relatively small footprint for medium capacity sample storage.

Key Features

- Heavy duty lockable enclosure offers excellent security
- Compatible with all major cryobox brands
- Liquid or vapour phase option available
- Durable aluminium construction
- Temperature monitoring available
- High thermal efficiency
- 5 year vacuum warranty
- Ultra-low evaporation loss



Product Advantages

ULT Storage with Extremely Low LN₂ Evaporation Loss

Freezer racks are in the ultra-low temperature environment with extremely low LN₂ evaporation. Even stored in vapour phase, the temperature will be below -190°C for a long time.

Advanced Vacuum Technology and Superinsulation Technology

Advanced vacuum and insulation technologies ensure cryopreservation for up to four months.

Compatible for Blood Bag Storage

Suitable for blood bag applications, the racks can be adapted to provide temporary blood bag storage before transferring bags to larger LN₂ storage tanks.



Temperature Monitor

Temperature monitor can track temperature inside the tank continuously and reliably. It is the ideal choice for monitoring samples storage temperature of long-term cryopreservation and alerting users to refill tank.

Temperature monitor ZTC-100A offers real-time temperature display and audible/visual alarms for high temperature and sensor failure.



Biomedical Liquid Nitrogen Storage System

Technical Parameters

Model	YDS-65-216-F	YDS-95-216-F	YDS-115-216-F	YDS-140-216-F	YDS-175-216-F
Maximum Storage Capacity					
No. of Rack	6	6	6	6	6
No. 2.0 ml Cryovials (100 / Box)	2400	3000	3600	4800	6000
No. of Boxes in (2ml each Rack)	4	5	6	8	10
No. 5.0 ml Cryovials (81 / Box)	-	972	1458	1944	2430
No. of Boxes in (5ml each Rack)	-	2	3	4	5
Performance					
Volume of LN ₂ (L)	65	95	115	140	175
Static Evaporation Rate* (L/Day)	0.78	0.97	0.94	0.96	0.95
Static Holding Time** (Day)	83	98	122	151	184
Dimensions					
Neck Opening Diameter (mm)	216	216	216	216	216
Height (mm)	712	774	846	946	1060
Outer Diameter (mm)	681	681	681	681	681
Empty Weight (kg)	38.3	41.3	42.3	48.9	53.8
Gross Weight (kg)	80.8	112.4	132.8	157.3	198.5
Shipping Weight (kg)	61.8	65.9	72.9	80.1	89.2

* Static evaporation and static holding time are theoretical values. Actual evaporation and holding time are affected by usage, atmospheric conditions and manufacturing tolerances.

** Static Holding Time: the amount of days it takes for all of the LN₂ to evaporate out after container is filled with liquid nitrogen to pre-cool and reach thermal equilibrium and the liquid nitrogen filling rate reaches 100% under standard atmospheric condition.

Accessories

Caster Base	Cryogenic Box	216 Diameter Lock Cap	5 ml Customized Rack
5 ml Customized Cryogenic Box	Smart Cap	Square Rack	Smart Box (SW-300)

Dryshipper Series for Transportation (Round Canisters)

Dryshipper Series for Transportation (Round Canisters) is designed for safe sample transportation under cryogenic conditions (vapour phase storage, temperature under -190°C). Since the risk of LN_2 release is avoided, it is suitable for air transportation of samples.

- Rugged and Durable
- 3 Year Vacuum Warranty
- Cryo Absorbant
- Vapour Phase Storage
- Secure
- No LN_2 Spillage

Key Features

- Straw and cryovial storage options
- Rugged and durable aluminium construction
- Designed to ensure no LN_2 spillage
- Vapour phase cryogenic storage
- Faster LN_2 fill times
- Lockable lids
- 3 year vacuum warranty

Product Advantages

Liquid Nitrogen Absorption

Absorbent materials are used to absorb and retain LN_2 for safe transport. No spillover of LN_2 can occur even when the tank is capped.

Stainless Steel Mesh

Special stainless steel mesh divides storage space and LN_2 absorbents to prevent absorbent materials from contaminating the samples.

Complete Accessories Set

All models are offered a variety of stainless steel canisters and polycarbonate cryogenic boxes. Locking cover is optional.



Biomedical Liquid Nitrogen Storage System

Technical Parameters

Model	YDH-3	YDH-6-80	YDH-10-125	YDH-15-216	YDH-25-216
Maximum Storage Capacity					
No. of Canister	1	1	1	1	1
No. of Straws (0.5ml / EA)	132	374	854	—	—
No. of Straws (0.25ml / EA)	298	837	1940	—	—
No. of 2.0 ml Cryovials	—	—	100	300	500
No. of Boxes in (2ml per holder)	—	—	4	3	5
Performance					
Volume of LN_2 (L)	3	6	10	15	25
Absorbable Volume of LN_2 (L)	1.3	2.9	3.4	6	9
Static Evaporation* (L/Day)	0.16	0.2	0.45	1.5	0.89
Liquid Phase Static Holding Time**(Day)	20	37	23	10	29
Vapour Phase Static Holding Time*** (Day)	8	14	8	4	10
Dimensions					
Opening Diameter (mm)	93	80	125	216	216
Height (mm)	435	487	625	540	716
Outside Diameter (mm)	223	300	300	394	394
Canister Outside Diameter (mm)	38	63	97	—	—
Outside Height (mm)	120	120	120	—	—
Empty Weight (kg)	3.2	4.9	6.7	8.5	15
Gross Weight (kg)	4.7	7.5	11	25	30
Shipping Weight (kg)	5.5	7.7	9.7	15.2	20.5

* Static evaporation and static holding time are theoretical values. Actual evaporation and holding time are affected by usage, atmospheric conditions and manufacturing tolerances.

** Liquid Phase Static Holding Time: the amount of days it takes for all of the LN_2 to evaporate out after container is filled with liquid nitrogen to pre-cool and reach the final equilibrium and the liquid nitrogen filling rate reaches 100% under standard atmospheric condition.

*** Vapour Phase Static Holding Time: the amount of days it takes for all of the LN_2 to evaporate out after pouring liquid nitrogen into container to making absorbent materials fully absorb LN_2 under standard atmospheric condition.

Accessories



Smart Cap



Canister Pail+Square Rack



Smart Box | SW-3001

Self-pressurized Series for LN₂ Storage and Supply

Liquid Nitrogen Supplement Series for LN₂ Storage and Supply incorporates the latest innovation, its unique design utilises the pressure generated from the vapourisation of a small amount liquid nitrogen to discharge LN₂ into other containers. Storage capacities range from 5 to 500 litres.

- 5 Year Vacuum Warranty
- Liquid Storage
- Stainless Steel Construction
- Decant Valves
- Pressure Raising
- Integral Safety Mechanisms

Key Features

- All models are equipped with safety valves
- All welded stainless steel construction
- Rotary ring construction
- Labelled valves for easy identification
- 5 year vacuum warranty

Product Advantages

Stainless Steel Structure

Stainless steel structure can withstand the most demanding environment and ensure long-lasting security. It also provides reduced evaporation loss rate, compared with conventional welding insulation tanks.

Casters

All models have four casters for better mobility and convenient use in different occasions.

Variety of accessories

Each Self-pressurized Series for LN₂ Storage and Supply model is equipped with a pressure valve, a drain valve, a relief valve, and a pressure gauge.

Monolayer infusion hose



Float level meter



Additional Series for Liquid Nitrogen Tank (Comparison between Standard Series and K Series)



Biomedical Liquid Nitrogen Storage System

New Functions of K Series

▶ Digital meter for liquid level

DLZ-300
Digital display of fluid level
Remote data transmission
function



▶ Large diameter vent valve

Rapid relief of
over pressure
Protection of
safety valve



▶ Pressure stabilizing valve

Stabilize fluid pressure
during auto filling



Technical Parameters

Model	YDZ-5	YDZ-15	YDZ-30	YDZ-50	YDZ-100 YDZ-100K
-------	-------	--------	--------	--------	---------------------

Performance

Volume of LN ₂ (L)	5	15	30	50	100
Static Evaporation (L/Day)	0.15	0.38	0.75	1	1.3
LN ₂ Output (L/Min)	2	2	3	3	4

Dimensions

Height (mm)	510	750	879	991	1185
Outside Diameter (mm)	329	404	454	506	606
Empty Weight (kg)	15	23	32	54	75
Gross Weight (kg)	19.1	35.3	56.6	95.0	157.0
Shipping Weight (kg)	28	34	47	63	98

Pressure Parameters (MPa)

1. Standard working pressure 0.05, 2. Maximum working pressure 0.09, 3. First stage safety valve relief pressure 0.099, 4. Second stage safety valve release pressure 0.15, 5. Pressure gauge range 0-0.25

Model	YDZ-150	YDZ-200 YDZ-200K	YDZ-240K	YDZ-300 YDZ-300K	YDZ-500 YDZ-500K
-------	---------	---------------------	----------	---------------------	---------------------

Performance

LN ₂ Capacity (L)	150	200	240	300	500
Static Evaporation (L/Day)	1.95	2.4	2.9	3.3	5.5
LN ₂ Output (L/Min)	6	8	8	8	10

Dimensions

Height (mm)	1188	1265	1350	1459	1576
Outside Diameter (mm)	706	758	758	857	1008
Empty Weight (kg)	102	148	202	202	255
Gross Weight (kg)	225	380	448	448	665
Shipping Weight (kg)	132	164	177	232	324

Pressure Parameters (MPa)

1. Standard working pressure 0.05, 2. Maximum working pressure 0.09, 3. First stage safety valve relief pressure 0.099, 4. Second stage safety valve release pressure 0.15, 5. Pressure gauge range 0-0.25, 6. Rupture disc burst pressure 0.47

* Static evaporation and static holding time are theoretical values. Actual evaporation and holding time are affected by usage, atmospheric conditions and manufacturing tolerances.

**Vertical Automatic
High-pressure
Steam Sterilizer**



Scope of Application

This upright automatic rapid sterilization unit uses high temperature saturated steam as the sterilization medium. Applicable to testing laboratories, laboratories, operating rooms, supply rooms, higher education, animal husbandry, disease control centers and other medical and biomedical research units, achieves rapid sterilization of instruments, dressings, rubber, liquids, glassware, bacteria and cell culture medium, wastes, etc.

Product Features



Automatic Program Control

Water injection, heating, exhaust, sterilization, pressure relief, drainage, drying, automatic control of the whole process, no manual operation, one-click completion.



Automatic Drying Function (Auxiliary Drying)

The drying time can be set after the sterilization is completed.



Multiple Exhaust Methods

A variety of exhaust methods such as regular temperature setting exhaust, dynamic exhaust and full-process air escape, completely eliminates the cold air in the sterilizer and improves steam saturation, ensuring effective sterilization.



One-click Start of Stored Procedures

Equipped with quick programs for instruments, dressings, rubber and liquids, one-button start for easy operation.



Two Pressure Relief Methods

Two pressure relief methods are available: fast pressure relief and slow pressure relief. The slow pressure relief method for liquid sterilization can prevent liquid overflow caused by rapid buildup of pressure.



Warm-up Control and Timing Start

The preheating control function supports the sterilizer heating process, which shortens the heating time of the sterilizer and improves the efficiency of the process; equipped with timing start function and can start the sterilization program according to the predetermined time and arrange the process time accordingly.



HRLM-80

Safety Mechanisms

Automatic overpressure pressure relief:

When the set pressure is exceeded, the safety valve opens automatically to release the pressure.

Automatic over-temperature protection:

When the set temperature is exceeded, the system cuts off the power supply and alarms automatically generated.

Anti-drying protection:

When the water level is too low, the power will automatically cut off, the operation is stopped, and an alarm is automatically generated.

Door safety protection:

Real-time detection of door status, sterilization procedures cannot be started if the door is not tightly closed and there is a reminder to open the door; the sterilization can only start when the door is normally closed. However, when there is pressure in the sterilizer, the sealing door cannot be opened to prevent damage caused by steam leakage.

Sensor disconnection detection:

Monitors the status of the sensor in real time to ensure that the sensor is working properly to prevent excessive temperature caused by abnormal sensors.

Full protection thermal insulated door cover:

The door cover is made of high-performance thermal insulation material which completely covers the metal door, which prevents the operator from being burned.

Standard over-current, over-voltage protection and leakage protection.

Specifications

Model	Volume (L)	Weight (Kg)	Power Supply (V/Hz)	Power (W)	Exterior Dimension (W*D*H mm)	Interior Dimension (mm)	Maximum Pressure (Mpa)	Maximum Temperature (°C)	Rated Working Pressure (Mpa)	Pressure Display Range (Mpa)
HRLM-80	80	85	220/50	3200	546*750*1065	↓ 386*700	0.28	150	0.22	0-0.4
Sterilization Temperature Range	Temperature Control Precision (°C)	Dynamic Pulse Exhaust Times	Dynamic Pulse Exhaust Temperature	Solution Temperature (°C)	Holding Temperature (°C)	Sterilization Time Range	Cabinet and Door Material	Accessories		
105-136°C	0.1	0-9 (Settable)	110-136°C	40-100 (Settable)	40-100 (Settable)	0-999 mins	SUS304 Stainless Steel	2 Stainless Steel Sterilized Baskets	Optional Printer	



**Constant
Climate Chamber**

Scope of Application

Animal and plant tissue culture, drug stability test, cosmetic stability test, food shelf life test, electronic components aging test, packaging material stability test.

Product Advantages



Precise control:

- Accurate temperature and humidity control, long-term stability, 40 °C temperature uniformity ± 0.5 °C and central temperature fluctuation ± 0.2 °C, 75% humidity fluctuation $\pm 1\%$.

Power saving:

- Semiconductor technology, daily power consumption as low as 5 kWh, save up to 90% energy than compressor.

Water-saving:

- Intelligent control of PTC humidification, daily water consumption of 120-320ml, no waste water recycling, save space.

Silent:

- Semiconductor technology, low vibration, low noise, no pollution to the environment.

Product Features



Microprocessor control system:

- PID control principle, 10-inch touch screen, temperature control precision 0.1°C, humidity control precision 0.1%, temperature range 5-70 °C, humidity range 10%-90%.
- Display temperature, humidity and ambient temperature, you can query the history curve.
- Temperature alarm, humidity alarm, door alarm, sensor alarm, water shortage alarm can be connected to remote alarm interface.
- USB RS485 4-20mA LAN interface.



- High insulating performance polyurethane foam provides excellent insulation and stable cabinet temperatures reducing energy consumption



- Porthole is provided with a diameter of 35mm on the left side of the cabinet to facilitate independent testing of temperature and humidity.



- Optional electromagnetic lock, easy to be used by multiple people, independent management, safe to use.



- Expandable large capacity data storage, touch screen expandable 64GB memory, it can store 15 years of data and export it.



Constant Climate Chamber



- Multiple protection protocols - equipped with delay start, high/low temperature and light intensity protection in line with DIN12880 requirement for over/under temperature protection



- High precision temperature sensor, dual PT100 sensors for more accurate temperature control



- High precision capacitive humidity sensor



- Polyurethane foam insulation provides excellent thermal insulation, reducing energy consumption



International Quality Assurance

Accurate Temperature Control

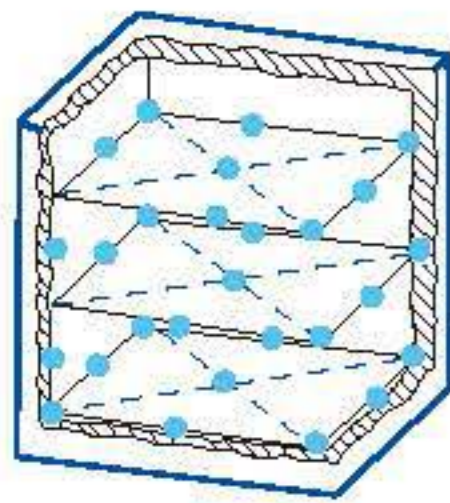

DIN12880 standard 27 test points

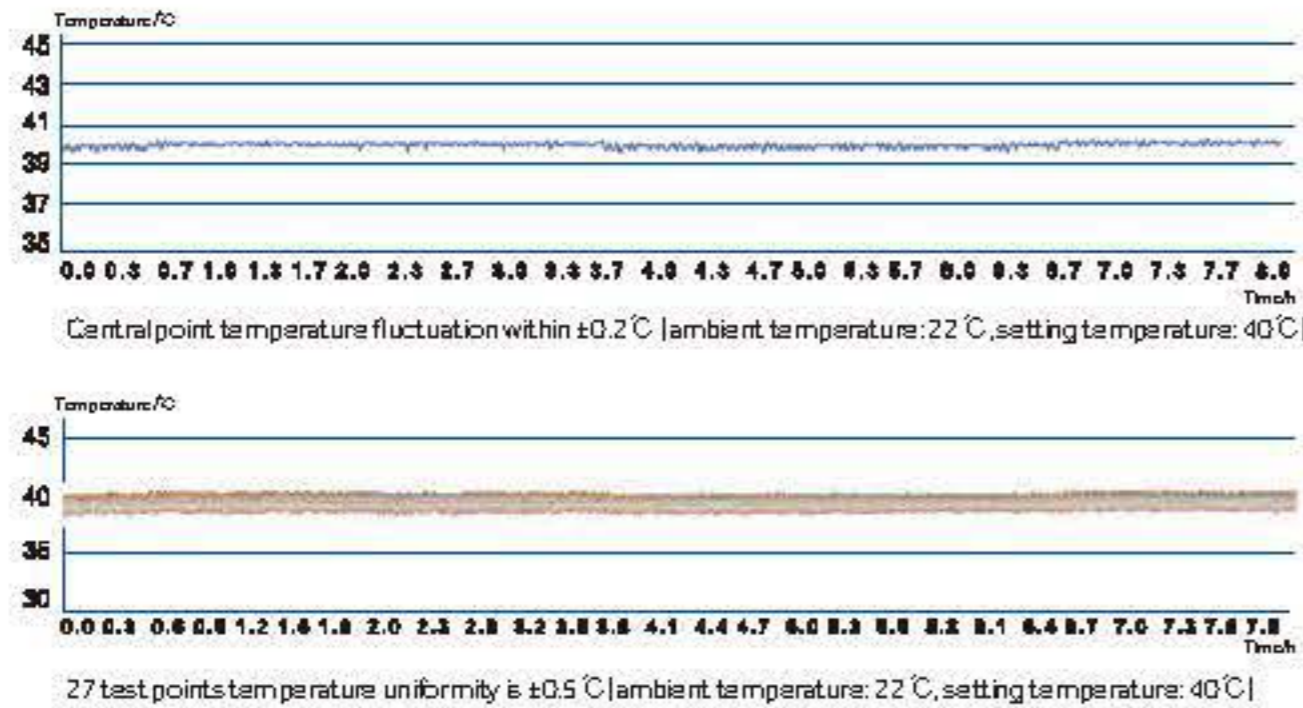

Accurate Humidity Control

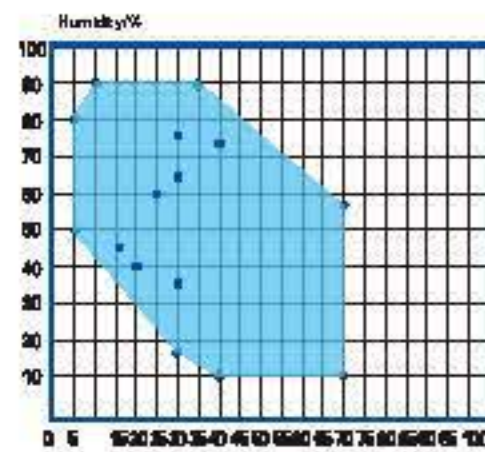

ICH standard test points

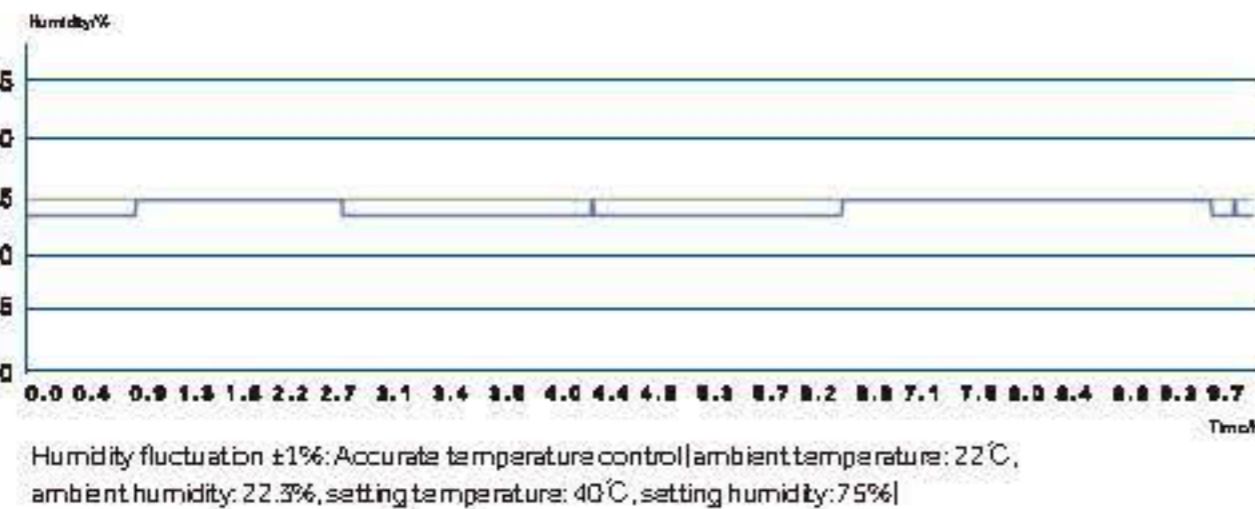

Constant Climate Chamber

Specifications

Model		HHS-256	HHS-506	HHS-756	
Construction	Chamber Volume (L)	256	506	756	
	Interior Chamber	Stainless Steel	Stainless Steel	Stainless Steel	
	Exterior Chamber	Galvanized Sheet Powder Coating			
	Access Port	35mm Diameter	35mm Diameter	35mm Diameter	
Dimensions	Net/Gross Weight	kg	145/188	215/260	280/328
	Interior Dimensions (W*D*H)	mm	650*570*700	740*570*1200	1100*570*1200
		in	25.6*22.5*27.6	29.1*22.4*47.2	43.3*22.4*47.2
	Exterior Dimensions (W*D*H)	mm	833*900*1185	923*900*1685	1283*937*1632
		in	32.8*35.4*46.7	36.3*35.4*66.3	50.5*36.9*64.3
	Packing Dimensions (W*D*H)	mm	1030*960*1270	1110*965*1780	1360*1035*1785
	in	40.6*37.8*50	43.7*38*70.1	53.5*35.6*70.3	
Shelves	Dimension / mm (W*D)	597*531	687*531	1048*531	
	Standard Qty / Max Qty	2/5	2/10	2/10	
	Max Weight Per Shelf	Kg	20	20	20
	Structure	Slide Rail, Adjustable	Slide Rail, Adjustable	Slide Rail, Adjustable	
Electrical	Voltage / Frequency (V/Hz)	220/50	220/50	220/50	
	Power (W)	600	1100	1700	
	Day Consumption at 25°C & 40% RH (kwh)	4.6	5.4	5.6	
Control	Controller	Microprocessor	Microprocessor	Microprocessor	
	Display	10" Smart LCD Screen	10" Smart LCD Screen	10" Smart LCD Screen	
	The Set Range (°C)	5~70	5~70	5~70	
The Temperature Parameter	Control Precision (°C)	± 0.1	± 0.1	± 0.1	
	Temperature Uniformity at 25°C & 40% RH (°C)	± 0.2	± 0.2	± 0.1	
	Temperature Fluctuation at 25°C & 40% RH (°C)	± 0.1	± 0.1	± 0.1	
	The Sensor	Pt1000	Pt1000	Pt1000	
	Rate of Temperature Rise (°C / min)	1	0.8	0.6	
	30 Seconds Recovery Time After Door Opening at 40°C (min)	3	3.8	5	
	Humidity Parameter	Humidity Setting Range (% RH)	10~90	10~90	10~90
Humidity Setting Accuracy (% RH)		0.1	0.1	0.1	
Humidity Fluctuation at 25°C & 40% RH (%RH)		± 0.5	± 0.5	± 0.5	
Daily Water Consumption (ml)		120	240	320	
Noise	Noise (dB(A))	52	55	57	
	Electromagnetic Lock	Y	Y	Y	
Optional	Punching Board	Y	Y	Y	
	Remote Alarm Interface	Y	Y	Y	
	4-20mA Interface	Y	Y	Y	
	Rs485	Y	Y	Y	
	Network Interface	Y	Y	Y	
	Power Failure Alarm Interface	Y	Y	Y	
Standard	Water Level Alarm	Y	Y	Y	
Others	Others	CE	CE	CE	

Product appearance and specifications are subject to change without notice

Health
Care Product



Bacterial and viruses inactivation rate > 99.9% to reduce the infection rate of the vaccination staff; can reach class 100000 cleanliness after continuously operating for 1 hour; and release healthy negative ions, providing clean air for users to experience forest air quality. Applicable for schools, community hospitals, etc.



Triple Ultra-Strong Air Purification



Plasma Purification

When ionized by high positive and negative voltage, the air can produce a large number of positive and negative ions which will then neutralize with each other, releasing a burst of energy and killing the surrounding bacteria and viruses in an instant.



Ultraviolet PLUS Titanium Dioxide Photocatalyst Purification

The titanium dioxide photocatalyst will have photo-catalytic reaction under the bactericidal ultraviolet light emitted by the 254nm-wavelength dual UV lamps, producing highly oxidizing free hydroxyl groups and active oxygen to have the bacteria, germs, viruses and mold oxidized and decomposed.



Nano-Silver Ion Filtration Layer Purification

Nano-silver ions have broad-spectrum strong bactericidal and antibacterial properties as well as strong permeability and can kill the bacteria and viruses on the filter surface in a few minutes.

Two kinds of filters can reach class 100000 cleanliness after operating for 1 hour

Professional efficient filtration module:
Composed of front filter, pre-filter and high-efficiency HEPA filter screen; can realize a PM2.5 removal rate of > 99.9% after operating for 1 hour.

Honeycomb type activated carbon absorbing mesh:
Adopts coconut shell-based activated carbon, which has an absorption area 65 times larger than that of an ordinary one, to absorb odors, and a professional cold catalyst to catalyze and decompose formaldehyde; can achieve a formaldehyde removal rate of > 95% after operating for 1 hour.

Fresh Air

Negative-ion generator can release negative ions with concentration of over 3 million pcs/cm³ so that the user can enjoy clean air like immersing oneself in a forest.



Friendly Design

- Automatic monitoring of air quality:**
Professional air quality monitoring module to display the air quality with light.
- Freely optional intelligent air speed control and manual control:**
Unique intelligent air speed function; can make adjustment automatically according to the air quality in position 1-5; also enables manual mode for position selection.
- Filter/UV light replacement reminder:**
Giving sound and light warning to remind the operators when service life of the filter module and UV light becomes no more than 10%; after replacement, the service life can be reset.
- Automatic quiet mode switching function:**
Professional photosensitive probe; can automatically switch to quiet mode when the light becomes dark, caring for the users' sleep quality.
- Timed shutdown function:**
Timed shutdown can be set to guarantee using security and extend the service life.
- Fault warning function:**
Gives sound and light alarm when the fan or the UV lamp is in fault.

Model	Voltage (V)	Power (W)	External Dimensions (W*D*H mm)	Net weight (Kg)	Noise level dB(A)	Applicable volume (m ³)	Negative ion concentration	Clean class	Ultraviolet lamp life (h)
YKJX-Y500	220/50	100	439*229*755	13	≤55	≤60	3*10 ⁶	100000	6000
Disinfection effects	When operating for 90min, the killing rate of staphylococcus alba is > 99.9%. After operating for 120min, the average extinction rate of natural bacteria and viruses is > 95.4%								

Wall Mounted Air Purification Sterilizer

Scope of Application

Community service centers, hospitals, clinics and schools etc.



YKJX-B400

Product Advantages

UV Lamp & Filter Replacement Reminder

When the service life of the UV lamp and filter is nearing its usage, a notice for replacement will be sent in a timely manner.

Powerful Disinfection

Equipped with high-power ultraviolet lamp, the bacteria killing rate is $\geq 99.9\%$

Ultra-low Noise

Manufactured with a DC cross-flow fan with a comfortable circulating wind, noise level ≤ 55 dB (A).

Air Purification Sterilizer







Strong UV Disinfection

Special high-power 254nm wavelength UV lamp releases a large amount of sterilizing ultraviolet rays to efficiently kill surrounding bacteria.

Negative Ion Air Purification

It can release more than 3 million healthy negative ions, increase the "vitamins" in the air and improve the comfort of the ambient air.

Ergonomic Design

-  **Fresh air**
Negative-ion generator can release negative ions with concentration of over 3 million pcs/cm³ so that the user can enjoy clean air like immersing oneself in a forest.
-  **Filter/UV light replacement reminder**
Gives sound and light warnings to remind the operators when service life of the filter module and UV light becomes zero; after replacement, the service life can be reset.
-  **Intelligent or manual mode for air speed control**
Unique intelligent air speed function enables adjustments automatically according to the air quality in positions 1-3 and manual mode for position selection is available.
-  **Display of remaining sterilization time**
The default time of sterilization is 120 minutes, from the time the device is started, with an intuitive countdown display.
-  **Automatic monitoring of air quality**
Professional air quality monitoring module to display the air quality with light circle.
-  **Timed shutdown function**
Timed shutdown can be set to guarantee user security and extend the service life.
-  **Night mode**
After turning on the night mode, the screen turns dark after a 3 second delay followed by the sterilizer switching to night mode.

Specifications

Model	Power Supply (V/Hz)	Power (W)	Exterior Dimension (L*H*D mm)	Packing Dimension (L*H*D mm)	Net Weight (Kg)	Noise dB(A)	Applicable Volume (m ³)	Negative Ion Concentration	UV Lamp Life (h)
YKJX-B400	220/50/60	113	900*380*160	1086*540*245	16	≤ 55	50	$3*10^6$	≤ 9000

Disinfection Effects

When operating for 60 minutes, the killing rate of staphylococcus alba is $\geq 99.9\%$. After operating for 120 minutes, the average extinction rate of natural bacteria and viruses is $\geq 90\%$

Medical Infrared Thermometer Rapid Induction and Accurate Measurement



AET-R1B1

Product Advantages

- Highly sensitive infrared probe
- Noncontact measurement
- 1 second measurement

Product Features

- **LED Digital Display**
The reading in the black display box is clear and easy to obtain the temperature value.
- **One Machine Multi-purpose**
The human body/environment mode is automatically switched which can measure the forehead and the ambient temperature giving more comprehensive care.
- **1 Second Measurement**
High sensitive infrared temperature measurement, the temperature value can be measured in one second. It is suitable for multi person temperature measurement or multiple temperature measurement comparison.
- **Ergonomic Design Comfortable to Hold**
With comfortable hand grip, it is easy and solid to hold.



measure forehead temperature



measure environmental temperature

Medical Infrared Thermometer



Led Display



Measure in 1s



°C/°F Switch



Intelligent Accurate



Automatic Shutdown



One Button Measurement



Memory Storage



Replaceable Battery



Forehead Measurement



Personnel Fever Alert

Specifications

Model	AET-R1B1
Product Size (mm)	144*101*26
Product Weight (g)	88 (exclude battery)
Gross weight (Kg)	6.6
Memory (groups)	32
Resolution (°C)	0.1
Measurement range (°C)	32.0-42.2
Accuracy (°C)	±0.2 (35.0-42.0) ±0.3 (32.0-34.9) / (42.1-42.2)
Power supply	2*AAA (DC 3V)
Automatic power-off (s)	60
Box size (mm)	175*120*50
Carton size (mm)	380*370*375
Carton (pcs)	42
Cubic meter (m³)	0.05

Product appearance and specifications are subject to change without notice

UFR106 Infrared Thermometer



UFR106

Product Features



• 1 second measurement



• Green Backlight



• 20 sets memory of measurement values



• Measuring distance 1-3cm



• °C/°F switch

Specifications

Model	UFR106
Measurement method	Non-contact
Measurement range	32.0°C-43.0°C (89.6°F-109.4°F)
Accuracy	±0.2°C/±0.4°F. (within 36°C-39°C/96.8°F-102.2°F)
Display resolution	0.1°C/0.1°F
Memory function	20 sets memory of measurement values
Power source	2pcs AAA alkaline battery
Main unit weight	Approx. 75g (batteries not included)
Main unit size (L*W*H) (mm)	151 * 53 * 41
Box size (mm)	93*53*176
Carton size (mm)	392*290*376
Carton (pcs)	40
Cubic meter (Kg)	6.5
Gross weight (Kg)	5.9

Product appearance and specifications are subject to change without notice

Blood Pressure Monitor



BSX583

Product Features

- Large Display
- 2*99 Memory Storage
- Micro-USB Power source
- WHO Standards

Product Features

- Double users: 2x90 groups
- Average function: Last 3 groups average measuring value
- WHO function
- Arrhythmia checking: Monitor heart rate while measuring the blood pressure.
- Material: ABS+LCD display
- Yellow Backlight



U80H

Product Features

- Memory: 2x120 groups (double users)
- Average function: Last 3 groups average measuring value
- WHO function
- Arrhythmia checking: Monitor heart rate while measuring the blood pressure.
- Material: ABS+LCD display



B15

Blood Pressure Monitor

Specifications

Model	BSX583	U80H	B15
Product size (L*W*H) (mm)	132*112*71	103*103*65mm	140*120*67mm
Product weight (g)	410 (battery included)	230	292.5
Memory (groups)	2*99	2*90	2*120
Resolution	Pressure: ±3 mmHg (±0.4kPa); Pulse: ±5%	/	/
Measurement range	0-290mmHg [0-38.66kPa]; Pulse: 40-180 beats/min	0-299 mmHg [0-37.30kPa] Pulse: 40-199 beats/min	280mmHg [0-37.30kPa] Pulse: 40-199 beats/min
Accuracy	Pressure: ±3mmHg (±0.4kPa); Pulse: ±5%	Pressure: ±3mmHg [0.4kPa] Pulse: ±5% of the reading	Pressure: ±3mmHg [0.4kPa] Pulse: ±5% of the reading
Power supply	4*AA battery (DC 6V)	4*AAA batteries, 1.5 V AC adapter Input: 100-240V AC 50/60Hz Output: 6V DC 1A	4*AA batteries, 1.5 V AC adapter Input: 100-240V AC 50/60Hz Output: 5V DC 1A
Automatic power-off (s)	30	180	60
Box size (mm)	130*95*174	165*116*86	133*95*160
Carton size (mm)	495*277*365	433*335*238	495*340*420
Carton (pcs)	20	20	30
Gross weight (Kg)	10.56±1	9.5	16.34

Product appearance and specifications are subject to change without notice

High Concentration Oxygen Generator



CP303



CP502



CP801



CP101

Product Features

- High quality compressor: low noise level, low power consumption, and long service life
- High quality molecular sieve, durable and efficient
- High concentration oxygen generation, oxygen concentration above 90%
- Intelligent timing, set oxygen absorption time according to requirement
- Self-developed solenoid valve, high-performance, stable, and durable
- High quality technology and master designed circuit board
- Dow Corning material silicone tube, safe and odorless

Specifications

Model	CP303	CP502	CP801	CP101
Flow(L/min)	0.5-3	0-5	0-8	0-10
Purity	0-3L/min, 93±3%	0-5L/min, 93±3%	0-8L/min, 93±3%	0-10L/min, 93±3%
Noise (dB(A))	≤45	≤50	≤53	≤55
Voltage Frequency (V/Hz)	220/50	220/50	220/50	220/50
Power Consumption (VA)	210	370	550	700
Dimension (mm)	362*248*406	400*300*540	400*300*540	400*300*540
Weight (Kg)	9.3	14.5	19.5	20.5
Display Mode	LED	LED	LED	LED

Product appearance and specifications are subject to change without notice

Models Line-up

Cryo Freezer **-86°C ULT Freezer**

DW-130W200 DW-130W200
 DW-66L148S DW-66L148T DW-66L178S DW-66L178T DW-66L228S DW-66L228T DW-66L298S DW-66L298T DW-66L338S DW-66L338T DW-66L408S DW-66L408T
 DW-66L148S DW-66L148T DW-66L178S DW-66L178T DW-66L228S DW-66L228T DW-66L298S DW-66L298T DW-66L338S DW-66L338T DW-66L408S DW-66L408T

ULT Water Cooling **-60°C Freezer**

DW-66L178S DW-66L178T DW-66L228S DW-66L228T DW-66L298S DW-66L298T DW-66L338S DW-66L338T DW-66W100J DW-66W100J DW-66W120J DW-66W120J
 DW-66L178S DW-66L178T DW-66L228S DW-66L228T DW-66L298S DW-66L298T DW-66L338S DW-66L338T DW-66W100J DW-66W100J DW-66W120J DW-66W120J
 DW-66L178S DW-66L178T DW-66L228S DW-66L228T DW-66L298S DW-66L298T DW-66L338S DW-66L338T DW-66W100J DW-66W100J DW-66W120J DW-66W120J

Energy Saving "J" Touch Series **-40°C Biomedical Freezer**

DW-66L178S DW-66L178T DW-66L228S DW-66L228T
 DW-66L178S DW-66L178T DW-66L228S DW-66L228T DW-66L298S DW-66L298T DW-66L338S DW-66L338T DW-66W100J DW-66W100J DW-66W120J DW-66W120J

-30°C Biomedical Freezer **-25°C Biomedical Freezer** **Combined Refrigerator and Freezer**

DW-50L120F DW-50L278 DW-50L308 DW-50L318 DW-50L328 DW-50L338 DW-50L348 DW-50L358 DW-50L368 DW-50L378 DW-50L388 DW-50L398
 DW-25L120 DW-25L120 DW-25L120
 HXC-282 HXC-282A HXC-282B

Pharmacy Refrigerator

HYC-1098 HXC-1098T HXC-1098F HXC-1098TF HXC-1098S HXC-1098T HXC-1098F HXC-1098TF HXC-1098R

Pharmacy Refrigerator

HXR-111 HXR-111 HXR-111 HXR-111 HXR-111 HXR-111 HXR-111 HXR-111 HXR-111 HXR-111 HXR-111 HXR-111
 HXR-111 HXR-111 HXR-111 HXR-111 HXR-111 HXR-111 HXR-111 HXR-111 HXR-111 HXR-111 HXR-111 HXR-111

Models Line-up

Spark Free Freezer/Refrigerator **Laboratory Refrigerator** **Smart Vaccine Refrigerator** **Vaccine & Icepack Freezer** **Solar Direct Drive Combined Refrigerator/Freezer**

DW-23L DW-23L HLR-108SFFL HLR-108SFFL HLR-108SFFL HLR-108SFFL HLR-108SFFL HLR-108SFFL HLR-108SFFL HLR-108SFFL HLR-108SFFL HLR-108SFFL
 HXC-428TR HXC-629TR HXC-1098TR HXC-149R HXC-429R HXC-629R HXC-149 HXC-429 HXC-629 HXC-1098 HXC-149T HXC-429T HXC-629T HXC-1098T HXC-106 HXC-138 HXC-158

Ice-lined Refrigerator

HXC-40 HXC-110 HXC-112 HXC-40 HXC-120 HXC-240 HXC-40 HXC-240 HXC-40 HXC-80 HXC-180 HXC-240

Blood Bank Refrigerator

HXC-428TR HXC-629TR HXC-1098TR HXC-149R HXC-429R HXC-629R HXC-149 HXC-429 HXC-629 HXC-1098 HXC-149T HXC-429T HXC-629T HXC-1098T HXC-106 HXC-138 HXC-158

Transport Cooler **Clean Bench**

HXC-608 HXC-1508 HXC-138B HXC-238B HXC-608B HXC-1508B HZY-6282A HZY-132132A HZY-8B HZY-108(P20) HZY-28B HCB-900V HCB-1600H HCB-1500V HCB-1200H

Biological Safety Cabinet

HRC-182 HRC-182 HRC-182 HRC-182-D HRC-182-S HRC-182 HRC-182 HRC-182 HRC-182 HRC-182-K HRC-182-K HRC-182-K

Liquid Nitrogen Container **CO₂ Incubator** **High-pressure Steam Sterilizer** **Constant Climate Chamber** **Air Purification Sterilizer**

HCP-60/168/238 HRLM-90 HHS-236 HHS-506 HHS-936 YLX-900 YLX-1800

Portable Oxygen Concentrator **Thermometer** **Blood Pressure Monitor** **Consumables** **Walk-in Cold Room**

CP30S CP30E CP30A CP10L AET-R1BL UFR106 BSC3S U30H B13 YLX-900 YLX-1800